

Service Manual



AWG410, AWG420 & AWG430 200 MS/s Arbitrary Waveform Generator

070-A811-52

Warning

The servicing instructions are for use by qualified personnel only. To avoid personal injury, do not perform any servicing unless you are qualified to do so. Refer to all safety summaries prior to performing service.

www.tektronix.com

Copyright © Tektronix Japan, Ltd. All rights reserved.

Copyright © Tektronix, Inc. All rights reserved.

Tektronix products are covered by U.S. and foreign patents, issued and pending. Information in this publication supercedes that in all previously published material. Specifications and price change privileges reserved.

Tektronix, Inc., P.O. Box 500, Beaverton, OR 97077

TEKTRONIX and TEK are registered trademarks of Tektronix, Inc.

WARRANTY

Tektronix warrants that the products that it manufactures and sells will be free from defects in materials and workmanship for a period of one (1) year from the date of shipment. If a product proves defective during this warranty period, Tektronix, at its option, either will repair the defective product without charge for parts and labor, or will provide a replacement in exchange for the defective product.

In order to obtain service under this warranty, Customer must notify Tektronix of the defect before the expiration of the warranty period and make suitable arrangements for the performance of service. Customer shall be responsible for packaging and shipping the defective product to the service center designated by Tektronix, with shipping charges prepaid. Tektronix shall pay for the return of the product to Customer if the shipment is to a location within the country in which the Tektronix service center is located. Customer shall be responsible for paying all shipping charges, duties, taxes, and any other charges for products returned to any other locations.

This warranty shall not apply to any defect, failure or damage caused by improper use or improper or inadequate maintenance and care. Tektronix shall not be obligated to furnish service under this warranty a) to repair damage resulting from attempts by personnel other than Tektronix representatives to install, repair or service the product; b) to repair damage resulting from improper use or connection to incompatible equipment; c) to repair any damage or malfunction caused by the use of non-Tektronix supplies; or d) to service a product that has been modified or integrated with other products when the effect of such modification or integration increases the time or difficulty of servicing the product.

THIS WARRANTY IS GIVEN BY TEKTRONIX IN LIEU OF ANY OTHER WARRANTIES, EXPRESS OR IMPLIED. TEKTRONIX AND ITS VENDORS DISCLAIM ANY IMPLIED WARRANTIES OF MERCHANTABILITY OR FITNESS FOR A PARTICULAR PURPOSE. TEKTRONIX' RESPONSIBILITY TO REPAIR OR REPLACE DEFECTIVE PRODUCTS IS THE SOLE AND EXCLUSIVE REMEDY PROVIDED TO THE CUSTOMER FOR BREACH OF THIS WARRANTY. TEKTRONIX AND ITS VENDORS WILL NOT BE LIABLE FOR ANY INDIRECT, SPECIAL, INCIDENTAL, OR CONSEQUENTIAL DAMAGES IRRESPECTIVE OF WHETHER TEKTRONIX OR THE VENDOR HAS ADVANCE NOTICE OF THE POSSIBILITY OF SUCH DAMAGES.

Table of Contents

| | |
|---|-------------|
| General Safety Summary | xi |
| Service Safety Summary | xiii |
| Preface | xv |
| Manual Structure | xv |
| Manual Conventions | xvi |
| Finding Other Information | xvi |
| Contacting Tektronix | xvii |
| Introduction | xix |
| Performance Verification Procedures | xix |
| Strategy for Servicing | xix |
| Tektronix Service Offerings | xx |

Specifications

| | |
|---------------------------------------|------------|
| Product Overview | 1-1 |
| Product Description | 1-1 |
| Specifications | 1-3 |
| Electrical Specification | 1-4 |
| Certification and Compliances | 1-20 |

Operating Information

| | |
|---------------------------------------|-------------|
| Preparation for Use | 2-1 |
| Supplying Operating Power | 2-1 |
| Operating Environment | 2-3 |
| Installation | 2-4 |
| Repackaging for Shipment | 2-10 |
| Applying and Interrupting Power | 2-11 |
| Operating Basics | 2-13 |
| Controls and Connectors | 2-13 |
| Menu Operations | 2-18 |
| Shortcut Controls | 2-28 |
| File management | 2-29 |
| Double Windows | 2-36 |
| Quick View | 2-38 |
| Setup Overview | 2-40 |

Theory of Operation

| | |
|------------------------------------|------------|
| Theory of Operation | 3-1 |
| Signal Output Process | 3-7 |

Performance Verification

| | |
|-------------------------|-----|
| Conventions | 4-1 |
| Self Tests | 4-3 |
| Performance Tests | 4-7 |

| | |
|--|------|
| AWG400-Series Test Record | 4-13 |
| Operating Mode Tests | 4-19 |
| Internal Clock Frequency Tests | 4-35 |
| Amplitude and Offset Accuracy Tests (Normal Out) | 4-37 |
| Amplitude, Offset Accuracy and Rise Time Tests (Direct DA Out) | 4-46 |
| Step Response Tests (normal out) | 4-54 |
| Internal Trigger Tests | 4-60 |
| Trigger Input Tests | 4-62 |
| Event Input and Enhanced Mode Tests | 4-67 |
| 10 MHz Reference Input Tests | 4-74 |
| Master Clock Input Tests | 4-76 |
| ADD Input Tests | 4-78 |
| Marker Output Tests | 4-81 |
| Channel Skew Tests (AWG420 and AWG430 only) | 4-84 |
| Master Clock Output Tests | 4-87 |
| 10 MHz Reference Output Tests | 4-89 |
| Digital Data Output Tests (Option 03 Only) | 4-91 |

Adjustment Procedures

| | |
|--|------------|
| Overview | 5-1 |
| Purpose | 5-1 |
| Before Adjustments | 5-3 |
| Providing Access | 5-3 |
| Cooling | 5-4 |
| Performance Check/Adjustment Files | 5-6 |
| Adjustment Instructions | 5-7 |

Maintenance

| | |
|--|-------------|
| Maintenance | 6-1 |
| Related Maintenance Procedures | 6-1 |
| Preparation | 6-2 |
| Inspection and Cleaning | 6-4 |
| Removal and Installation Procedures | 6-9 |
| Preparation for Use | 6-9 |
| Access Procedure | 6-16 |
| Procedures for External Modules | 6-17 |
| Procedures for Internal Modules (1) | 6-30 |
| Procedures for Internal Modules (2) | 6-44 |
| Troubleshooting | 6-51 |
| Diagnostics | 6-51 |
| Messages and Codes | 6-59 |
| Command Errors | 6-60 |
| Execution Errors | 6-62 |
| Device Specific Errors | 6-64 |
| Query Errors | 6-65 |
| Power-On Events | 6-65 |
| User Request Events | 6-65 |
| Request Control Events | 6-66 |
| Operation Complete Events | 6-66 |
| Device Errors | 6-67 |

Options and Accessories

| | |
|--------------------------------------|------------|
| Options and Accessories | 7-1 |
| Power Cord Options | 7-1 |
| Options | 7-2 |
| Accessories | 7-3 |

Replaceable Electrical Parts

| | |
|-----------------------------|-----|
| Electrical Parts List | 8-1 |
|-----------------------------|-----|

Diagrams

| | |
|----------------|-----|
| Diagrams | 9-1 |
|----------------|-----|

Replaceable Mechanical Parts

| | |
|--|------|
| Parts Ordering Information | 10-1 |
| Using the Replaceable Parts List | 10-2 |

List of Figures

| | |
|--|------|
| Figure 1–1: Connection method for Digital Data Out | 1–12 |
| Figure 1–2: Pin Assignment of Digital Data Out | 1–12 |
| Figure 1–3: Signal timing | 1–16 |
| Figure 1–4: Dimensions | 1–19 |
| | |
| Figure 2–1: Rear panel power switch, fuse holder, and power connector | 2–7 |
| Figure 2–2: Location of the ON/STBY switch | 2–8 |
| Figure 2–3: Front panel controls | 2–14 |
| Figure 2–4: Front panel keypad area | 2–15 |
| Figure 2–5: Front panel keypad area | 2–16 |
| Figure 2–6: Rear panel signal and power connectors | 2–17 |
| Figure 2–7: Menu buttons, bezel menu buttons, and the CLEAR MENU button | 2–18 |
| Figure 2–8: Bottom and side menus | 2–19 |
| Figure 2–9: Pop-up menu example | 2–20 |
| Figure 2–10: Dialog box example | 2–21 |
| Figure 2–11: Screen menu example | 2–22 |
| Figure 2–12: Knob icon displayed in Status Display area | 2–23 |
| Figure 2–13: Keypad buttons | 2–24 |
| Figure 2–14: Three types of Input text dialog boxes | 2–25 |
| Figure 2–15: Input Filename dialog box | 2–27 |
| Figure 2–16: Shortcut controls | 2–28 |
| Figure 2–17: Files and directories with read only attribute | 2–33 |
| Figure 2–18: Input Filename dialog box | 2–34 |
| Figure 2–19: Double Windows | 2–36 |
| Figure 2–20: Overwrite confirmation | 2–38 |
| Figure 2–21: File list window examples in which Quick View is available | 2–39 |
| Figure 2–22: Viewing a file by Quick View function | 2–39 |
| Figure 2–23: Main Setup screen (AWG430) | 2–40 |
| Figure 2–24: Setup Waveform/Sequence menu | 2–42 |
| Figure 2–25: Viewing a file in the Setup screen | 2–43 |
| | |
| Figure 3–1: AWG400-Series block diagram | 3–2 |
| Figure 3–2: Clock oscillator configuration | 3–3 |
| Figure 3–3: Relationship between memory address control and waveform memory | 3–5 |

| | |
|--|-------------|
| Figure 4–1: Diagnostic menu | 4–4 |
| Figure 4–2: Calibration result message box | 4–5 |
| Figure 4–3: EVENT IN connector pins and signals and ground closure connector | 4–9 |
| Figure 4–4: P4116 Pod Output pins and signals | 4–9 |
| Figure 4–5: Loading file; selecting storage drive | 4–10 |
| Figure 4–6: Continuous mode initial test hookup (Instrument other than option 05) | 4–19 |
| Figure 4–7: Continuous mode initial test hookup (Instrument with option 05) | 4–21 |
| Figure 4–8: Triggered mode initial test hookup (Instrument other than option 05) | 4–23 |
| Figure 4–9: Relationship between trigger signal and waveform output (Instrument other than option 05) | 4–25 |
| Figure 4–10: Triggered mode initial test hookup (Instrument with option 05) | 4–26 |
| Figure 4–11: Relationship between trigger signal and waveform output (Instrument with option 05) | 4–28 |
| Figure 4–12: Relationship between gate signal and waveform output (Instrument other than option 05) | 4–30 |
| Figure 4–13: Relationship between gate signal and waveform output (Instrument with option 05) | 4–33 |
| Figure 4–14: Clock frequency and 10 MHz reference input initial test hookup | 4–35 |
| Figure 4–15: Amplitude accuracy initial test hookup | 4–37 |
| Figure 4–16: Amplitude accuracy initial test hookup | 4–40 |
| Figure 4–17: Direct DA output amplitude accuracy initial test hookup | 4–46 |
| Figure 4–18: Direct DA output amplitude accuracy initial test hookup | 4–48 |
| Figure 4–19: Direct DA output pulse rise time initial test hookup ... | 4–50 |
| Figure 4–20: Direct DA output pulse rise time initial test hookup ... | 4–52 |
| Figure 4–21: Step response initial test hookup | 4–54 |
| Figure 4–22: Step response initial test hookup | 4–57 |
| Figure 4–23: Internal trigger initial test hookup | 4–60 |
| Figure 4–24: Trigger input initial test hookup | 4–62 |
| Figure 4–25: Trigger Signal (+5V check1) | 4–64 |
| Figure 4–26: Trigger Signal (+5V check2) | 4–65 |
| Figure 4–27: Trigger Signal (–5 V check1) | 4–65 |
| Figure 4–28: Trigger Signal (–5 V check2) | 4–66 |

| | |
|---|------|
| Figure 4–29: Event input and enhanced mode initial test hookup . . . | 4–67 |
| Figure 4–30: Waveform while all ground disclosure switches are open | 4–69 |
| Figure 4–31: Waveform output when the SW1 is closed | 4–69 |
| Figure 4–32: Waveform output when SW2 is closed | 4–70 |
| Figure 4–33: Waveform output when the SW3 is closed | 4–71 |
| Figure 4–34: Waveform output when SW4 is closed | 4–71 |
| Figure 4–35: Initial waveform output | 4–72 |
| Figure 4–36: DC waveform output when the SW5 is closed | 4–73 |
| Figure 4–37: 10 MHz reference input initial test hookup | 4–74 |
| Figure 4–38: Master Clock input initial test hookup | 4–76 |
| Figure 4–39: ADD IN input initial test hookup | 4–78 |
| Figure 4–40: Marker output initial test hookup | 4–81 |
| Figure 4–41: Marker output waveform | 4–83 |
| Figure 4–42: Channel skew test hookup | 4–84 |
| Figure 4–43: Master Clock output initial test hookup | 4–87 |
| Figure 4–44: 10MHz Reference output initial test hookup | 4–89 |
| Figure 4–45: Digital data output level initial test hookup | 4–91 |
| Figure 4–46: P4116 Output Connector | 4–92 |
| Figure 4–47: Clock output and data output | 4–94 |
| | |
| Figure 5–1: Cooling the waveform generator during adjustment procedures | 5–4 |
| Figure 5–2: Accessing the service switch | 5–5 |
| Figure 5–3: Adjustment location for the power supply unit | 5–8 |
| Figure 5–4: Hookup for the reference clock frequency adjustment . . | 5–9 |
| Figure 5–5: Continuous mode initial test hookup (Instrument with option 05) | 5–11 |
| Figure 5–6: Adjustment location for the DAC output waveform | 5–13 |
| Figure 5–7: Channel skew test hookup | 5–14 |
| Figure 5–8: Channel skew test hookup for CH2 (1) | 5–17 |
| Figure 5–9: Channel skew test hookup for CH2 (2) | 5–17 |
| Figure 5–10: BitWeight table | 5–19 |
| Figure 5–11: Channel skew test hookup for CH3 | 5–20 |
| | |
| Figure 6–1: Instrument orientation | 6–11 |
| Figure 6–2: External modules | 6–12 |
| Figure 6–3: Internal modules (1) | 6–13 |
| Figure 6–4: Internal modules(1) | 6–14 |
| Figure 6–5: Internal modules(2) | 6–15 |

| | |
|---|-------|
| Figure 6-6: Knob removal | 6-18 |
| Figure 6-7: Line fuse and line cord removal | 6-19 |
| Figure 6-8: Cabinet removal | 6-22 |
| Figure 6-9: Trim ring and menu buttons removal | 6-23 |
| Figure 6-10: A20 Front-Panel assembly removal | 6-25 |
| Figure 6-11: Disassembly of Front-Panel assembly | 6-26 |
| Figure 6-12: Output assembly removal | 6-27 |
| Figure 6-13: Cabinet modules removal | 6-29 |
| Figure 6-14: Fan removal | 6-31 |
| Figure 6-15: Floppy disk drive removal | 6-32 |
| Figure 6-16: Display assembly removal | 6-33 |
| Figure 6-17: Power supply module removal | 6-35 |
| Figure 6-18: A10 Connector board removal | 6-37 |
| Figure 6-19: CPU unit removal | 6-39 |
| Figure 6-20: CPU, A40 PCI Interface, and GPIB boards removal .. | 6-40 |
| Figure 6-21: Hard disk and flash disk removal | 6-41 |
| Figure 6-22: Rear Chassis removal | 6-43 |
| Figure 6-23: A80, A70/A72, A52, A50 Boards removal | 6-45 |
| Figure 6-24: A60 Memory board removal | 6-46 |
| Figure 6-25: Primary troubleshooting procedure | 6-52 |
| Figure 6-26: Troubleshooting procedure 1 — Power Supply module | 6-53 |
| Figure 6-27: Power Supply connectors | 6-54 |
| Figure 6-28: Troubleshooting procedure 2 — CPU or Front Panel module | 6-55 |
| Figure 6-29: Troubleshooting procedure 3 — LCD module | 6-56 |
| Figure 6-30: A10 Connector board | 6-57 |
| Figure 6-31: Troubleshooting procedure 4 — Module isolation | 6-58 |
| | |
| Figure 10-1: Front and Display unit | 10-5 |
| Figure 10-2: Front panel | 10-7 |
| Figure 10-3: Front Output unit | 10-9 |
| Figure 10-4: Chassis | 10-11 |
| Figure 10-5: CPU unit | 10-13 |
| Figure 10-6: Board A50, A52, A72, A80 | 10-15 |
| Figure 10-7: Rear Panel | 10-17 |
| Figure 10-8: Cabinet | 10-19 |
| Figure 10-9: Rack mount | 10-21 |
| Figure 10-10: P4116 | 10-22 |

List of Tables

| | |
|---|-------------|
| Table 1–1: AWG400–Series waveform editors | 1–1 |
| Table 1–2: Operation modes | 1–4 |
| Table 1–3: Arbitrary waveforms | 1–4 |
| Table 1–4: Clock generator | 1–5 |
| Table 1–5: Period jitter | 1–5 |
| Table 1–6: Cycle to Cycle jitter | 1–5 |
| Table 1–7: Internal trigger generator | 1–5 |
| Table 1–8: Main output (Specified at the end of BNC cable, Tektronix part number 012–0482–00) | 1–6 |
| Table 1–9: Complementary Normal Out (Specified at the end of BNC cable, Tektronix part number 012–0482–00) | 1–6 |
| Table 1–10: Single Ended Normal Out (Option 05) (Specified at the end of cable, Tektronix part number 012–0482–00) | 1–8 |
| Table 1–11: Direct DA Out (Specified at the end of cable, Tektronix part number 012–0482–00) | 1–10 |
| Table 1–12: Auxiliary Outputs (Specified at the end of cable, Tektronix part number 012–0057–01) | 1–10 |
| Table 1–13: Digital Data Out (Option 03), specified at the P4116 output connector | 1–11 |
| Table 1–14: Pin Assignment of Digital Data Out (P4116 output connector) | 1–12 |
| Table 1–15: Auxiliary Inputs | 1–13 |
| Table 1–16: Function Generator (FG) | 1–14 |
| Table 1–17: Display | 1–16 |
| Table 1–18: Power Supply | 1–16 |
| Table 1–19: Timer | 1–16 |
| Table 1–20: Interface connectors | 1–16 |
| Table 1–21: Installation requirement | 1–18 |
| Table 1–22: Environmental | 1–18 |
| Table 1–23: Mechanical | 1–19 |
| Table 1–24: Certifications and compliances | 1–20 |
| Table 1–25: Installation category and pollution degree descriptions | 1–21 |
| | |
| Table 2–1: Power-cord conductor identification | 2–2 |
| Table 2–2: Power cord identification | 2–2 |
| Table 2–3: Fuse part numbers | 2–5 |
| Table 2–4: Fuse cap part numbers | 2–5 |
| Table 2–5: Side menu elements | 2–20 |

| | |
|--|------|
| Table 2–6: Text input button functions | 2–27 |
| Table 2–7: Shortcut controls | 2–28 |
| Table 2–8: AWG400-Series Arbitrary Waveform Generator file types | 2–29 |
| Table 2–9: Drive and Directory menus | 2–30 |
| Table 2–10: Waveform record length adjustment messages | 2–34 |
| Table 2–11: File operation in double windows | 2–37 |
| Table 2–12: Confirmation selection for copy-all and move-all operations | 2–38 |
| Table 2–13: Setup screen parameter icons | 2–41 |
| Table 2–14: Setup bottom menu buttons | 2–41 |
| Table 2–15: Setup output parameter operations | 2–44 |
| | |
| Table 3–1: Run modes | 3–5 |
| Table 3–2: Editors | 3–8 |
| | |
| Table 4–1: Performance test items | 4–7 |
| Table 4–2: Test equipment | 4–8 |
| Table 4–3: Waveforms and sequences in performance check disk .. | 4–11 |
| Table 4–4: P4116 Output Connector Pin Assignment | 4–92 |
| | |
| Table 5–1: Adjustments required | 5–1 |
| Table 5–2: Adjustments | 5–2 |
| Table 5–3: Test equipment | 5–3 |
| Table 5–4: File list for Performance Check/Adjustment disk | 5–6 |
| Table 6–1: Relative susceptibility to static-discharge damage | 6–3 |
| Table 6–2: External inspection check list | 6–5 |
| Table 6–3: Internal inspection check list | 6–6 |
| Table 6–4: Tools required for module removal | 6–10 |
| Table 6–5: Definition of event codes | 6–59 |
| Table 6–6: Command errors | 6–60 |
| Table 6–7: Execution errors | 6–62 |
| Table 6–8: Device specific errors | 6–64 |
| Table 6–9: Query errors | 6–65 |
| Table 6–10: Power-on events | 6–65 |
| Table 6–11: User request events | 6–65 |
| Table 6–12: Request control events | 6–66 |
| Table 6–13: Operation complete events | 6–66 |
| Table 6–14: Messages and Codes | 6–67 |

| | |
|---|------------|
| Table 7-1: Power cord identification | 7-1 |
| Table 7-2: Standard accessories | 7-3 |
| Table 7-3: Optional accessories | 7-3 |

General Safety Summary

Review the following safety precautions to avoid injury and prevent damage to this product or any products connected to it. To avoid potential hazards, use this product only as specified.

Only qualified personnel should perform service procedures.

To Avoid Fire or Personal Injury

Use Proper Power Cord. Use only the power cord specified for this product and certified for the country of use.

Connect and Disconnect Properly. Do not connect or disconnect probes or test leads while they are connected to a voltage source.

Ground the Product. This product is grounded through the grounding conductor of the power cord. To avoid electric shock, the grounding conductor must be connected to earth ground. Before making connections to the input or output terminals of the product, ensure that the product is properly grounded.

Observe All Terminal Ratings. To avoid fire or shock hazard, observe all ratings and markings on the product. Consult the product manual for further ratings information before making connections to the product.

The common terminal is at ground potential. Do not connect the common terminal to elevated voltages.

Do not apply a potential to any terminal, including the common terminal, that exceeds the maximum rating of that terminal.

Do Not Operate Without Covers. Do not operate this product with covers or panels removed.

Use Proper Fuse. Use only the fuse type and rating specified for this product.

Avoid Exposed Circuitry. Do not touch exposed connections and components when power is present.

Do Not Operate With Suspected Failures. If you suspect there is damage to this product, have it inspected by qualified service personnel.

Do Not Operate in Wet/Damp Conditions.

Do Not Operate in an Explosive Atmosphere.

Keep Product Surfaces Clean and Dry.

Provide Proper Ventilation. Refer to the manual's installation instructions for details on installing the product so it has proper ventilation.

Symbols and Terms

Terms in this Manual. These terms may appear in this manual:



WARNING. *Warning statements identify conditions or practices that could result in injury or loss of life.*



CAUTION. *Caution statements identify conditions or practices that could result in damage to this product or other property.*

Terms on the Product. These terms may appear on the product:

DANGER indicates an injury hazard immediately accessible as you read the marking.

WARNING indicates an injury hazard not immediately accessible as you read the marking.

CAUTION indicates a hazard to property including the product.

Symbols on the Product. The following symbols may appear on the product:



WARNING
High Voltage



Protective Ground
(Earth) Terminal



CAUTION
Refer to Manual



Double
Insulated

Service Safety Summary

Only qualified personnel should perform service procedures. Read this *Service Safety Summary* and the *General Safety Summary* before performing any service procedures.

Do Not Service Alone. Do not perform internal service or adjustments of this product unless another person capable of rendering first aid and resuscitation is present.

Disconnect Power. To avoid electric shock, disconnect the mains power by means of the power cord or, if provided, the power switch.

Use Care When Servicing With Power On. Dangerous voltages or currents may exist in this product. Disconnect power, remove battery (if applicable), and disconnect test leads before removing protective panels, soldering, or replacing components.

To avoid electric shock, do not touch exposed connections.

Calendar (date and time) Backup Battery. This product contains a Lithium:poly-carbon monofluoride battery for calendar backup purposes. This battery is part of the CPU unit and is not replaceable.

Preface

This is the service manual for the AWG400-Series. The manual contains information needed to service the waveform generator to the module level.

Manual Structure

This manual is divided into sections, such as *Specifications* and *Theory of Operation*. Further, some sections are divided into subsections, such as *Product Description* and *Removal and Installation Procedures*.

Sections containing procedures also contain introductions to those procedures. Be sure to read these introductions because they provide information needed to do the service correctly and efficiently. The following contains a brief description of each manual section.

- *Specifications* contains a description of the waveform generator and the characteristics that apply to it.
- *Operating Information* includes general information and operating instructions.
- *Theory of Operation* contains circuit descriptions that support service to the module level.
- *Performance Verification* contains procedures for confirming that the waveform generator functions properly and meets warranted limits.
- *Adjustment Procedures* contains information that you need to manually adjust the waveform generator so that it meets specifications.
- *Maintenance* contains information and procedures for performing preventive and corrective maintenance of the waveform generator. These instructions include cleaning, module removal and installation, and fault isolation to the module.
- *Options* contains information on servicing factory-installed options.
- *Replaceable Electrical Parts* contains a statement referring you to *Replaceable Mechanical Parts*, where both electrical and mechanical modules are listed.
- *Diagrams* contains block diagrams and an interconnection diagram.
- *Replaceable Mechanical Parts* includes a table of all replaceable modules, their descriptions, and their Tektronix part numbers.

Manual Conventions

This manual uses certain conventions that you should become familiar with.

Some sections of the manual contain procedures for you to perform. To keep those instructions clear and consistent, this manual uses the following conventions:

- Names of front panel controls and menus appear in the same case (initial capitals, all uppercase, and so on) in the manual as is used on the waveform generator front panel and menus. Front-panel names are all upper case letters (for example, SETUP, UTILITY, HARDCOPY, and so on).
- Instruction steps are numbered unless there is only one step.

Modules

Throughout this manual, any replaceable component, assembly, or part of the waveform generator is referred to generically as a module. In general, a module is an assembly (like a circuit board), rather than a component (like a resistor or an integrated circuit). Sometimes a single component is a module; for example, the chassis of the waveform generator is a module.

Safety

Symbols and terms related to safety appear in the *Safety Summary* near the beginning of this manual.

Finding Other Information

Other documentation for the AWG400-Series includes:

- The AWG400-Series user manual contains a tutorial to quickly describe how to operate the waveform generator. It also includes an in-depth discussion on how to more completely use the waveform generator features.
- The AWG400-Series programmer manual explains how to use a GPIB interface to remotely control the waveform generator.

Contacting Tektronix

| | |
|--------------------------|---|
| Phone | 1-800-833-9200* |
| Address | Tektronix, Inc. Department or name (if known) 14200 SW Karl Braun Drive P.O. Box 500 Beaverton, OR 97077 USA |
| Web site | www.tektronix.com |
| Sales support | 1-800-833-9200, select option 1* |
| Service support | 1-800-833-9200, select option 2* |
| Technical support | Email: techsupport@tektronix.com 1-800-833-9200, select option 3* 1-503-627-2400 6:00 a.m. – 5:00 p.m. Pacific time |

* **This phone number is toll free in North America. After office hours, please leave a voice mail message.
Outside North America, contact a Tektronix sales office or distributor; see the Tektronix web site for a list of offices.**

Introduction

This manual contains information that is needed to properly service the AWG400-Series Arbitrary Waveform Generators, as well as general information that is critical to safe and effective servicing.

To prevent personal injury or damage to the waveform generator, consider the following before attempting service:

- The procedures in this manual should be performed only by a qualified service person.
- Read the *General Safety Summary* and the *Service Safety Summary*, beginning on page xi.
- Read *Preparation for Use* in *Operating Information*.

When using this manual for servicing, be sure to follow all warnings, cautions, and notes.

Performance Verification Procedures

The performance check described in the *Performance Verification* section should be done every 12 months. In addition, a performance check is recommended after module replacement.

If the waveform generator does not meet performance criteria, repair is necessary.

Strategy for Servicing

Throughout this manual, the term, *module*, refers to any field-replaceable component, assembly, or part of the waveform generator.

This manual contains all the information needed for periodic maintenance of the waveform generator. Further, it contains all information for corrective maintenance down to the module level. To isolate a failure to a module, use the troubleshooting procedures found in the *Maintenance* section. To remove and replace any failed module, follow the instructions in the *Removal and Installation Procedures* subsection. After isolating a faulty module, replace it with a fully-tested module obtained from the factory. The *Replaceable Mechanical Parts* section contains part number and ordering information for all replaceable modules.

Tektronix Service Offerings

Tektronix provides service to cover repair under warranty as well as other services that may provide a cost-effective answer to your service needs.

Whether providing warranty repair service or any of the other services listed below, Tektronix service technicians are well trained to service the waveform generator. They have access to the latest information on improvements to the AWG400-Series as well as new options.

Warranty Repair Service

Tektronix warrants this product for one year from date of purchase. The warranty appears at the front of this manual. Tektronix technicians provide warranty service at most Tektronix service locations. The Tektronix product catalog lists all worldwide service locations.

Self Service

Tektronix supports repair to the module level by providing Module Exchange.

Module Exchange. This service reduces down-time for repair by allowing you to exchange most modules for remanufactured ones. Each module comes with a 90-day service warranty.

For More Information. Contact your local Tektronix service center or sales engineer for more information on any of the repair or adjustment services just described.

Product Overview

Product Description

The AWG400-Series Arbitrary Waveform Generator is a programmable Arbitrary Waveform Generator which has a maximum 200 MS/s, 4 M word per channel waveform memory and 16-bits DAC. Amplitude is programmable up to 2.0 V (Complementary output) or {5 V (Single-Ended output) optional} peak-to-peak into 50 Ω with independent offset control.

The exterior of the AWG400-Series Arbitrary Waveform Generator is similar to the AWG500/AWG600-series product, except that the parameters and operating menus are displayed on an LCD color monitor instead of a monotone CRT (cathode ray tube).

The instrument can be manually controlled from the front panel and remotely programmed via a GPIB (General Purpose Interface Bus) or Network.

The AWG400-Series Arbitrary Waveform Generator GPIB is compatible with other devices that meet IEEE standard 488.2.

The AWG400-Series Arbitrary Waveform Generator allows you to create sine, triangle, square, ramp, and complex waves, as well as direct current and noise signals. It allows you to set waveform attributes, such as frequency, amplitude, and offset.

This instrument contains a hard disk drive, a 3.5-inch floppy disk drive, and an Ethernet interface for storing and recalling waveform data and instrument settings.

Main Features

The AWG400-Series Arbitrary Waveform Generator contains the following main features:

- 200 MS/s sampling rate
- 16-bit DA converter
- 4 M-word waveform memory
- Two arbitrary marker outputs per channel
- Five waveform editors (see Table 1-1)

Table 1-1: AWG400-Series waveform editors

| Editor | Description |
|----------|--|
| Waveform | Creates analog waveform data in graphic or tabular form. |
| Pattern | Creates analog waveform data in timing and table form. |

Table 1-1: AWG400-Series waveform editors (Cont.)

| Editor | Description |
|----------|--|
| Sequence | Creates sequences of waveforms by combining the waveform files created with the Waveform and/or Pattern Editors. |
| Text | Edits plain ASCII-format waveform files. For example, you can use the Text editor to edit ASCII-format waveform files that are read from an external device. |
| Equation | Creates files with equations and compiles them into waveform files. |

Additional Features

The AWG400-Series Arbitrary Waveform Generator provides the following additional features:

- An Ethernet port (100/10 BASE-T Interface) for using the NFS (Network File System) and FTP link for remotely controlling the AWG400-Series. Refer to the Reference: *Ethernet Networking* section in the AWG400-Series User Manual for information.
- A GPIB interface that can be used for remotely controlling the AWG400-Series and for transferring the waveform data from external oscilloscopes. Refer to *Connecting to a GPIB Network of The UTILITY Window* of section 3 Reference on AWG400-Series user manual for information on setting the GPIB parameters.

Refer to the *AWG400-Series* programmer manual for information on the remote control commands.

Refer to the *Reference: Capturing Waveforms* section of the AWG400-Series user manual for transferring waveforms from the external oscilloscopes to the waveform generator.
- A port on the rear panel for connecting a 101- or 106-type keyboard to the AWG400-Series Arbitrary Waveform Generator. You can input values or text with the keyboard instead of using the numeric keypad on the front panel. Refer to the *Reference: External Keyboards* section of the AWG400-Series user manual.
- An internal clock for setting up the current date and time. Refer to *Internal Clock (Date and Time)* in the AWG400-Series user manual. This setup procedure is also described in *Tutorial 1: Instrument Setup*.
- Provides an adjustment for switching the LCD backlight on or off. Refer to the *Reference: Screen Display Enable/Disable* section of the AWG400-Series user manual.

Specifications

This section contains the AWG400-Series Arbitrary Waveform Generator specifications. All specifications are guaranteed unless labeled “typical”. Typical specifications are provided for your convenience but are not guaranteed.

Specifications that are marked with the ✓ symbol in the column Characteristics, are checked in the *Performance Verification* procedures and the page number referenced to the corresponding performance verification procedures can be found in the column PV reference page.

The characteristics in the specifications are listed in tables that are divided into categories. In these tables, the subcategories may also appear in boldface under the column, Characteristics.

Performance Conditions

The performance limits in this specification are valid with these conditions:

- The AWG400-Series Arbitrary Waveform Generator must have been calibrated and adjusted at an ambient temperature between +20° C and +30° C.
- The AWG400-Series Arbitrary Waveform Generator must be in an environment with temperature, altitude, humidity, and vibration within the operating limits described in these specifications.
- The AWG400-Series Arbitrary Waveform Generator must have had a warm-up period of at least 20 minutes.
- The AWG400-Series Arbitrary Waveform Generator must be operating at an ambient temperature between +10° C and +40° C (+50° F and +104° F).

Warranted characteristics are described in terms of quantifiable performance limits which are warranted.

Electrical Specification

Table 1-2: Operation modes

| Characteristics | Description | PV reference page |
|---------------------|--|-------------------|
| ✓ Continuous | Waveform is continuously output in this mode. When a sequence is defined, waveforms are sequentially or repeatedly output in the order defined by the sequence. The extended sequence functions such as trigger input, event jump, and so on are neglected in this mode. | Page 4-19 |
| ✓ Triggered | Waveform is output only once when a trigger event is created. A trigger signal is created by the external trigger input signal, GPIB trigger command, and/or pressing the front-panel FORCE TRIGGER button. The extended sequence functions such as trigger input, event jump, and so on are neglected in this mode. | Page 4-23 |
| ✓ Gated | The waveform is output in the same way as in the continuous mode only when the gate is opened. The gate is opened by the gated signal. Note that the output is made from the top of the first waveform for every gate period. The clock signal continuously outputs from the connector outside the gate period. | Page 4-29 |
| ✓ Enhanced | The waveforms are sequentially or repeatedly output according to the procedures defined in the sequence. All extended functions such as trigger input, event jump, and so on are effective and waveforms are controlled for output by this functions in this mode. | Page 4-67 |

Table 1-3: Arbitrary waveforms

| Characteristics | Description |
|--|---|
| Waveform length | 64 to 4,050,000 points |
| Waveform length (Option 01 16 M memory) | 64 to 16,200,000 points |
| Sequence length | 1 to 8,000 steps (All CH1, CH2 and CH3 operate same sequence.) |
| Sequence repeat counter | 1 to 65,536 and infinite |
| Storage | |
| Hard Disk | Up to 4.0 Gbytes (The available space is 90% of the total disk space.) |
| Flash Disk (Option 10) | 128 Mbytes (This option deletes the hard disk; the available space is 90% of the total flash disk space.) |
| Floppy Disk | 1.44 Mbytes |

Table 1-4: Clock generator

| Characteristics | Description | PV reference page |
|-----------------------------|--|-------------------|
| Sampling frequency | 10.00000 kHz to 200.0000 MHz | |
| Resolution | 7 digits | |
| Internal clock ¹ | | |
| ✓ Accuracy | ±0.0002% 10° C to 40° C (50° F to 104° F), during 1 year after calibration | Page 4-35 |
| Phase noise, Typical | -84 dBc / Hz (at 100 MHz with 10 kHz offset) | |
| Jitter, Typical | | |
| Period | Refer to Table 1-5, Measured by TDS7104 with TDSJIT2 | |
| Cycle to Cycle | Refer to Table 1-6, Measured by TDS7104 with TDSJIT2 | |

¹ The internal reference oscillator is used.

Table 1-5: Period jitter

| Clock Frequency | 200 MS/s | | 100 MS/s | |
|--------------------|----------|-------|----------|-------|
| | StdDev | Pk-Pk | StdDev | Pk-Pk |
| Measurement method | 7 ps | 45 ps | 8 ps | 50 ps |

Table 1-6: Cycle to Cycle jitter

| Clock Frequency | 200 MS/s | | 100 MS/s | |
|--------------------|----------|-------|----------|-------|
| | StdDev | Pk-Pk | StdDev | Pk-Pk |
| Measurement method | 12 ps | 80 ps | 15 ps | 85 ps |

Table 1-7: Internal trigger generator

| Characteristics | Description | PV reference page |
|------------------------------------|--------------------------|-------------------|
| Internal trigger rate ² | | |
| Range | 1.0 µs to 10.0 s | |
| Resolution | 3 digits, 0.1 µs minimum | |
| ✓ Accuracy | ±0.1% | Page 4-62 |

² The internal reference oscillator is used.

Table 1-8: Main output
(Specified at the end of BNC cable, Tektronix part number 012-0482-00)

| Characteristics | Description | PV reference page |
|--|--|-------------------|
| Output connector | BNC connectors | |
| Output signal | | |
| AWG410 (AWG410 Option 05) | Complementary; CH1 and $\overline{\text{CH1}}$ Single-ended: CH1 | |
| AWG420 (AWG420 Option 05) | Complementary; CH1 and $\overline{\text{CH1}}$ Complementary; CH2 and $\overline{\text{CH2}}$ Single-ended: CH1 and CH2 | |
| AWG430 (AWG430 Option 05) | Complementary; CH1 and $\overline{\text{CH1}}$ Complementary; CH2 and $\overline{\text{CH2}}$ Complementary; CH3 and $\overline{\text{CH3}}$ Single-ended: CH1, CH2 and CH3 | |
| DA converter | | |
| Resolution | 16 bits | |
| Differential nonlinearity, Typical | Within ± 3 LSB at 25° C (77° F) | |
| Integral nonlinearity, Typical | Within ± 4 LSB at 25° C (77° F) | |
| Glitch energy, Typical | 50 pV _{-s} , at 1 V _{p-p} 200 MS/s | |
| Output Impedance | 50 Ω | |
| Variable Delay | | Page 4-84 |
| Range | -2.52 ns to +2.52 ns | |
| Resolution | 70 ps | |
| Accuracy | $\leq \pm 70$ ps at 25° C, $\leq \pm 120$ ps from 10° C to 20° C (50° F to 68° F) | |
| Skew time between channels to CH1 | (At variable delay set to 0 ns.) | |
| CH2(AWG420), Typical | $\leq \pm 100$ ps | |
| Ch2 & CH3 (AWG430), Typical | $\leq \pm 100$ ps | |

Table 1-9: Complementary Normal Out
(Specified at the end of BNC cable, Tektronix part number 012-0482-00)

| Characteristics | Description | PV reference page |
|-----------------------|--|-------------------|
| Output voltage | -2.0 V to +2.0 V, into a 50 Ω load | |
| Amplitude | | |
| Range | 20 mV _{p-p} to 2 V _{p-p} , into a 50 Ω load | |
| Resolution | 1 mV | |
| DC accuracy | $\pm(1.5\%$ of amplitude + 2 mV), offset: 0 V | Page 4-37 |

**Table 1-9: Complementary Normal Out
(Specified at the end of BNC cable, Tektronix part number 012-0482-00) (Cont.)**

| Characteristics | Description | PV reference page |
|------------------------|--|-------------------|
| Offset | | |
| Range | -1.00 V to 1.00 V, into a 50 Ω load | |
| Resolution | 1 mV | |
| ✓ Accuracy | $\pm(1\%$ of offset + 10 mV), (at 20 mV amplitude setting, waveform data: 0) | Page 4-43 |
| ✓ Step response | | |
| | (Waveform data: -1 and 1, offset: 0 V, filter: through) | Page 4-54 |
| Rise time | ≤ 4 ns (at 10% to 90% of amplitude) | |
| Fall time | ≤ 4 ns (at 10% to 90% of amplitude) | |
| Aberration | (Measured by TDS784D, Filter: Through) $\pm 10\%$ (amplitude > 1.0 V _{p-p}) $\pm 7\%$ (amplitude ≤ 1.0 V _{p-p}) | |
| Flatness | $\pm 3\%$ (after 50 ns from rise and fall edges) | |
| SFDR, Typical | (Signal Frequency: 1.00 MHz, Amplitude: 1.0 V _{p-p} , Offset: 0 V, Filter: Through, DC to 5 MHz, Measured by WCA 330) ≤ -74 dBc (50 MHz) ≤ -74 dBc (100 MHz) ≤ -62 dBc (150 MHz) | |
| Filter | | |
| Type | Bessel low pass filter (5th order), 1 MHz, 5 MHz, 20 MHz, and 50 MHz | |
| Rise time, Typical | (10% to 90% of amplitude) | |
| 1 MHz | 350 ns | |
| 5 MHz | 70 ns | |
| 20 MHz | 18 ns | |
| 50 MHz | 7 ns | |
| Group Delay, Typical | | |
| 1 MHz | 350 ns | |
| 5 MHz | 70 ns | |
| 20 MHz | 18 ns | |
| 50 MHz | 7 ns | |

**Table 1-9: Complementary Normal Out
(Specified at the end of BNC cable, Tektronix part number 012-0482-00) (Cont.)**

| Characteristics | Description | PV reference page |
|-------------------|--|-------------------|
| Noise | Ch1, Ch2, Ch3 Independently | |
| Level | | |
| Range | -140 dBm/Hz to -95 dBm/Hz | |
| Resolution | 1 dBm/Hz | |
| Accuracy, Typical | | |
| Complementary | ±2.5 dB at (-95 dBm/Hz to -130 dBm/Hz at 10 MHz) +4/-1 dB at (-131 dBm/Hz to -140 dBm/Hz at 10 MHz) | |
| Flatness | ±2.5 dB (1 MHz to 100 MHz, -95 dBm/Hz at 50 MHz) | |
| Type | Gaussian | |
| Connector | Output is from CH1 / CH2 / CH3 analog output connector | |

**Table 1-10: Single Ended Normal Out (Option 05)
(Specified at the end of cable, Tektronix part number 012-0482-00)**

| Characteristics | Description | PV reference page |
|-----------------------|--|-------------------|
| Output Voltage | -5.0 V to +5.0 V into a 50 Ω load | |
| Range | 20 mV _{p-p} to 5 V _{p-p} , into a 50 Ω load | |
| Resolution | 1 mV | |
| ✓ DC Accuracy | ±(1.5% of Amplitude + 2 mV) at offset = 0 V | Page 4-40 |
| Offset | | |
| Range | -2.500 V to 2.500 V into a 50 Ω load | |
| Resolution | 1 mV | |
| ✓ Accuracy | ± (1 % of offset + 10 mV) at 20 mV Amplitude (waveform data : 0) | Page 4-44 |
| Step Response | (Waveform data: -1 and 1, offset: 0 V, Filter: Through) | Page 4-57 |
| Rise time | ≅ 5 ns (at 10% to 90% of amplitude) | |
| Fall time | ≅ 5 ns (at 10% to 90% of amplitude) | |
| Aberration | (Filter Through, Measured by TDS784D) ± 10% (Amplitude > 1.0 V _{p-p}) ± 7% (Amplitude ≅ 1.0 V _{p-p}) | |
| Settling time | ± 3% (After 50 ns from rise/fall edges.) | Page 4-57 |

Table 1-10: Single Ended Normal Out (Option 05)
(Specified at the end of cable, Tektronix part number 012-0482-00) (Cont.)

| Characteristics | Description | PV reference page | | | | | | | | |
|------------------------------------|---|-------------------|--------|-------|-------|--------|-------|--------|------|--|
| SFDR, Typical | (Signal Frequency: 1.00 MHz, Amplitude: 1.0 V _{p-p} , Offset: 0V, Filter: Through, DC to 5 MHz, Measured by WCA 330) ≤ -72 dBc at 50 MHz ≤ -70 dBc at 100 MHz ≤ -60 dBc at 150 MHz | | | | | | | | | |
| Filter Type | Bessel low pass filter (5th order), 1 MHz, 5 MHz, 20 MHz, and 50 MHz | | | | | | | | | |
| Rise time , Typical | (at 10% to 90% of amplitude) <table> <tr> <td>1 MHz</td> <td>350 ns</td> </tr> <tr> <td>5 MHz</td> <td>70 ns</td> </tr> <tr> <td>20 MHz</td> <td>18 ns</td> </tr> <tr> <td>50 MHz</td> <td>7 ns</td> </tr> </table> | 1 MHz | 350 ns | 5 MHz | 70 ns | 20 MHz | 18 ns | 50 MHz | 7 ns | |
| 1 MHz | 350 ns | | | | | | | | | |
| 5 MHz | 70 ns | | | | | | | | | |
| 20 MHz | 18 ns | | | | | | | | | |
| 50 MHz | 7 ns | | | | | | | | | |
| Group Delay , Typical | <table> <tr> <td>1 MHz</td> <td>350 ns</td> </tr> <tr> <td>5 MHz</td> <td>70 ns</td> </tr> <tr> <td>20 MHz</td> <td>18 ns</td> </tr> <tr> <td>50 MHz</td> <td>7 ns</td> </tr> </table> | 1 MHz | 350 ns | 5 MHz | 70 ns | 20 MHz | 18 ns | 50 MHz | 7 ns | |
| 1 MHz | 350 ns | | | | | | | | | |
| 5 MHz | 70 ns | | | | | | | | | |
| 20 MHz | 18 ns | | | | | | | | | |
| 50 MHz | 7 ns | | | | | | | | | |
| Noise Level | Ch1, Ch2, Ch3 Independently | | | | | | | | | |
| Range | -130 dBm/Hz to -95 dBm/Hz | | | | | | | | | |
| Resolution | 1 dB/Hz | | | | | | | | | |
| Accuracy, Typical Complementary | ± 2.5 dB at (-95 dBm/Hz to -120 dBm/Hz at 10 MHz) +4/-1 dB at (-121 dBm/Hz to -130 dBm/Hz at 10 MHz) | | | | | | | | | |
| Flatness | ± 2.5 dB (1 MHz to 100 MHz, -95 dBm/Hz at 50 MHz) | | | | | | | | | |
| Type | Gaussian | | | | | | | | | |
| Connector | Output is from CH1 / CH2 / CH3 analog output connector | | | | | | | | | |

Table 1-11: Direct DA Out
(Specified at the end of cable, Tektronix part number 012-0482-00)

| Characteristics | Description | PV reference page |
|------------------------|--|-------------------|
| Output Voltage | -0.25 V to +0.25 V, into a 50 Ω load | |
| Amplitude | | |
| Range | 20 mV _{p-p} to 0.5 V _{p-p} , into a 50 Ω load | |
| Resolution | 1 mV | |
| DC Accuracy | \pm (1.5% of Amplitude + 2 mV) | |
| Offset | \leq 10 mV (after calibration) | |
| ✓ Step response | (Filter: Through) | Page 4-46 |
| Rise time | \leq 3 ns (at 10% to 90% of amplitude) | |
| Fall time | \leq 3 ns (at 10% to 90% of amplitude) | |

Table 1-12: Auxiliary Outputs
(Specified at the end of cable, Tektronix part number 012-0057-01)

| Characteristics | Description | PV reference page |
|--|---|-------------------|
| Marker | | |
| Number of Markers | | |
| AWG410 | 2 | |
| AWG420 | 4 (2 per channel) | |
| AWG430 | 6 (2 per channel) | |
| Maximum Data Rate | 10 kbps to 200 Mbps | |
| ✓ Level | 74LVC541A Output Driver | Page 4-81 |
| Hi | 2.4 V minimum into a 50 Ω load; 4.8 V minimum into a 1 M Ω load | |
| Lo | 0.1 V maximum into a 50 Ω load; 0.2 V maximum into a 1 M Ω load | |
| Rise/Fall time | 4 ns maximum (at 10% to 90% of amplitude) | |
| Marker Skew, Typical | \leq 100 ps | |
| Skew, Typical | | |
| Between Marker 1 to Marker 2 | \leq 100 ps | |
| Between Analog Output to Marker Output | 4 ns (Complementary Output) 6 ns (Option 05, Single Ended) | |
| Maximum Output Current | \pm 100 mA | |
| Master Clock Out | | Page 4-87 |
| Frequency | 100 MHz to 200 MHz decided by Sampling Frequency | |
| ✓ Amplitude | 1 V _{p-p} into a 50 Ω load \pm 0.3 V | |
| Impedance | 50 Ω | |

**Table 1-12: Auxiliary Outputs
(Specified at the end of cable, Tektronix part number 012-0057-01) (Cont.)**

| Characteristics | Description | PV reference page |
|-----------------------------|--|-------------------|
| Connector | BNC, Rear Panel | |
| 10 MHz Reference Out | | Page 4-89 |
| ✓Amplitude | 1 V _{p-p} minimum into a 50 Ω load 3 V _{p-p} maximum into a 1 MΩ load | |
| Impedance | 50 Ω, AC Coupled | |
| Connector | BNC, Rear Panel | |
| Display Monitor Out | | |
| Format | VGA | |
| Connector | Dsub 9 pin, Rear Panel | |

Table 1-13: Digital Data Out (Option 03), specified at the P4116 output connector

| Characteristics | Description | PV reference page |
|-------------------------------|---|-------------------|
| Output Signals | D0 to D15 (16 bits), Clock (Refer to Figure 1-2 and Table 1-14) | |
| Output Connector | 34-Pin Header | |
| Maximum Data rate | 10 kbps to 100 Mbps | |
| ✓Level | 74LVC541A Output Driver | Page 4-91 |
| Hi | 2.3 V minimum into a 50 Ω load; 4.6 V minimum into a 1 MΩ load | |
| Lo | 0.1 V maximum into a 50 Ω load; 0.2 V maximum into a 1 MΩ load | |
| Rise/Fall time | 3 ns maximum (at 10% to 90% of amplitude) | |
| Skew, Typical | 1 ns | |
| CH1 Marker Output to Clock | 6.5 ns (Refer Figure 1-3, Td3) | |
| Clock to Data | 2.5 ns (Refer Figure 1-3, Td4) | |
| Maximum Output Current | ±70 mA | |

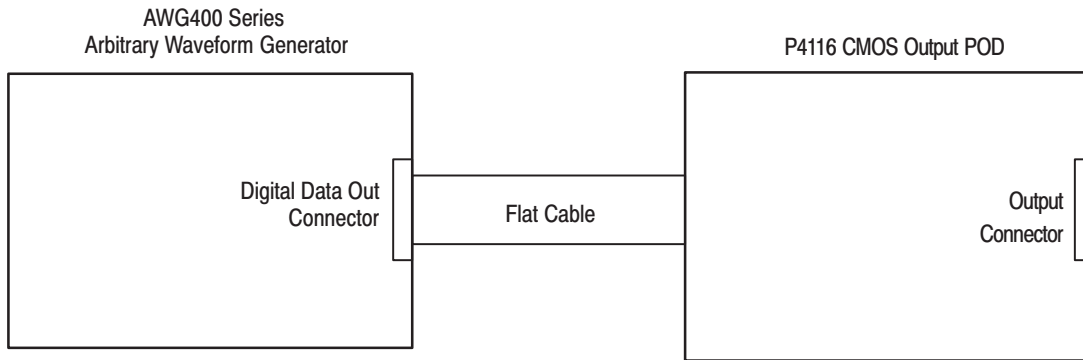

Figure 1-1: Connection method for Digital Data Out

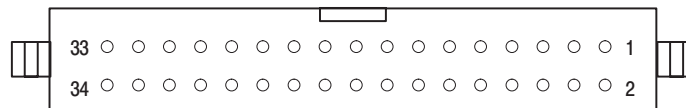

Figure 1-2: Pin Assignment of Digital Data Out

Table 1-14: Pin Assignment of Digital Data Out (P4116 output connector)

| Pin no. | Signal | Pin no. | Signal |
|---------|-----------|---------|--------|
| 1 | CLOCK | 2 | GND |
| 3 | D15 (MSB) | 4 | GND |
| 5 | D14 | 6 | GND |
| 7 | D13 | 8 | GND |
| 9 | D12 | 10 | GND |
| 11 | D11 | 12 | GND |
| 13 | D10 | 14 | GND |
| 15 | D9 | 16 | GND |
| 17 | D8 | 18 | GND |
| 19 | D7 | 20 | GND |
| 21 | D6 | 22 | GND |
| 23 | D5 | 24 | GND |
| 25 | D4 | 26 | GND |
| 27 | D3 | 28 | GND |
| 29 | D2 | 30 | GND |
| 31 | D1 | 32 | GND |
| 33 | D0 (LSB) | 34 | GND |

Note: The pin assignment is common in CH1, CH2, and CH3.

Table 1-15: Auxiliary Inputs

| Characteristics | Description | PV reference page |
|---------------------------------|--|-------------------|
| Trigger In | | |
| Connector | BNC, Rear Panel | |
| Impedance | 1 k Ω or 50 Ω 50 $\Omega \pm 2 \Omega$ 1 k $\Omega \pm 100 \Omega$ | |
| Polarity | POS or NEG | |
| Input Voltage Range | ± 10 V, 1 k Ω selected ± 5 V, 50 Ω selected | |
| ✓ Threshold | | Page 4-62 |
| Level | -5.0 V to 5.0 V | |
| Resolution | 0.1 V | |
| Accuracy | \pm (5% of Level + 0.1 V) | |
| Pulse Width | 10 ns minimum, 0.2 V amplitude | |
| Trigger Dead-time | \leq 65 Clock + 200 ns maximum | |
| Delay to Analog Output, Typical | 50 ns + 1 clock (Refer to Figure 1-3, Td1) | |
| Event In | | |
| Input Signals | 4 Event Bits, Strobe | |
| Number of Event | 4 Bits | |
| Threshold | TTL Level | |
| Pulse Width | \geq 100 ns (Refer to Figure 1-3, Td6) | |
| ✓ Minimum Input | 0 V to +5 V (DC + peak-AC) | Page 4-67 |
| Impedance | 2.2 k Ω , Pull-up to + 5 V | |
| Delay to Analog out | \leq 130 Sequence Clock + 400 ns | |
| Connector | 9 pin, Dsub, Rear Panel | |
| ADD In | | |
| | Ch1/Ch2/Ch3 Independent Input | |
| Input Voltage Range | -1 V to +1 V (DC + peak-AC) | |
| Impedance | 50 Ω | |
| Bandwidth | \geq 50 MHz (-3 dB) at 1 V _{p-p} Input | |
| ✓ Amplitude Accuracy | \pm 5% Note: Output cannot exceed ± 5 V (into 50 Ω) | Page 4-78 |
| Connector | BNC, Rear Panel | |

Table 1-15: Auxiliary Inputs (Cont.)

| Characteristics | Description | PV reference page |
|-----------------------------|---|-------------------|
| 10 MHz Reference In | | |
| Input voltage range | 0.2 V _{p-p} to 3.0 V _{p-p} ±10 V max | |
| Impedance | 50 Ω, AC Coupled | |
| ✓ Frequency Range | 10 MHz ±0.1 MHz | Page 4-74 |
| Connector | BNC, Rear Panel | |
| Master Clock In | | |
| Threshold Voltage | 0.5 V | |
| Impedance | 50 Ω | |
| ✓ Input Sensitive Amplitude | ≥ 0.4 V _{p-p} (Threshold Voltage : 0.5 V _{DC}) | Page 4-76 |
| Minimum Pulse Width | 2 ns | |
| Maximum Input Voltage | ±2 V _{DC} | |
| Frequency Range | DC to 200 MHz | |
| Connector | BNC, Rear Panel | |

Table 1-16: Function Generator (FG)

| Characteristics | Description |
|-----------------------|--|
| Operation Mode | Continuous mode only |
| Waveform Shape | Sine, Triangle, Square, Ramp, Pulse, DC |
| Frequency | 1.000 Hz to 10.00 MHz |
| Amplitude | |
| Range | 0.020 V _{p-p} to 2.000 V _{p-p} , into a 50 Ω load 0.020 V _{p-p} to 5.000 V _{p-p} , into a 50 Ω load (Option 05) |
| Resolution | 1 mV |
| Offset | |
| Range | -1.000 V to +1.000 V, into a 50 Ω load -2.500 V to +2.500 V, into a 50 Ω load (Option 05) |
| Resolution | 1 mV |
| DC Level | DC waveform only |
| Range | -1.000 V to +1.000 V, into a 50 Ω load -2.500 V to +2.500 V, into a 50 Ω load (Option 05) |
| Resolution | 1 mV |

Table 1-16: Funcion Generator (FG) (Cont.)

| Characteristics | Description | | | | | | | | | | | | | | | | |
|------------------------|---|-----------|------------|-----------------------|--------------|------------------------|-------------|------------------------|------------|------------------------|------------|------------------------|------------|------------------------|-------------|------------------------|-------------|
| Phase | AWG420 and AWG430 only | | | | | | | | | | | | | | | | |
| Range | -360 degree to +360 degree | | | | | | | | | | | | | | | | |
| Resolution | <table> <thead> <tr> <th>Frequency</th> <th>Resolution</th> </tr> </thead> <tbody> <tr> <td>1.000 Hz to 20.00 kHz</td> <td>0.036 degree</td> </tr> <tr> <td>20.01 kHz to 200.0 kHz</td> <td>0.36 degree</td> </tr> <tr> <td>200.1 kHz to 2.000 MHz</td> <td>3.6 degree</td> </tr> <tr> <td>2.001 MHz to 4.000 MHz</td> <td>7.2 degree</td> </tr> <tr> <td>4.001 MHz to 5.000 MHz</td> <td>9.0 degree</td> </tr> <tr> <td>5.001 MHz to 8.000 MHz</td> <td>14.4 degree</td> </tr> <tr> <td>8.001 MHz to 10.00 MHz</td> <td>18.0 degree</td> </tr> </tbody> </table> | Frequency | Resolution | 1.000 Hz to 20.00 kHz | 0.036 degree | 20.01 kHz to 200.0 kHz | 0.36 degree | 200.1 kHz to 2.000 MHz | 3.6 degree | 2.001 MHz to 4.000 MHz | 7.2 degree | 4.001 MHz to 5.000 MHz | 9.0 degree | 5.001 MHz to 8.000 MHz | 14.4 degree | 8.001 MHz to 10.00 MHz | 18.0 degree |
| Frequency | Resolution | | | | | | | | | | | | | | | | |
| 1.000 Hz to 20.00 kHz | 0.036 degree | | | | | | | | | | | | | | | | |
| 20.01 kHz to 200.0 kHz | 0.36 degree | | | | | | | | | | | | | | | | |
| 200.1 kHz to 2.000 MHz | 3.6 degree | | | | | | | | | | | | | | | | |
| 2.001 MHz to 4.000 MHz | 7.2 degree | | | | | | | | | | | | | | | | |
| 4.001 MHz to 5.000 MHz | 9.0 degree | | | | | | | | | | | | | | | | |
| 5.001 MHz to 8.000 MHz | 14.4 degree | | | | | | | | | | | | | | | | |
| 8.001 MHz to 10.00 MHz | 18.0 degree | | | | | | | | | | | | | | | | |
| Polarity | Normal, Inverted | | | | | | | | | | | | | | | | |
| Duty | | | | | | | | | | | | | | | | | |
| Range | 0.1 % to 99.9 % | | | | | | | | | | | | | | | | |
| Resolution | <table> <thead> <tr> <th>Frequency</th> <th>Resolution</th> </tr> </thead> <tbody> <tr> <td>1.000 Hz to 200.0 kHz</td> <td>0.1 %</td> </tr> <tr> <td>200.1 kHz to 2.000 MHz</td> <td>1.0 %</td> </tr> <tr> <td>2.001 MHz to 4.000 MHz</td> <td>2.0 %</td> </tr> <tr> <td>4.001 MHz to 5.000 MHz</td> <td>2.5 %</td> </tr> <tr> <td>5.001 MHz to 8.000 MHz</td> <td>4.0 %</td> </tr> <tr> <td>8.001 MHz to 10.00 MHz</td> <td>5.0 %</td> </tr> </tbody> </table> | Frequency | Resolution | 1.000 Hz to 200.0 kHz | 0.1 % | 200.1 kHz to 2.000 MHz | 1.0 % | 2.001 MHz to 4.000 MHz | 2.0 % | 4.001 MHz to 5.000 MHz | 2.5 % | 5.001 MHz to 8.000 MHz | 4.0 % | 8.001 MHz to 10.00 MHz | 5.0 % | | |
| Frequency | Resolution | | | | | | | | | | | | | | | | |
| 1.000 Hz to 200.0 kHz | 0.1 % | | | | | | | | | | | | | | | | |
| 200.1 kHz to 2.000 MHz | 1.0 % | | | | | | | | | | | | | | | | |
| 2.001 MHz to 4.000 MHz | 2.0 % | | | | | | | | | | | | | | | | |
| 4.001 MHz to 5.000 MHz | 2.5 % | | | | | | | | | | | | | | | | |
| 5.001 MHz to 8.000 MHz | 4.0 % | | | | | | | | | | | | | | | | |
| 8.001 MHz to 10.00 MHz | 5.0 % | | | | | | | | | | | | | | | | |
| Marker Out | | | | | | | | | | | | | | | | | |
| Pulse Width | | | | | | | | | | | | | | | | | |
| Mrker1 | Hi : 0 % to 20 % of 1 waveform period Lo : 20% to 100 % of 1 waveform period | | | | | | | | | | | | | | | | |
| Marker2 | Hi : 0 % to 50 % of 1 waveform period Lo : 50 % to 100 % of 1 waveform period Hi : 0 % to 52 % of 1 waveform period Lo : 52 % to 100 % of 1 waveform period at frequency range is 5.001MHz to 8.000MHz | | | | | | | | | | | | | | | | |
| Level | 74LVC541A Output Driver | | | | | | | | | | | | | | | | |
| Hi | 2.4 V min into a 50 Ω load / 4.8 V min into a 1 M Ω load | | | | | | | | | | | | | | | | |
| Lo | 0.1 V max into a 50 Ω load / 0.2 V max into a 1 M Ω load | | | | | | | | | | | | | | | | |

Table 1-17: Display

| Characteristics | Description |
|-----------------|--------------------------|
| Display | |
| Display area | |
| Horizontal | 130.6 mm (5.14 in) |
| Vertical | 97.0 mm (3.81 in) |
| Resolution | 640 (H) × 480 (V) pixels |

Table 1-18: Power Supply

| Characteristics | Description |
|---------------------|---|
| Power Supply | |
| Rating voltage | 100 V _{AC} to 240 V _{AC} |
| Voltage range | 90 V _{AC} to 250 V _{AC} |
| Frequency range | 48 Hz to 63 Hz |
| Maximum power | 340 VA _{max} |
| Fuse rating | 10 A fast, 250 V, UL 198G (3 AG) 5 A (T), 250 V, IEC 127 |

Table 1-19: Timer

| Characteristics | Description |
|------------------------|-----------------|
| Timer (battery) | |
| Operation life | 6 years |
| Type | Li 3 V, 190 mAh |

Table 1-20: Interface connectors

| Characteristics | Description |
|-------------------------|---|
| Interface | |
| GPIO | 24-pin, IEEE 488.1 connector on the rear panel |
| Ethernet | 100/10 BASE-T, RJ-45 connector on the rear panel |
| Keyboard connector | 6-pin, mini-DIN connector on the rear panel |
| Optional port connector | 9-pin, Dsub connector on the rear panel; this connector may be used in a future optional function. Usually, it is equipped with a dust cap. |

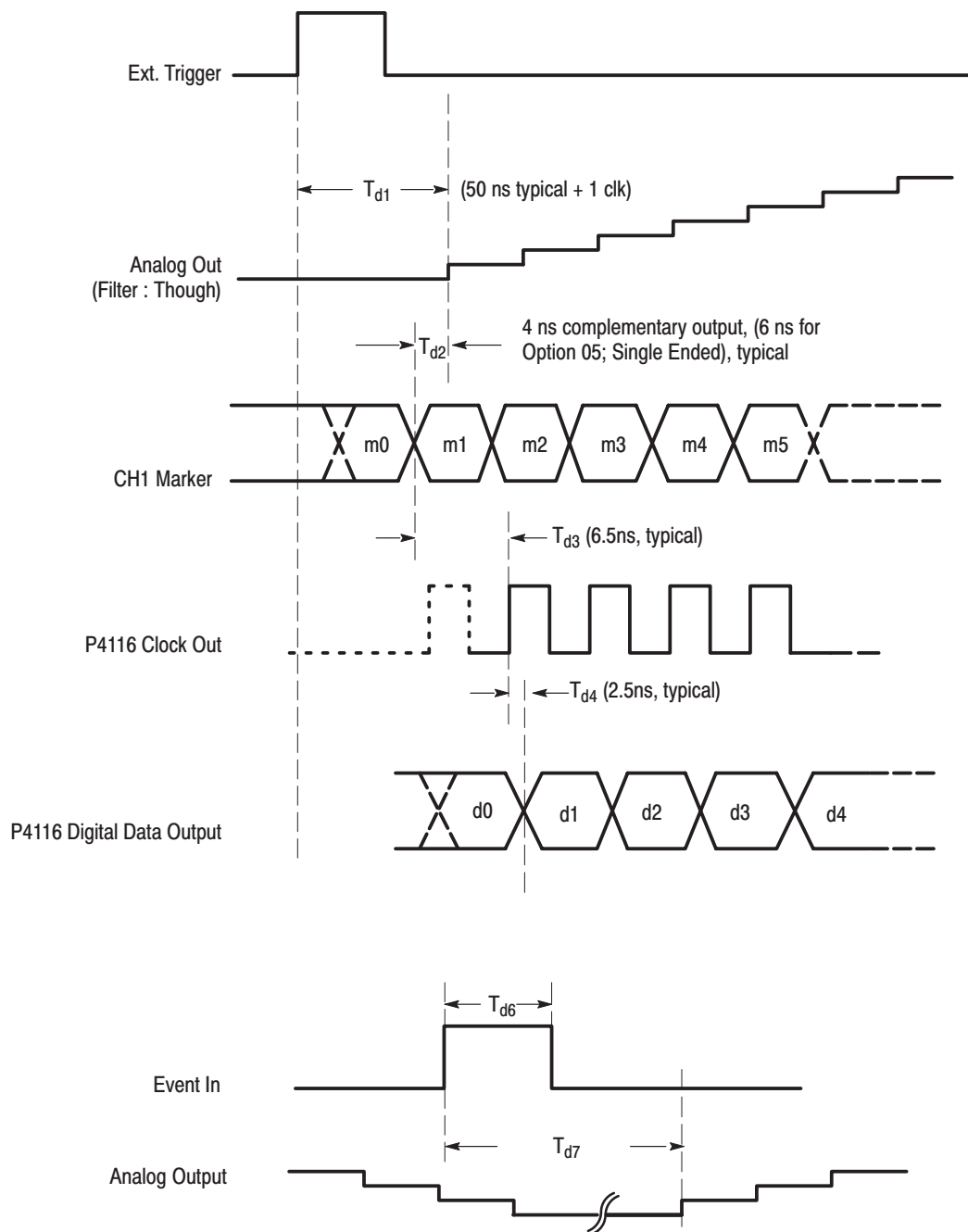

Figure 1-3: Signal timing

Table 1-21: Installation requirement

| Characteristics | Description |
|---|---|
| Heat dissipation | |
| Maximum power Dissipation (Fully loaded) | 310 W maximum (maximum line current: 4 A _{rms} at 50 Hz, 90 V line, with 5% clipping) |
| Surge current | 30 A peak (25° C) for equal to or less than 5 line cycles, after the instrument has been turned off for at least 30 seconds. |
| Cooling clearance | |
| Top and Bottom | 2 cm (0.8 in) <i>NOTE: The feet on the bottom provide the required clearance when set on a flat surface.</i> |
| Sides | 15 cm (6 in) |
| Rear | 7.5 cm (3 in) |

Table 1-22: Environmental

| Characteristics | Description |
|---------------------|---|
| Atmospherics | |
| Temperature | |
| Operating | +10° C to +40° C |
| Nonoperating | -20° C to +60° C |
| Relative humidity | |
| Operating | 20% to 80% (no condensation) Maximum wet-bulb temperature 29.4° C |
| Nonoperating | 5% to 90% (no condensation) Maximum wet-bulb temperature 40.0° C |
| Altitude | (Hard disk drive restriction) |
| Operating | Up to 3 km (10,000 ft) Maximum operating temperature decreases 1° C each 300 m (1,000 ft) above 1.5 km (5,000 ft) |
| Nonoperating | Up to 12 km (50,000 ft) |
| Dynamics | |
| Random vibration | |
| Operating | 2.646 m/s ² (0.27 G _{rms}), from 5 Hz to 500 Hz, 10 minutes |
| Nonoperating | 22.344 m/s ² (2.28 G _{rms}), from 5 Hz to 500 Hz, 10 minutes |
| Shock | |
| Nonoperating | 294 m/s ² (30 G), half-sine, 11 ms duration. |

Table 1-23: Mechanical

| Characteristics | Description |
|-------------------------------------|---|
| Net weight (without package) | |
| AWG410 (Standard) | approximately 13.7kg (30.2 lb) |
| AWG420 (Standard) | approximately 14.1kg (31.1 lb) |
| AWG430 (Standard) | approximately 14.4kg (31.7 lb) |
| Dimensions (without package) | |
| Height | 177 mm (6.97 in) without feet 193 mm (7.60 in) including feet |
| Width | 424 mm (16.69 in) without handle 433 mm (17.05 in) including handle |
| Length | 470 mm (18.50 in) without back feet 508 mm (20.00 in) including back feet |
| Net weight (without package) | approximately 13.7 kg (30.2 lb), AWG410 approximately 14.1 kg (31.1 lb), AWG420 approximately 14.4 kg (31.7 lb), AWG430 |
| Net weight (with package) | approx. 22.3 kg (49.12 lb), AWG430 (Standard) |
| Dimensions (with package) | |
| Height | 400 mm (15.75 in) |
| Width | 550 mm (21.65 in) |
| Length | 700 mm (27.56 in) |

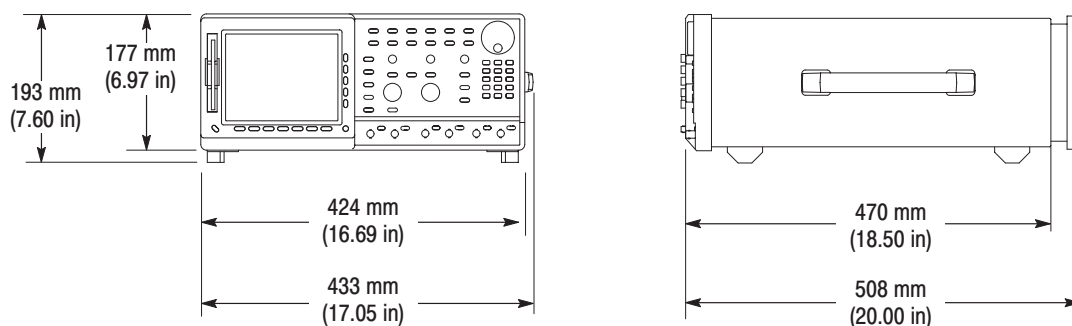

Figure 1-4: Dimensions

Certification and Compliances

The certification and compliances for the AWG400-Series Arbitrary Waveform Generator are listed in Table 1–24.

Table 1–24: Certifications and compliances

| Characteristics | Description | | | | | | | | | | | | | | | | | | | | | | |
|---|--|-----------------|---|--------------|----------------------------------|--------------|-------------------------------------|--------------|----------------------------------|--------------|-----------------------------------|--------------|------------------------------------|--------------|----------------|---------------------------|---|--------------|---------------------------------------|---------------|----------------------------------|--------------------|---|
| EC declaration of conformity | <p>Meets intent of Directive 89/336/EEC for Electromagnetic Compatibility. Compliance was demonstrated to the following specifications as listed in the Official Journal of the European Communities:</p> <table border="0"> <tr> <td>EN 61326</td> <td>EMC requirements for Class A electrical equipment for measurement, control and laboratory use.¹</td> </tr> <tr> <td>EN 61000-3-2</td> <td>AC Power Line Harmonic Emissions</td> </tr> <tr> <td>EN 61000-3-3</td> <td>Line voltage alteration and flicker</td> </tr> <tr> <td>EN 61000-4-2</td> <td>Electrostatic Discharge Immunity</td> </tr> <tr> <td>EN 61000-4-3</td> <td>RF Electromagnetic Field Immunity</td> </tr> <tr> <td>EN 61000-4-4</td> <td>Electrical Fast Transient Immunity</td> </tr> <tr> <td>EN 61000-4-5</td> <td>Surge Immunity</td> </tr> <tr> <td>EN 61000-4-6²</td> <td>Conducted Disturbances Induced by RF Fields</td> </tr> <tr> <td>EN 61000-4-8</td> <td>Power Frequency Electromagnetic Field</td> </tr> <tr> <td>EN 61000-4-11</td> <td>Power Line Interruption Immunity</td> </tr> </table> <p>Compliance was demonstrated to the following specification as listed in the Official Journal of the European Communities:</p> <p>Low Voltage Directive 73/23/EEC</p> <table border="0"> <tr> <td>EN 61010-1/A2:1995</td> <td>Safety requirements for electrical equipment for measurement, control, and laboratory use</td> </tr> </table> | EN 61326 | EMC requirements for Class A electrical equipment for measurement, control and laboratory use. ¹ | EN 61000-3-2 | AC Power Line Harmonic Emissions | EN 61000-3-3 | Line voltage alteration and flicker | EN 61000-4-2 | Electrostatic Discharge Immunity | EN 61000-4-3 | RF Electromagnetic Field Immunity | EN 61000-4-4 | Electrical Fast Transient Immunity | EN 61000-4-5 | Surge Immunity | EN 61000-4-6 ² | Conducted Disturbances Induced by RF Fields | EN 61000-4-8 | Power Frequency Electromagnetic Field | EN 61000-4-11 | Power Line Interruption Immunity | EN 61010-1/A2:1995 | Safety requirements for electrical equipment for measurement, control, and laboratory use |
| EN 61326 | EMC requirements for Class A electrical equipment for measurement, control and laboratory use. ¹ | | | | | | | | | | | | | | | | | | | | | | |
| EN 61000-3-2 | AC Power Line Harmonic Emissions | | | | | | | | | | | | | | | | | | | | | | |
| EN 61000-3-3 | Line voltage alteration and flicker | | | | | | | | | | | | | | | | | | | | | | |
| EN 61000-4-2 | Electrostatic Discharge Immunity | | | | | | | | | | | | | | | | | | | | | | |
| EN 61000-4-3 | RF Electromagnetic Field Immunity | | | | | | | | | | | | | | | | | | | | | | |
| EN 61000-4-4 | Electrical Fast Transient Immunity | | | | | | | | | | | | | | | | | | | | | | |
| EN 61000-4-5 | Surge Immunity | | | | | | | | | | | | | | | | | | | | | | |
| EN 61000-4-6 ² | Conducted Disturbances Induced by RF Fields | | | | | | | | | | | | | | | | | | | | | | |
| EN 61000-4-8 | Power Frequency Electromagnetic Field | | | | | | | | | | | | | | | | | | | | | | |
| EN 61000-4-11 | Power Line Interruption Immunity | | | | | | | | | | | | | | | | | | | | | | |
| EN 61010-1/A2:1995 | Safety requirements for electrical equipment for measurement, control, and laboratory use | | | | | | | | | | | | | | | | | | | | | | |
| Australian declaration of conformity — EMC \ | <p>Conforms with the following standards in accordance with the Electromagnetic Compatibility Framework:</p> <table border="0"> <tr> <td>AS/NZS 2064.1/2</td> <td>Class A radiated and Conducted Emissions</td> </tr> </table> | AS/NZS 2064.1/2 | Class A radiated and Conducted Emissions | | | | | | | | | | | | | | | | | | | | |
| AS/NZS 2064.1/2 | Class A radiated and Conducted Emissions | | | | | | | | | | | | | | | | | | | | | | |
| Safety | UL3111-1 — Standard for electrical measuring and test equipment | | | | | | | | | | | | | | | | | | | | | | |
| Third party certification | CAN/CSA C22.2 No. 1010.1 — Safety requirements for electrical equipment for measurement, control and laboratory use | | | | | | | | | | | | | | | | | | | | | | |
| Self declaration | IEC 61010-1/A2:1995 — Safety requirements for electrical equipment for measurement, control, and laboratory use | | | | | | | | | | | | | | | | | | | | | | |
| Installation category | Power input — Installation Category II (as defined in IEC 61010-1, Annex J) | | | | | | | | | | | | | | | | | | | | | | |
| Pollution degree | Pollution Degree 2 (as defined in IEC 61010-1) | | | | | | | | | | | | | | | | | | | | | | |
| ¹ | Emissions which exceed the levels required by this standard may occur when this equipment is connected to a test object. | | | | | | | | | | | | | | | | | | | | | | |
| ² | Up to 200 mV_{p-p} noise is allowed on the output during this test. | | | | | | | | | | | | | | | | | | | | | | |

Table 1-25: Installation category and pollution degree descriptions

| Characteristics | Description | | |
|------------------------------|--|--|---------------------|
| Installation category | Terminals on this product may have different installation category designations. The installation categories are: | | |
| | <table border="1"> <thead> <tr> <th data-bbox="589 464 862 506"><i>Category</i></th> <th data-bbox="862 464 1500 506"><i>Description</i></th> </tr> </thead> </table> | <i>Category</i> | <i>Description</i> |
| | <i>Category</i> | <i>Description</i> | |
| | CAT III | Distribution-level mains (usually permanently connected). Equipment at this level is typically in a fixed industrial location. | |
| CAT II | Local-level mains (wall sockets). Equipment at this level includes appliances, portable tools, and similar products. Equipment is usually cord-connected. | | |
| CAT I | Secondary (signal level) or battery operated circuits of electronic equipment. | | |
| Pollution degree | A measure of the contaminates that could occur in the environment around and within a product. Typically the internal environment inside a product is considered to be the same as the external. Products should be used only in the environment for which they are rated. | | |
| | <table border="1"> <thead> <tr> <th data-bbox="589 890 862 932"><i>Category</i></th> <th data-bbox="862 890 1500 932"><i>Descriptions</i></th> </tr> </thead> </table> | <i>Category</i> | <i>Descriptions</i> |
| | <i>Category</i> | <i>Descriptions</i> | |
| | Pollution Degree 1 | No pollution or only dry, nonconductive pollution occurs. Products in this category are generally encapsulated, hermetically sealed, or located in clean rooms. | |
| | Pollution Degree 2 | Normally only dry, nonconductive pollution occurs. Occasionally a temporary conductivity that is caused by condensation must be expected. This location is a typical office/home environment. Temporary condensation occurs only when the product is out of service. | |
| Pollution Degree 3 | Conductive pollution, or dry, nonconductive pollution that becomes conductive due to condensation. These are sheltered locations where neither temperature nor humidity is controlled. The area is protected from direct sunshine, rain, or direct wind. | | |
| Pollution Degree 4 | Pollution that generates persistent conductivity through conductive dust, rain, or snow. Typical outdoor locations. | | |

Preparation for Use

This subsection provides the following information:

- *Supplying Operating Power*
- *Operating Environment*
- *Installation*
- *Repackaging Instructions*

Supplying Operating Power



WARNING. *To avoid equipment failure and potential fire or personal shock hazards, do not exceed the maximum rated operating voltage of 250 V between the voltage-to-ground (earth) and either pole of the power source. The AWG400-Series operates from a single-phase power source and has a three-wire power cord with a two-pole, three-terminal grounding plug. Before making connection to the power source, be sure the AWG400-Series has a suitable two-pole, three-terminal, grounding-type plug.*

To avoid personal shock hazard, do not touch conductive parts. All accessible conductive parts are directly connected through the grounding conductor of the power cord to the grounded (earth) contact of the power plug. The AWG400-Series is safety Class 1 equipment (IEC designation).

*To prevent electrical shock, remove all power from the instrument, switch the **PRINCIPAL POWER SWITCH** on the back panel to OFF, and disconnect the power cord from the instrument. Some components in the AWG400-Series are still connected to line voltage after powering off the instrument from the front-panel **ON/STBY** button.*

Power Cord Information

A power cord with the appropriate plug configuration is supplied with each AWG400-Series. Table 2–1 gives the color-coding of the conductors in the power cord. If you require a power cord other than the one supplied, refer to Table 2–2.

Table 2-1: Power-cord conductor identification

| Conductor | Color | Alternate Color |
|---------------------|--------------|-----------------|
| Ungrounded (Line) | Brown | Black |
| Grounded (Neutral) | Light Blue | White |
| Grounded (Earthing) | Green/Yellow | Green |

Table 2-2: Power cord identification

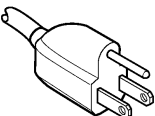
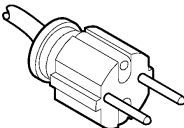
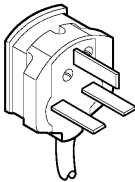
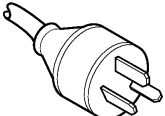
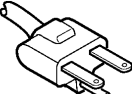
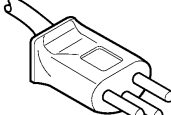
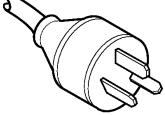
| Plug configuration | Normal usage | Option number |
|---|--|---------------|
|  | North America 125 V/15 A Plug NEMA 5-15P | Standard |
|  | Europe 230 V | A1 |
|  | United Kingdom 230 V | A2 |
|  | Australia 230 V | A3 |
|  | North America 230 V | A4 |
|  | Switzerland 230 V | A5 |
|  | China 230 V | AC |
| | No power cord supplied. | A99 |

Operating Voltage This AWG400-Series operates with any line voltage from 100 to 240 VAC_{RMS} with any line frequency from 48 to 63 Hz. There are two fuses, either of which may be used throughout the line voltage and frequency ranges. (The two fuses are not interchangeable as each requires a different fuse cap.)

Memory Backup Power Memory modules with on-board batteries allow the AWG400-Series to retain internal clock data upon loss of the AC power source.

To set the date and time in the waveform generator, see the *Reference:Internal Clock (Date and Time)* section of the AWG400-Series user manual.

Operating Environment

The following environmental requirements are provided to ensure proper operation and long instrument life.

Operating Temperature Operate the waveform generator where the ambient air temperature is from 10° C to +40° C (50° F to 104° F). Store the waveform generator in ambient temperatures from –20° C to +60° C (–40° F to 140° F). After storage at temperatures outside the operating limits, allow the chassis to stabilize to a safe operating temperature before applying power.

Ventilation Requirements The waveform generator is cooled by air drawn in and exhausted through the cabinet side panels by an internal fan. To ensure proper cooling of the waveform generator, allow at least 15 cm (6 inches) clearance on both sides, 2.0 cm (0.8 inches) on the top and bottom, and 7.5 cm (3 inches) on the rear of the waveform generator. (The feet on the bottom of the waveform generator provide the required clearance when set on flat surfaces.)



CAUTION. When the air flow is restricted and the temperature of the DAC module surface goes over 80° C (176° F), the AWG400-Series may temporarily shut down to protect the internal modules. To prevent temporary shutdown of the AWG400-Series, do not restrict air flow through the chassis.

The AWG400-Series displays the message “Power fail or out of temperature limit” before shutting down.

If the AWG400-Series shuts down unexpectedly, improve ventilation around the AWG400-Series and wait a few minutes to allow it to cool down; then switch the power on again.

Installation

Before installation, refer to the *Safety Summary* section at the front of this manual for power source, grounding, and other safety information.

Environment

Verify that you have the correct operating environment.



CAUTION. *To prevent damage to the instrument, do not power on the instrument at temperatures outside the specified temperature range.*

The AWG400-Series operates correctly in ambient temperatures from +10° C to +40° C (50° F to 104° F) and relative humidity from 20% to 80% with no condensation. If the instrument is stored at temperatures outside this range, do not switch on the power until the chassis has come within the operating temperature range. For more operating environment information, refer to *Specifications* on page 1–3 or 1–18.

NOTE. *If you are installing the instrument in a rack, refer to the instruction sheet that comes with the rack-mounting kit for proper installation procedures.*

Verify that there is nothing blocking the flow of air at the fan and air intake holes. The instrument exhausts air with the fan on its left side. Leave space at the sides of the instrument so that the instrument does not overheat. The following are the minimum space requirements for air flow around the instrument:

| | |
|----------------|----------------|
| Rear | 7.5 cm (3 in) |
| Left and right | 15.0 cm (6 in) |
| Top and Bottom | 2 cm (0.8 in) |

(The feet on the bottom of the instrument provide the required clearance when set on a flat surface.)

NOTE. *If the air flow is restricted and the internal temperature of the AWG400-Series exceeds the proper operating temperature range, the instrument temporarily shuts down to protect the internal modules from overheating. To prevent temporary shutdown of the AWG400-Series, do not restrict air flow through the chassis.*

If the AWG400-Series shuts down unexpectedly, improve ventilation around the AWG400-Series, and wait a few minutes to allow it to cool down; then switch the power on again.

NOTE. You cannot power on the instrument when the ambient temperature exceeds the operating temperature range of the instrument. Wait until the instrument cools down, or the ambient temperature decreases to valid operating temperatures, before turning on the instrument again.

Check Fuse

Check the fuse to be sure that it is the proper type and rating.

Remove the fuse from the fuse holder on the rear panel and check the fuse. To remove the fuse, turn it counterclockwise with a screwdriver while pushing in on the screwdriver. There are two types of fuses provided. Tables 2–3 and Table 2–4 list the fuse types and ratings.



WARNING. To avoid electrical shock, be sure that the power cord is disconnected from the socket before checking the line fuse.

Table 2-3: Fuse part numbers

| Fuse | Fuse part number |
|---|------------------|
| Fuse, cartridge, 3AG, 10A, 250 VAC, FAST, 6.35 mm x 31.75 mm (0.25 in x 1.25 in) | 159-0407-XX |
| Fuse, cartridge, DIN 5 x 20 mm, 5A, 250 V Slow Blow, 5 mm x 20 mm (.197 in x .788 in) (IEC 127) | 159-0210-XX |

NOTE. The second fuse listed in the table above is approved under the IEC standards. This fuse is used in equipment sold in the European market.

Table 2-4: Fuse cap part numbers

| Fuse cap | Fuse cap part number |
|--------------------------------|----------------------|
| Cap, fuseholder, 3AG fuses | 200-2264-XX |
| Cap, fuseholder, 5x20 mm fuses | 200-2265-XX |

Check Voltage Settings

Check that you have the proper electrical connections. The AWG400-Series generator operates within the following power supply voltage and frequency ranges:

| | |
|---------------------------|--------------------------|
| Line voltage range | 100 – 240 V |
| Line frequency | 48 – 63 Hz (100 – 240 V) |
| Maximum power | 340 W |

Connect Power Cord

Connect the proper power cord from the rear-panel power connector to the power system.

NOTE. *The AWG400-Series is shipped with a 115 V power cord. If the AWG400-Series is to be used with 230 V power, the power cord must be replaced with one appropriate for the power source used. See Table 2–2 on page 2–2 for the available power cord types.*

Standby Power Push the **PRINCIPAL POWER SWITCH** (shown in Figure 2–1) on the rear panel of the instrument. Power is now applied to the instrument standby circuitry. Once the instrument is installed, leave the **PRINCIPAL POWER SWITCH** on and use the **ON/STBY** switch, located on the front panel, to turn the instrument on and off.

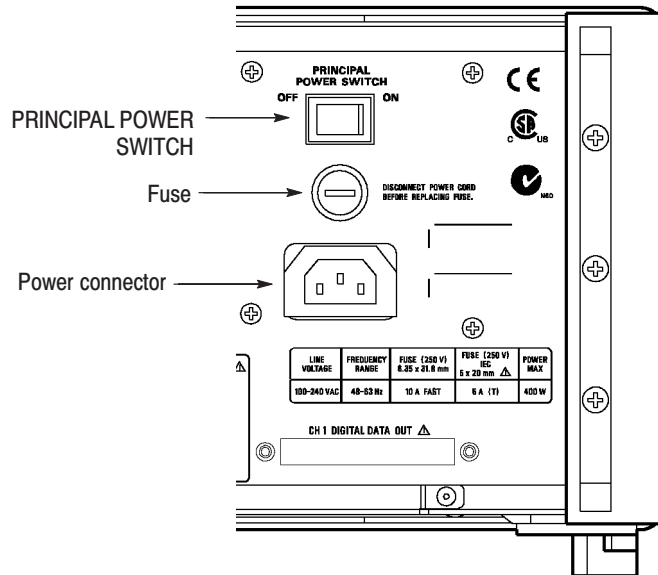

Figure 2-1: Rear panel power switch, fuse holder, and power connector

Power On Push the **ON/STBY** switch (shown in Figure 2–2) on the lower left side of the front panel to power on the instrument. Check that the fan is blowing air out of the instrument.

NOTE. *The instrument needs to be warmed up for at least 20 minutes and the clock calibrated to operate at its optimum accuracy.*

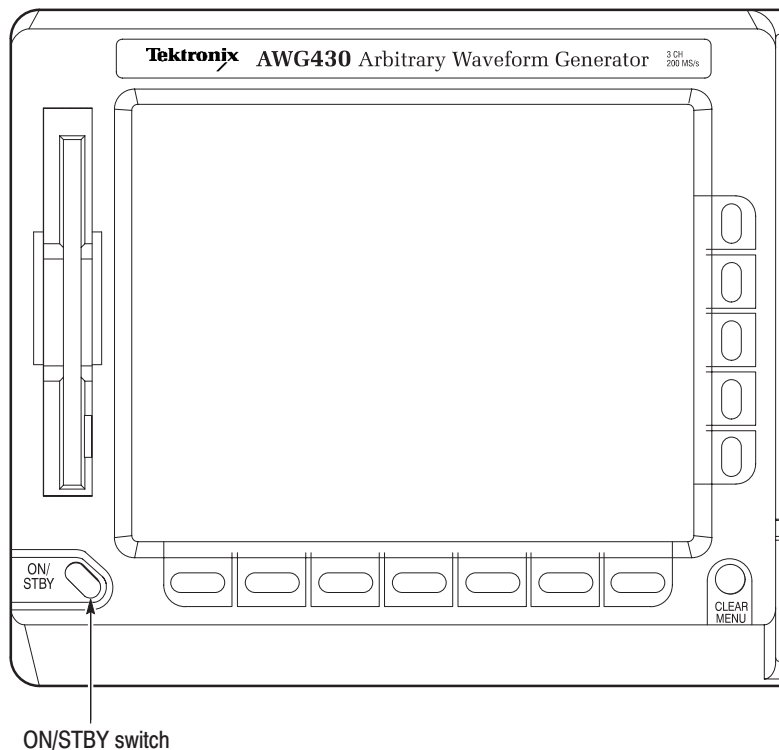

Figure 2-2: Location of the ON/STBY switch

Power-On Diagnostics

The instrument automatically runs power-on self tests to check that the instrument is operating normally.

Check the results of the power-on self tests. If all the diagnostic tests are completed without error, the instrument displays *Pass* and then displays the SETUP menu screen.

If the system detects an error, the instrument displays *Fail* and the error code number on the screen. You can still operate the instrument if you exit this state, but the wave output accuracy is not guaranteed until the error is corrected. To exit the diagnosis mode, push any button. The system goes to the SETUP menu screen.

NOTE. Contact your local Tektronix Field Office or representative if the instrument displays an error message. Make sure to record the error code number.

Power Off

To power off the AWG400-Series, push the **ON/STBY** switch on the front panel.



WARNING. To prevent electrical shock, remove all power from the instrument, turn the **PRINCIPAL POWER SWITCH** on the back panel to *OFF*, and disconnect the power cord from the instrument. Some components in the AWG400-Series are still connected to line voltage after powering off the instrument from the front-panel **ON/STBY** button.

To prevent the loss of data and/or damage to the hard disk, before powering off, confirm that the LED on the hard disk at the lower right of the front panel is not lighted or blinking.

Repackaging for Shipment

If this instrument is shipped by commercial transportation, use the original packaging material. If the original packaging is unfit for use or is not available, repackage the instrument as follows:

1. Obtain a corrugated cardboard shipping carton having inside dimensions at least 7.62 cm (3 in) greater than the instrument dimensions and having a carton test strength of at least 125 kg (275 lbs).
2. If the instrument is being shipped to a Tektronix Service Center for repair or calibration, attach a tag to the instrument showing the following information:
 - The owner of the instrument (with address).
 - The name of a person at your firm who may be contacted if additional information is needed.
 - The complete instrument type and serial number.
 - A description of the service required.
3. Wrap the instrument with polyethylene sheeting or equivalent to protect the outside finish and prevent entry of packing materials into the instrument.
4. Cushion the instrument on all sides by tightly packing dunnage or urethane foam between the carton and the instrument, allowing for 7.62 cm (3 in) of padding on each side (including top and bottom).
5. Seal the carton with shipping tape or with an industrial stapler.
6. Mark the address of the Tektronix Service Center and your return address on the carton in one or more prominent locations.

NOTE. *Do not ship the instrument with a diskette inside the floppy disk drive. When a diskette is inside the drive, the disk release button sticks out. This makes the button susceptible to damage.*

Applying and Interrupting Power

Consider the following information when you power on or power off the instrument, or when power is interrupted due to an external power failure.

Power On At power on, the waveform generator runs a power-on self check. If it passes, the AWG400-Series displays a *Pass* status message and a prompt to press any key to continue. If it fails, the AWG400-Series displays a diagnostic log that identifies the area(s) that failed and a prompt to press any key to continue. Refer to the *Maintenance* section for information on diagnostics and fault isolation.

Power Off



CAUTION. *DO NOT power off the waveform generator when either running a signal path compensation or when doing any of the adjustments described in the Adjustment Procedures section. To do so might result in the loss of internally stored adjustment constants.*

In general, do not power off the instrument when doing operations that affect the data stored in the memory. Wait for the instrument to finish the operation when doing adjustments, saving waveforms, or saving setups.

Improper power off or unexpected loss of power to the AWG400-Series can result in calibration data corruptions on the hard disk.

Operating Basics

This section provides the following information:

- The *Controls and Connectors* subsection describes the instrument buttons, controls, connectors, and typical screen displays.
- The *Menu Operations* subsection describes how to operate menus and enter numeric and text values.
- The *Shortcut Controls* subsection shows you specific controls that allow you to adjust output setup parameters while you are displaying another menu.
- The *File Management* subsection contains information about file management, such as locating, naming, copying, saving and deleting files.
- The *Double Windows* subsection describes how to use the Double Windows feature of your instrument.
- The *Quick View* subsection describes how to see the content of a file before loading or handling the file.
- The *Setup Overview* subsection describes the SETUP screen and simple operations, such as loading a waveform file into the setup screen and viewing the loaded waveform.

Controls and Connectors

Front Panel

Figures 2–3 to 2–6 show the locations of the front-panel controls and rear-panel connectors.



CAUTION. *To prevent loss of data, data corruption, and damage to the hard disk, do not push the eject button while the floppy disk or hard disk LED is lighted or blinking. Doing so can cause data corruption and cause the instrument to hang up. If this happens, power the instrument off and then back on again.*

To prevent damage to the instrument, do not apply any external voltage to the output connector or marker connector.

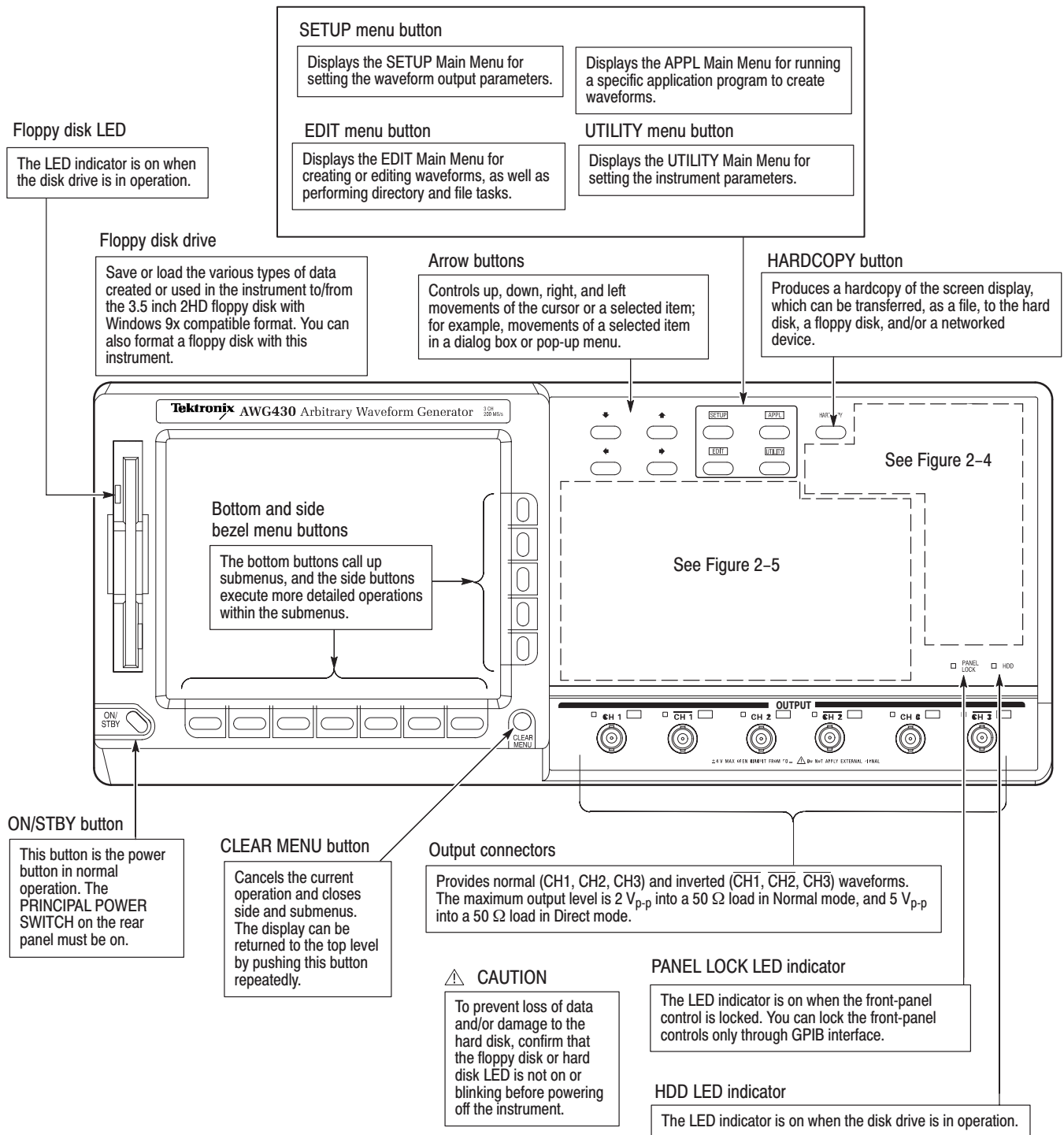

Figure 2-3: Front panel controls

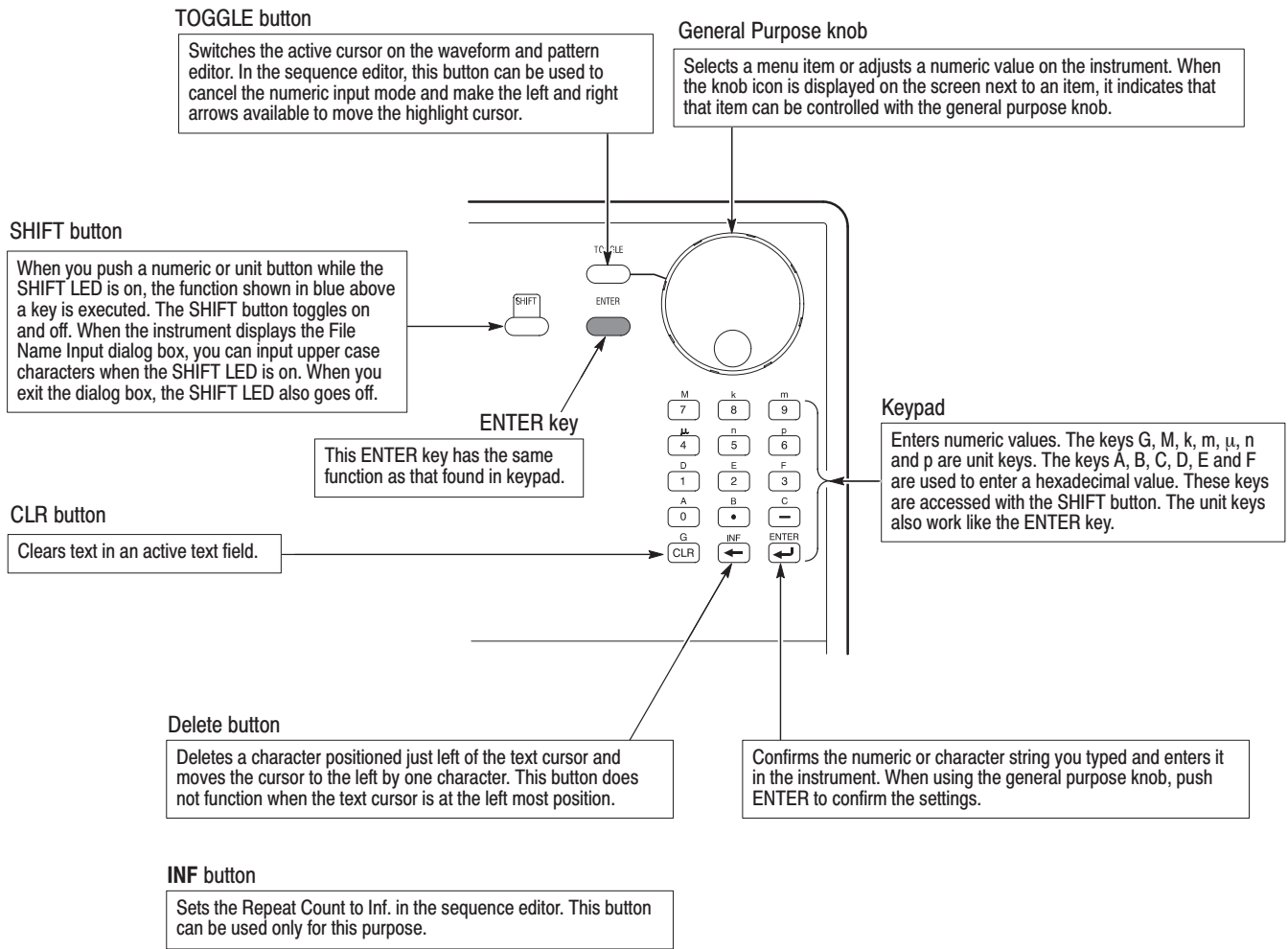

Figure 2-4: Front panel keypad area

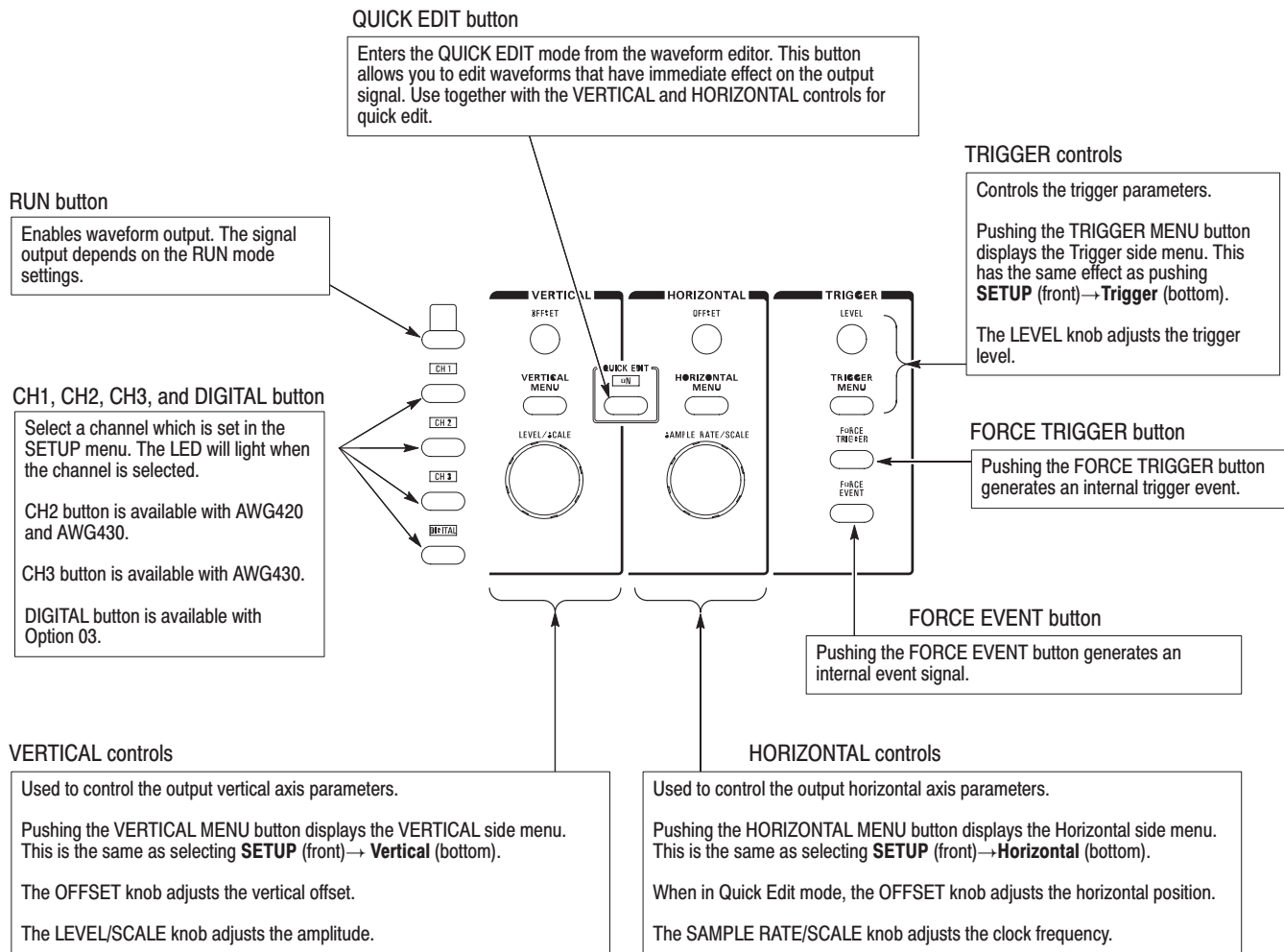

Figure 2-5: Front panel keypad area

Rear Panel

Figure 2-6 shows the rear panel signal and power connectors.



CAUTION. To prevent damage to the instrument, only apply signals within the stipulated range to the **INPUT** connector.

Do not apply any external voltage to the **OUTPUT** connector.

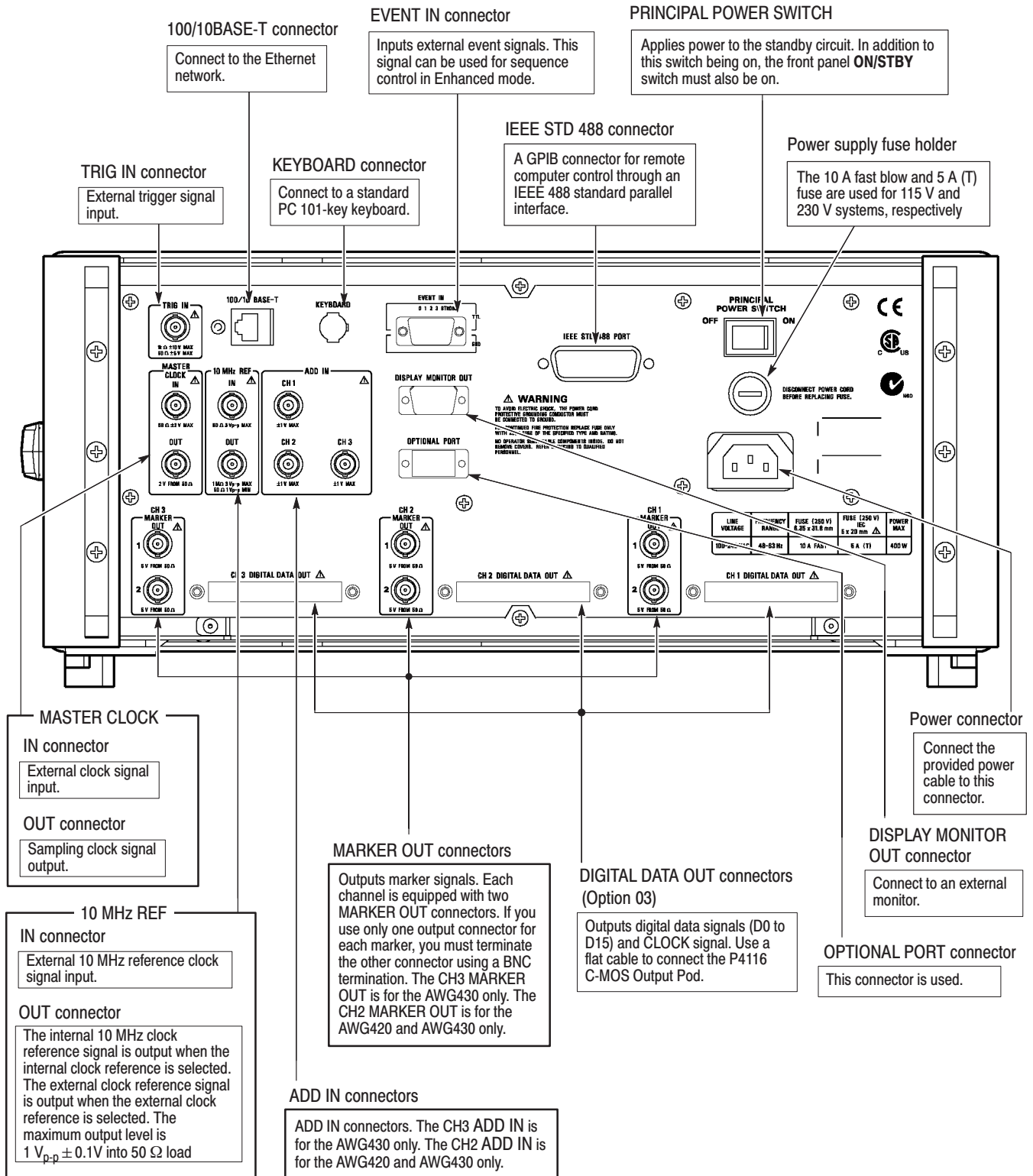

Figure 2-6: Rear panel signal and power connectors

Menu Operations

This section describes the AWG400-Series Arbitrary Waveform Generator menu system and numeric and text input methods.

Menu System

The AWG400-Series Arbitrary Waveform Generator uses menus to make selections. There are four menu buttons, labeled EDIT, SETUP, APPL, and UTILITY, as shown in Figure 2–7. Pushing a menu button displays the corresponding screen and menu buttons. These menus let you edit waveforms, initialize instrument settings, define instrument operation, and specify waveform output parameters.

You select items within the displayed menu by pushing the bottom or side bezel button nearest to the menu item. These buttons consist of seven bottom buttons and five side buttons, as shown in Figure 2–7. These menu bezel buttons are referred to as bottom menu buttons (or bottom buttons) and side menu buttons (or side buttons).

The **CLEAR MENU** button cancels the current menu operation, clears the current menus from the screen, and exits to the previous instrument state.

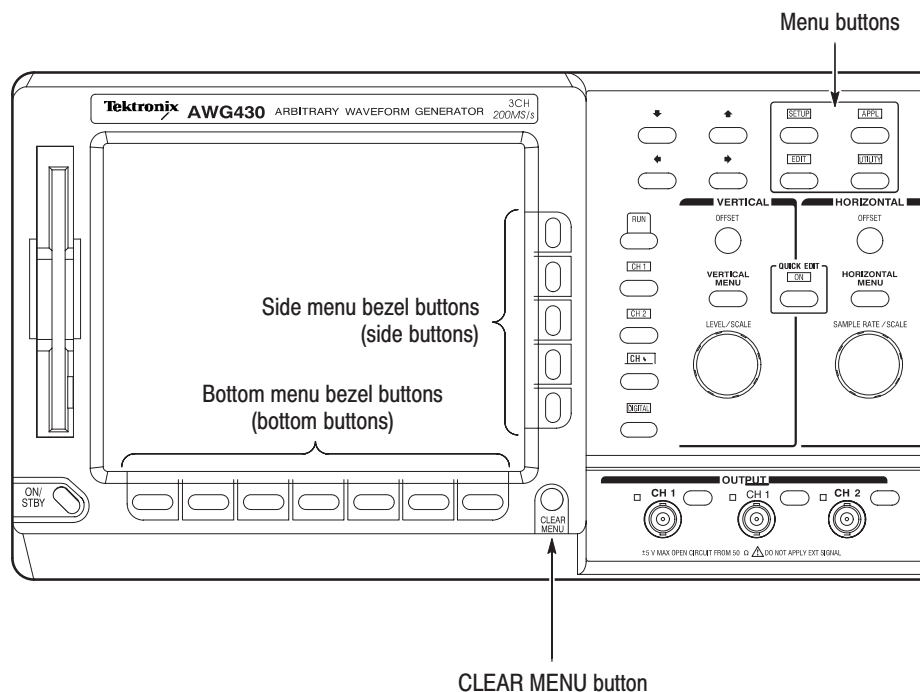

Figure 2–7: Menu buttons, bezel menu buttons, and the CLEAR MENU button

Menu Elements

Pushing a front-panel menu button displays the screen and bottom menu items associated with the button. You select a bottom menu item by pushing the button directly below that menu item.

Pushing a bottom button displays a side menu, pop-up menu, list, or dialog box. Figures 2–8 through 2–10 show examples of the side menu, pop-up menu and dialog box, respectively.

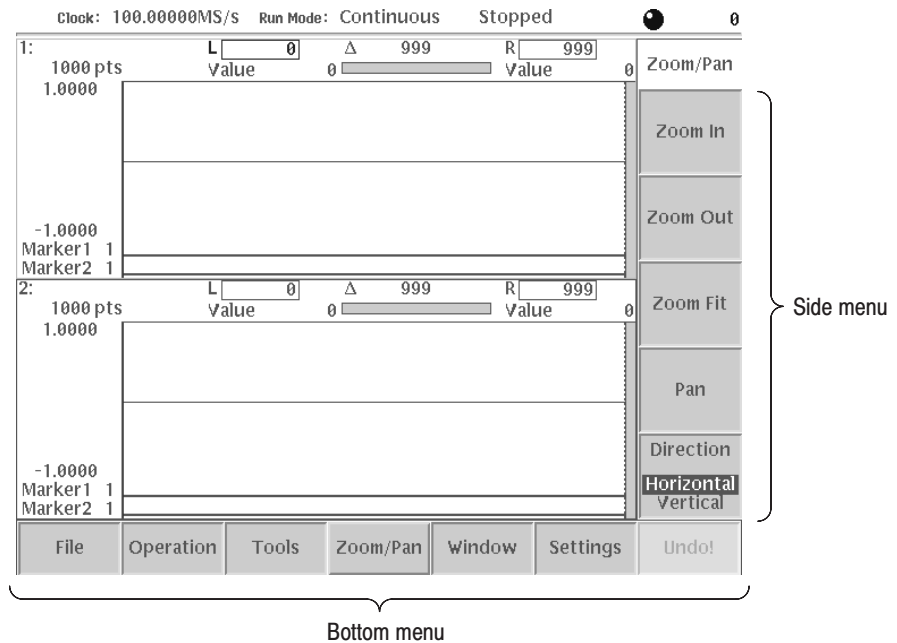

Figure 2–8: Bottom and side menus

You use a side menu button to display a side submenu, set a parameter, perform a task, or cancel an operation. Table 2–5 describes the side menu button types.

Table 2–5: Side menu elements

| Menu items | Description | Menu items | Description |
|----------------------------|---|------------------|--|
| External | Executes the displayed function immediately. | Up Level | Cannot be used in the current instrument state (menu item is grayed out). |
| Output Normal Direct | Toggles between two parameters each time the side button is pushed. | Filter 20 MHz | Allows making selections by using the general purpose knob. |
| Amplitude 1.000Vpp | Allows entering numeric values using the numeric buttons or the general purpose knob. | Add... | Displays submenus. Note that the label on the item is followed by an ellipsis (...). |

The pop-up menu example, shown in Figure 2–9, displays a list of choices from which you make a selection. Use the general purpose knob or the front-panel arrow buttons to move up or down in the list. Push the **OK** side button or the **ENTER** front-panel button to confirm the selected item.

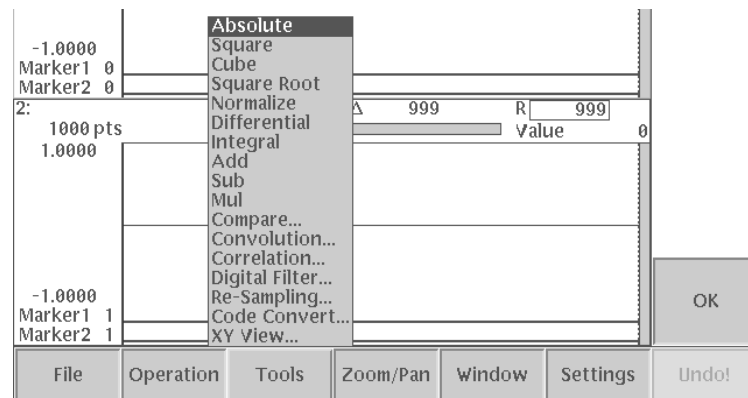

Figure 2–9: Pop-up menu example

The dialog box example, shown in Figure 2–10, and the screen menu example shown in Figure 2–11 displays a form in which you make selections or enter values. Use the front-panel arrow buttons to select items or fields. A selected field or item is highlighted. Use the keypad buttons or the general purpose knob to change values in selected text/numeric fields or change 1-of-N fields. A 1-of-N field contains two or more choices of which only one can be selected at a time.

Push the **OK** side button to confirm the dialog box. Push the **Cancel** side button or the **CLEAR MENU** button to exit the dialog box without making any changes.

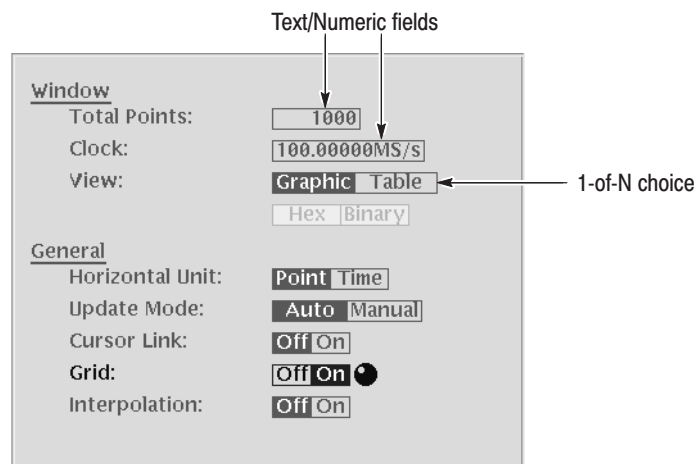

Figure 2–10: Dialog box example

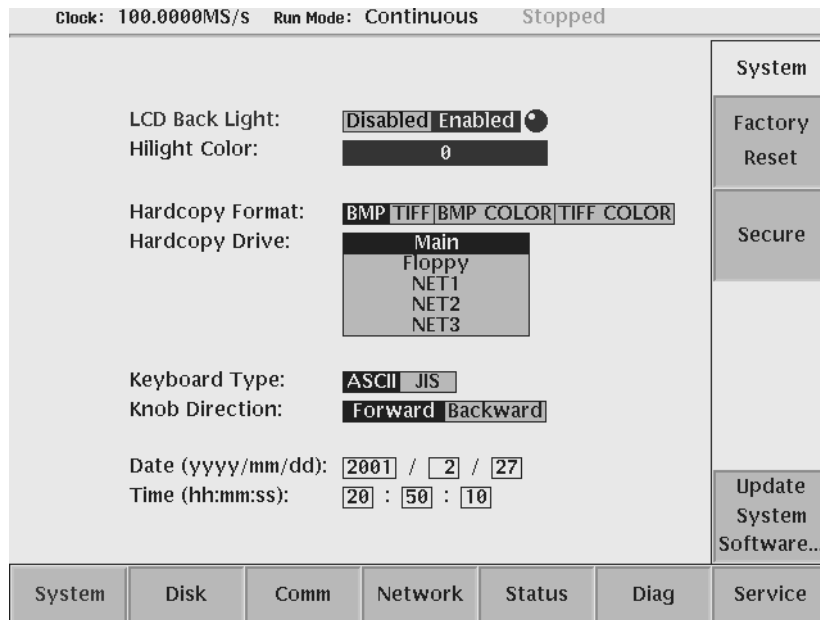
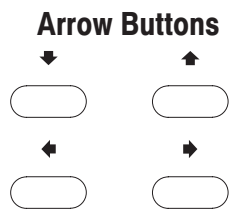

Figure 2-11: Screen menu example



Arrow Buttons

You can use arrow buttons when making selections, moving to the field to change selection.

Use ▲ and ▼ arrow buttons to move a cursor in a pop-up menu, to make a selection in a dialog box, or to move a cursor in the editor menu.

Use ◀ and ▶ arrow buttons to make a selection in a dialog box, to move the input caret when you enter numerics with the general purpose knob, or to move a cursor in the editor menu.

CLEAR MENU button

You can use the **CLEAR MENU** button on the front panel to cancel the bottom menu selection or side menu selection.

Numeric Input

You can enter numeric values by using either the numeric keypad or the general purpose knob. If the side menu item displays a value, you can alter this value using the general purpose knob or numeric buttons. See Figure 2–12.

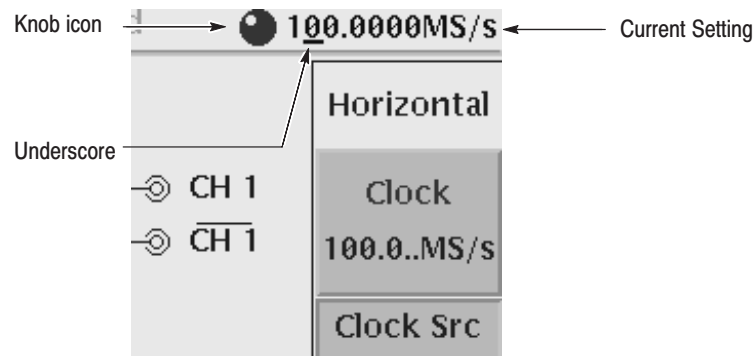

Figure 2–12: Knob icon displayed in Status Display area

The General Purpose Knob. A knob icon with a numeric value that includes an underscore character indicates that you can change the value at the underscore location by using the general purpose knob or keypad buttons. By default, the underscore character is positioned under the digit specified depending on the parameters. You can only change the value represented by the digits at and to the left of the underscore. Use the ◀ and ▶ arrow buttons to move the underscore to the desired position, and then turn the general purpose knob to change the value.

If the numeric value has the knob icon but does not have the underscore, then turning the general purpose knob cycles through a predefined set of values.

When using the general purpose knob, values that you change in side menus and menu screens take effect immediately. Values in pop-up menus are not effective until you push the **OK** side button or the **ENTER** front-panel button.

The Numeric Keypad. Figure 2–13 shows the numeric keypad and descriptions of the button operations.

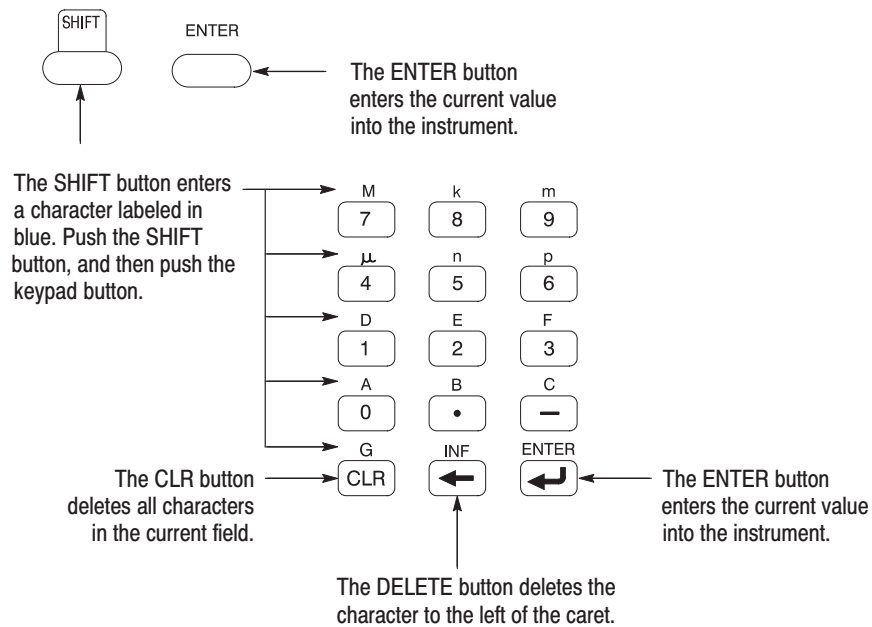

Figure 2-13: Keypad buttons

The **G**, **M**, **k**, **m**, **μ**, **n**, and **p** are unit buttons. The **A**, **B**, **C**, **D**, **E**, and **F** buttons are used for entering hexadecimal values.

To use the numeric keypad to enter a value, position the caret to where you want to change a value, and then push a keypad button. If you want to enter a unit value labeled in blue just above each numeric button, push or hold down the **SHIFT** button, and then push the corresponding numeric button.

- The current unit is always kept if you do not change the unit. For example, if you want to change from 100 MHz to 200 MHz, you can push **2**, **0**, **0**, and **ENTER** button.
- Push numeric buttons and unit button to enter the specific unit. For example, if you want to change from 100 MS/s to 200 kS/s, you can push **2**, **0**, **0**, and **k** (**SHIFT** + **8**).
- The default time unit, **s** or the default voltage unit, **v** is selected if you enter numeric value, the **SHIFT** button and then the **ENTER** button. For example, if you want to change from 100 ms to 1 s, you can push **1**, the **SHIFT** button and then the **ENTER** button.

To enter or change more than one character, move the caret to the next position to change. When you are done entering values, push the **ENTER** button to confirm the changes and enter them into the instrument. For example, to enter 200.5 μs, push **2**, **0**, **0**, **.**, **5**, **μ** (**SHIFT** + **4**), and **ENTER**.

When you enter a value larger than the maximum value in the range for the parameter, the parameter will be set to the maximum value. When you enter a value smaller than the minimum value, the minimum value will be set in the parameter. To set to the maximum or minimum value, enter a larger value or smaller value. This is useful when you do not know the range that can be set.

Note that the current unit is always kept when you just use the **ENTER** after entering digits. For example, suppose that the Clock is currently set to 100.0 MS/s. When you press the **5**, **0** and **ENTER** buttons in this order, the Clock will be set to 50.0 MS/s. To set the Clock to 500 kS/s, press **0**, **,**, **5** and **ENTER** buttons, or **5**, **0**, **0**, **SHIFT**, and **8** buttons in this order.

Text Input

When you need to assign a name to a waveform file or equation, or a IP address to the instrument, the instrument displays a text dialog box. See Figure 2–14. The text field is where you enter or change an existing character string. The character palette is where you select alphanumeric characters to insert into the text field. You can also select equation or file names from the name list to insert into the text field.

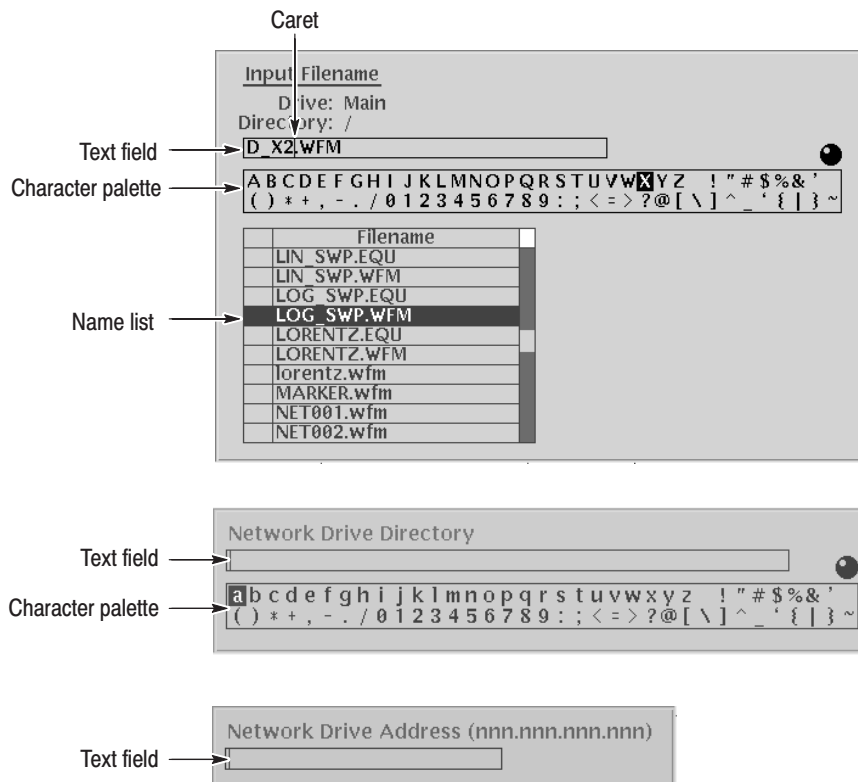

Figure 2–14: Three types of Input text dialog boxes

To select a character from the character palette, use the general purpose knob to highlight a character, and then push **ENTER** to insert the character into the text field. Repeat this step until you have entered all the characters in the text field. By default, the character palette is selected. To select text from a file name list, use the ▲ and ▼ arrow buttons to move the knob icon to the file name list. Table 2–6 describes all the controls you can use for entering and editing text.

File Name Input

You need to check that the character palette is highlighted and also that the general purpose knob is displayed. You cannot select characters if the character palette is not highlighted. If the character palette is not highlighted, use the ▲ and ▼ arrow buttons to make the character palette highlighted.

Do the following steps to input the file name.

1. Push the ▲ and ▼ arrow buttons to move the caret in the text field.
2. Use the general purpose knob to select the character.
3. Push the **ENTER** button or ↵ button to insert the selected character at the caret position.

Repeat steps 1 through step 3 to input the file name.

The file list of the current directory is displayed under the character palette. In default, the file is stored in the current directory. If you want to store the file in another directory, use the general purpose knob to move the directory. If you want to store the file in another drive, push **DRIVE...** (side menu) to change the drive. You can select the **Up Level** or **Down Level** (side menu) to move to another directory.

4. Push **DRIVE...** (side menu) if you want to change the drive. Use the general purpose knob or ▲ and ▼ arrow buttons to select the drive in the select drive dialog box and push **OK** (side menu).
5. Push **Up Level** (side menu) to move up a directory. You cannot move up a directory if you are at the highest directory level.
6. Press ▲ and ▼ arrow buttons, to activate the file list if you want to move to a selected file in the directory.
7. Use the general purpose knob to select the directory, and push **Down Level** (side menu).
8. Press ▲ and ▼ arrow button to activate the text field and input the file name.

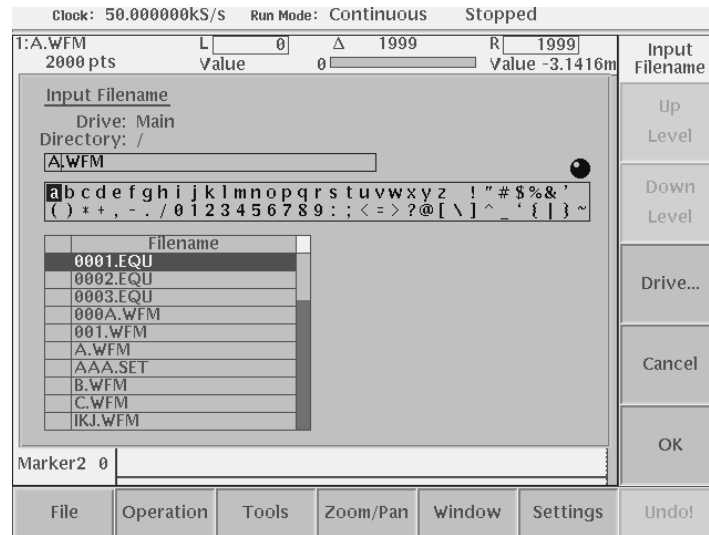

Figure 2-15: Input Filename dialog box

Table 2-6: Text input button functions

| Control | Description |
|-----------------------|---|
| General purpose knob | Selects the character to insert into the text field. |
| ◀ and ▶ arrow buttons | Moves the character insertion caret left or right in the text field. |
| ⬇ and ⬆ arrow buttons | Changes the knob selection area the character palette and the filename list. |
| ENTER button | Inserts the selected character or character string into the text field. |
| ← button | Deletes one character to the left of the caret. |
| CLR button | Clears the entire text field. |
| Numeric buttons | Enters numeric characters into the text field. |
| SHIFT button | Enters a selected character in upper case. When you push the SHIFT button, the SHIFT LED lights. When the dialog box disappears, the SHIFT LED also goes off. |

Shortcut Controls

Figure 2–16 shows the shortcut buttons and knobs that control specific instrument setup parameters. Using the shortcut controls lets you adjust the output setup parameters even while you are displaying another menu. Table 2–7 describes the shortcut controls.

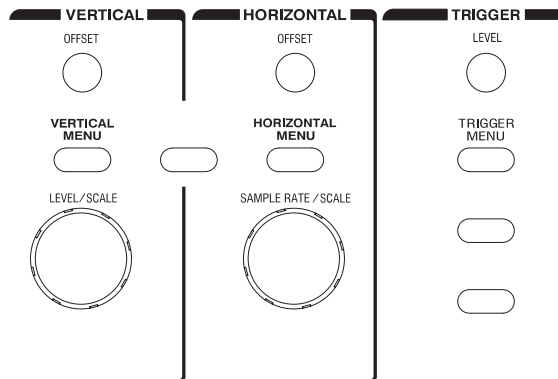

Figure 2–16: Shortcut controls

Table 2–7: Shortcut controls







| Controls | Description |
|---|--|
| VERTICAL | |
|  | Displays the Vertical side menu. This is the same operation as selecting SETUP (front)→ Vertical (bottom). |
|  | Adjusts the vertical offset parameters. This is the same as selecting SETUP (front)→ Vertical (bottom)→ Offset (side), and then turning the general purpose knob. |
|  | Adjusts the amplitude parameters. This is the same as selecting SETUP (front)→ Vertical (bottom)→ Amplitude (side), and then turning the general purpose knob. |
| HORIZONTAL | |
|  | Displays the Horizontal side menu. This is the same as selecting SETUP (front)→ Horizontal (bottom). |
|  | Adjusts the clock setting. This is the same as selecting SETUP (front)→ Horizontal (bottom)→ Clock (side), and then turning the general purpose knob. |

Table 2-7: Shortcut controls (cont.)

| Controls | Description |
|--|---|
| TRIGGER  | Displays the Trigger side menu. This is the same as selecting SETUP (front)→ Trigger (bottom). |
|  | Adjusts the trigger level setting. This is the same as selecting SETUP (front)→ Trigger (bottom)→ Level (side), and then turning the general purpose knob. |

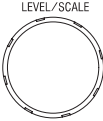
File management

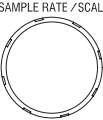
This section is an overview of the file operations for doing file management tasks.

Name and location

File Type Suffixs. The AWG400-Series Arbitrary Waveform Generator uses numerous file formats to hold different types of data. These file types are listed in Table 2-8. Note that the instrument checks the file format and processes the file based on its content, regardless of the file suffix.

Table 2-8: AWG400-Series Arbitrary Waveform Generator file types

| | |
|---------------|---|
| Waveform file | .wfm or .WFM file suffix is used. Contains waveform data. All signal data must be in waveform format before it can be output. Created with the waveform editor, by compiling an equation file, or when importing waveforms from external equipment, and created waveform data by application. |
| Pattern file | .pat or .PAT file suffix is used. Contains pattern data. Created with the pattern editor. |
| Sequence file | .seq or .SEQ file suffix is used. Contains waveform sequence and trigger data. Created with the sequence editor. |
| Equation file | .equ or .EQU file suffix is used. Contains equations that describe a waveform. Created with the equation/text editor. |
| Text file | .txt or .TXT file suffix is used. Contains ASCII text. Created with the equation/text editor. And setting parameter file of APPL Digital Modulation. |
| Setup file | .set or .SET file suffix is used. Contains instrument setup and configuration data of both AWG and FG mode. Created from the SETUP menu. |

Locating Files. There are three locations for storing waveform data on the AWG400-Series Arbitrary Waveform Generator. Data can be stored on the instrument hard disk drive, the instrument floppy disk drive, or a remote storage

device accessible through the Ethernet interface. If the file you want to load is not on the current drive, use the SETUP menu main screen **Drive** and **Directory** bottom menu buttons to open side menus that let you change the current drive location. Table 2–9 describes the Drive and Directory bottom buttons.

Table 2–9: Drive and Directory menus

| Bottom menu | Side menu | Description | |
|-------------|----------------|--|--|
| Drive | Main | Changes the instrument current drive. To select a drive, push the appropriate side menu button. Note that there must be a floppy disk inserted in the instrument floppy disk drive to select the floppy drive. Note that the label Net1, Net2 and Net3 vary depending on the net name settings in the UTILITY menu. | |
| | Floppy | | |
| | Net1 | | |
| | Net2 | | |
| Directory | Net3 | Moves up a directory level. | |
| | Up Level | | |
| | Down Level | | Moves down a directory level. To move down a directory level, select a directory name in the pop-up list, and then push the Down Level side button. The filename list changes to show the contents of the directory. |
| | Make Directory | | Creates a directory at the current level. To create a directory, push the Make Directory side button to display the Input New Directory Name dialog box. Enter the directory name in the name field, then push the OK side button. The instrument creates the new directory. |
| | Archive | | Creates a new file (.tar format) for archive from selected directory. The archived file keeps hierarchic structure. |
| | Extract | Restore the archived file (.tar) to the current directory. | |

NOTE. In the following procedures, you may have to push the *EDIT* button twice to quit the editor. When the instrument does not display the file list, try to push the *EDIT* button again. If you are prompted, refer to Saving Files on page 2–33.

Copying Files

You can copy the files in double windows or in single windows. In double window, the selected file in the active window can be copied into the other by window using the Copy button.

Copying files in double windows. Do the following steps to copy the files selected in the active window:

1. Push **EDIT** (front) button and select the file to copy.
2. Push **Window** (bottom)→**Window** (side) to select **Double**.

Two file windows are displayed.

3. Push **Select** (side) to select the active window.
4. Push **Directory** (bottom)→**Up Level, Down Level, or Make Directory** (side) to select the destination.
5. Push **Select** (side) to activate the window in which the file is in to be copied and then select the file.
6. Push **File** (bottom)→**Copy** (side) to copy the file to the destination as the same file name.

If the directory name is the same as the destination directory name, you will be asked to confirm that you want to overwrite the file.

Copying files in single window. Do the following steps to copy the files selected in single window.

1. Push **EDIT** (front) button, and select the file to copy.
2. Push **File** (bottom)→**Copy** (side), and select the file name and destination.
3. Push **OK** (side) to copy the file.

The file is copied and renamed.

NOTE. You can copy a file or all files in another way. Refer to Double Windows on page 2–36 for those methods.

You can also move a file or all files. Refer to Double Windows on page 2–36 for those methods.

Moving Files

You can move the file in double windows. Do the following steps to move the file:

1. Push **EDIT** (front) button, and select the file to copy.
2. Push **Window** (bottom)→**Window** (side) to select **Double**.
Two file windows are displayed.
3. Push **Select** (side) to select the active window.
4. Push **Directory** (bottom)→**Up Level, Down Level, or Make Directory** (side) to select the destination.
5. Push **Select** (side) to activate the window in which the file is in to be moved and then select the file.
6. Push **File** (bottom)→**Move** (side) to move the file to the destination.

If the directory name is the same as the destination directory name, you will be asked to confirm that you want to overwrite the file.

Renaming Files

Renaming files is done from the EDIT menu screen. Do the following steps to rename a file:

1. Push **EDIT** (front).

The instrument displays the file list.

2. Select the file to rename.
3. Push **File** (bottom)→**Rename** (side).
4. Enter the new name for the file in the file name field.
5. Push **OK** (side).

The file is renamed.

Deleting Files

You can delete a file or directory at the location of the cursor. Do the following steps to delete a file:

NOTE. *You cannot delete a file or directory if the file or directory is set to 'read only'. Also, you cannot delete a directory if the directory is not empty.*

1. Push **EDIT** (front).

The instrument displays the file list.

2. Select the file to delete.
3. Push **File** (bottom)→**Delete** (side). The instrument displays a message box asking you to confirm deleting the file.
4. Push **OK** (side) to delete the file or **Cancel** to cancel the operation and keep the file.

You can also delete all files on the current drive and directory by doing the following steps:

1. Push **EDIT** (front)→**File** (bottom)→**Delete All** (side).

The instrument displays a message box asking you to confirm deleting all files.

2. Push **OK** (side) to delete all files or **Cancel** to cancel the operation and keep all files.

Read Only Attribute

You can change the read only or read/write attributes on a file. Do the following steps to change the file attribute:

1. Push **EDIT** (front).
The instrument displays the file list.
2. Select the file to change the attribute.
3. Push **File** (bottom)→**Attribute xxxx** (side).

The **xxxx** is the **Read/Write** or **Read Only** attribute of the selected file. Pushing this side button immediately changes the file attribute.

The file with a read only attribute is marked by , and the directory by . See Figure 2–17.

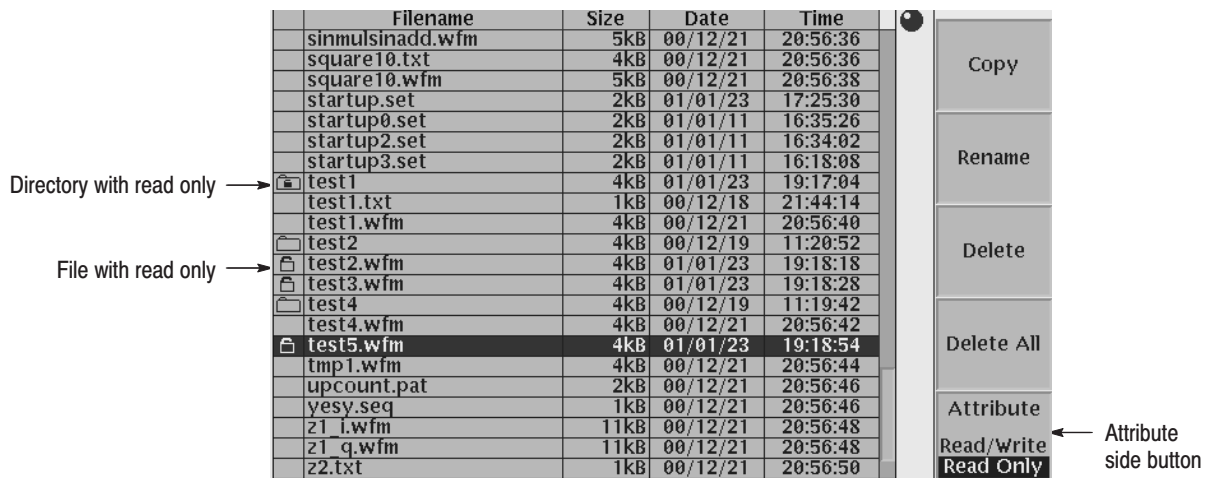

Figure 2–17: Files and directories with read only attribute

Saving Files

File saving is done from within each editor screen. You have the choice of saving your waveform data to the current file name or to a new file name. To save a waveform to its current file name, push **File** (bottom)→**Save** (pop-up)→**OK** (side).

If you are saving a waveform for the first time, the instrument opens the Input Filename dialog box, shown in Figure 2–18. Use this dialog box to enter a file name. If necessary, you can select a different storage media or directory by pushing the **Drive...** side menu button. When you are done entering the file name, push the **OK** side button or the **ENTER** front-panel button to close the dialog box and save the file.

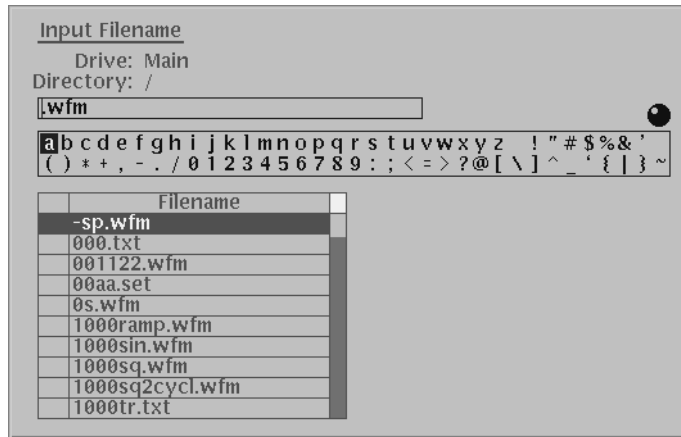

Figure 2-18: Input Filename dialog box

NOTE. When you exit an editor without saving edited data, the instrument displays the message **Save the changes you made?** Push the **Yes** side button to save the waveform data.

To save waveform data to a new file name, push **File** (bottom)→**Save As** (pop-up)→**OK** (side). The instrument opens the Input Filename dialog box, shown in Figure 2-18. Use this dialog box to enter a file name. If necessary, you can select a storage media or directory by pushing the **Drive...** side menu button. When you are done entering the file name, push the **ENTER** front-panel button to close the dialog box and save the file.

If you are saving a file with a record length larger than 64 data points, the instrument needs to adjust the record length to meet internal memory record length requirements. The instrument displays one of the messages shown in Table 2-10. Select one of the messages, and push the **OK** side button to accept the recommended change or cancel the save and then edit the file to satisfy the data record length requirements.

Table 2-10: Waveform record length adjustment messages

| Message | Description |
|----------------|---|
| Leave as it is | The data is saved, as it is, without making changes. The instrument will display an error message if you try to load a file that does not meet the instrument waveform constraints. |
| Append 0 | With Level-0 data added after the data, a file with a data length meeting the requirements is created. |
| Expand | With the waveform data expanded, a file with a data length meeting the requirements is created. |

Table 2-10: Waveform record length adjustment messages (cont.)

| Message | Description |
|-------------------|--|
| Expand with Clock | With the waveform data expanded, a file with a data length meeting the requirements is created. In addition, the clock frequency increases without change in scaling factor. The settings are saved in the file. |
| Repeat | With repetitions of the original data linked, a file with a data length meeting the requirements is created. |

Archive, Extract To archive or extract files, do the following steps.

Archive. When you select Directory in the file list, you can make archives for all the files in the directory and subdirectory.

1. Push **EDIT** (front).

The instrument displays the file list.

2. Select the file to make archive files.
3. Push **Directory** (bottom)→**Archive** (side).

The instrument displays the Input archive name dialog box. By default, the name of <directory name>.tar is automatically assigned. If necessary, you can change the name.

4. Push **OK** button, and the archive file will be created in the current directory.

Extract. The archived file is extracted (restored) to the current directory. If the directory already exists, the existing file will be overwritten.

1. Push **EDIT** (front).

The instrument displays the file list.

2. Select the file to extract.
3. Push **Directory** (bottom)→**Extract** (side).

The instrument extracts the archived files and directories to current directory.

Remote computer archive operation. AWG400-Series uses .tar format files. Use the **tar** command when you archive with a remote computer environment. If you are PC user, use **tar** format archive tool.

The following list describes some restrictions on archive and extract operation.

- Blocking factor is 20.

- The file name including the file path in the directory is up to 100.
- The depth of directory hierarchy is up to 16.

Use the following command to make archive file:

```
tar [-] cvf <tar file name> <file name or directory name>
```

Use the following command to extract archive file:

```
tar [-] xvf <tar file name>
```

Double Windows

When the **Window** bottom menu button is displayed, you can divide the file list in the Edit Screen into two lists as shown in Figure 2–19. This function is called Double Windows.



Figure 2–19: Double Windows

In Double Windows, for example, you can display the file list of the hard disk and also the list of the floppy disk, or the file lists of two different directories. All the functions invoked from the bottom menu buttons operate the same in single window except for the **File** function.

The most important functions to be used in two file lists displayed at the same time are Copy and Move file operations. These operations are discussed in *Window Operation* as follows.

Window Operation

The windows are named Upper and Lower as indicated in Figure 2–19. You should select a window for operation.

When you push **EDIT** (front) → **Window** (bottom), the Window side button appears. Push the **Window** side button to select **Double**. Double windows are displayed. Push the **Window** side button once more to select **Single**. The display returns to the single file list.

When you display the double windows, the **Select** side button will be available. Push the **Select** side button to select **Upper** for file operation in the upper file list window. Push the **Select** side button once more to select **Lower** for file operation in the lower file list window.

Operation in Double Windows

The most useful functions to be used in the double windows may be those invoked from the **File** bottom button. The functions available in the **File** bottom button are described in Table 2–11.

Table 2–11: File operation in double windows

| Operation | Description |
|-----------|--|
| Copy | Copies a file selected in a selected file list window into the destination specified in the other file list window. You cannot select the directory. |
| Copy All | Copies all files in a selected file list window into the destination specified in the other file list window. You cannot copy the directory or directory structure. |
| Move | Moves a file selected in a selected file list window into the destination specified in the other file list window. You cannot select the directory. |
| Move All | Moves all files in a selected file list window into the destination specified in the other file list window. You cannot move the directory or directory structure. |

NOTE. You cannot use the **Rename**, **Delete**, **Delete All**, and **Attribute** side buttons unless you display the single file list window.

In copy or move operations, when files with the same file name exist in the destination, the message *Overwrite existing file <filename>* appears. At the same time, the **Cancel**, **No**, **Yes to All** and **Yes** side buttons appear. Press any of these side buttons to proceed with the operation. See Figure 2–20 and Table 2–12.

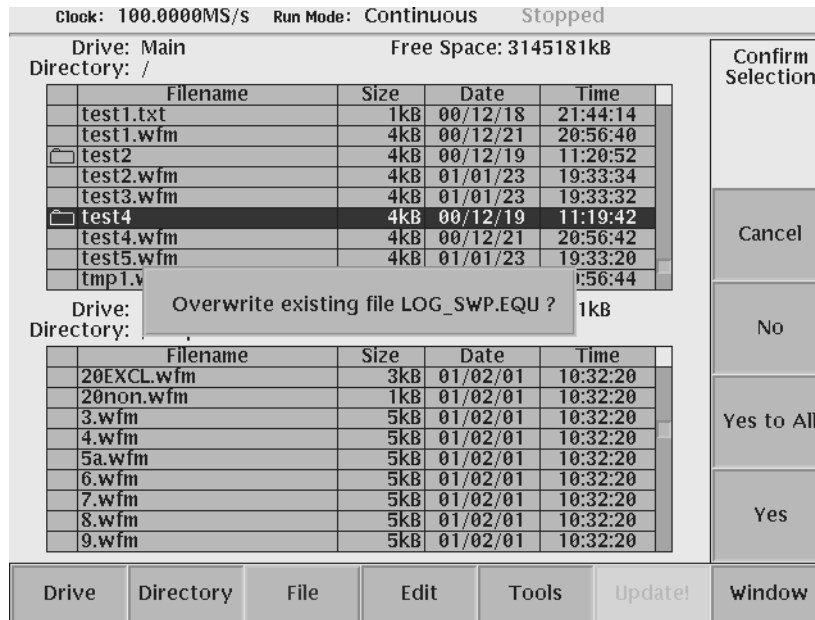

Figure 2-20: Overwrite confirmation

Table 2-12: Confirmation selection for copy-all and move-all operations

| Side menu | Description |
|------------|---|
| Cancel | Cancels and stops the copy or move operation. |
| No | Skips the copy or move operation for the file indicated in the message. |
| Yes to All | Overwrites all the files without displaying any messages until the operation is finished. |
| Yes | Overwrites the file indicated in the message and proceeds with the operation. |

You cannot copy or move the directory. In copy-all or move-all operation, the message *Directory cannot be copied* appears if you try to move or copy a directory. Press the **OK** side button to confirm and proceed with the operation.

Quick View

Before loading or handling a file, you sometimes want to look at the content of a file to confirm the operation. The quick view function displays the view window and allows you to view a waveform or pattern file selected in a file list. This function is always available when a file list is displayed on the screen. See Figure 2-21.

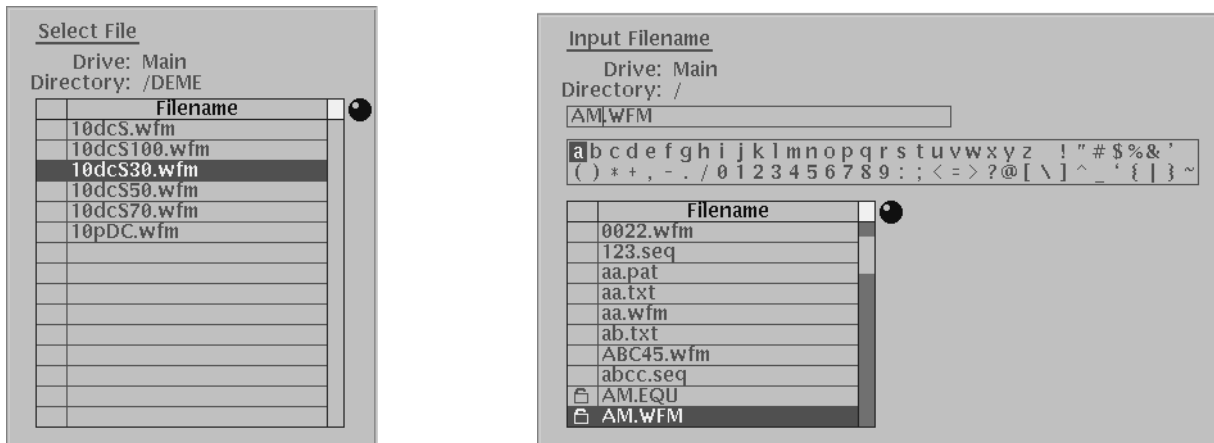

Figure 2-21: File list window examples in which Quick View is available

Select a file from the file list window using the general purpose knob. Press the **SHIFT** and **ENTER** front-panel buttons simultaneously. The view window displaying the waveform or pattern appears as shown in Figure 2-22.

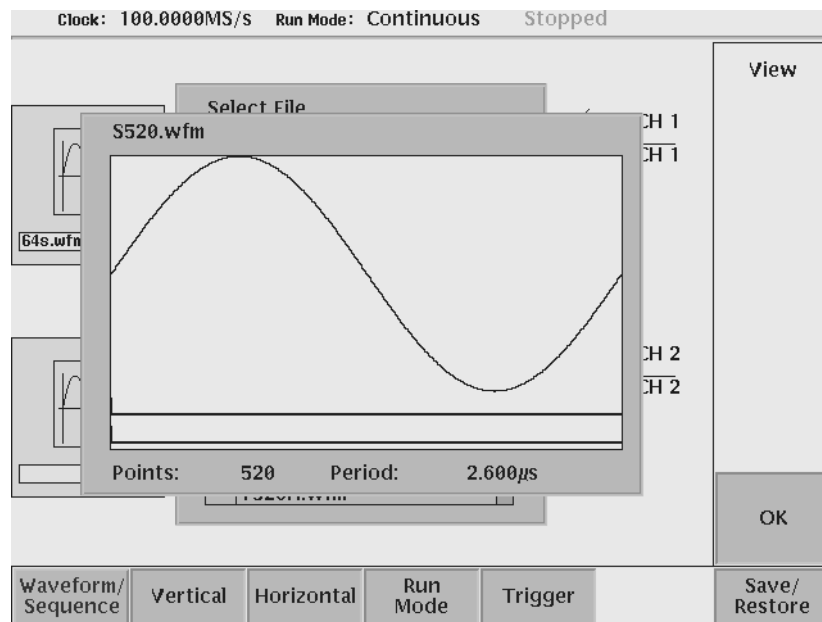

Figure 2-22: Viewing a file by Quick View function

Push the **OK** side menu button to close the view window. You cannot view files other than waveform or pattern in this function.

This function is always available when a file list window or file list dialog box is displayed on the screen.

Setup Overview

The Setup screen is where you load and set up the waveform for output. This section gives you an overview of the Setup screen, how to load a file, how to set the signal output parameters, and how to enable signal output. Refer to *The Setup Menu Screen* in the *Reference* section of the user manual for more information.

Main Setup Screen

Push the **SETUP** front-panel button to display the main Setup screen. See Figure 2–23. Table 2–13 describes the screen waveform parameter icons. Table 2–14 lists the bottom menu functions.

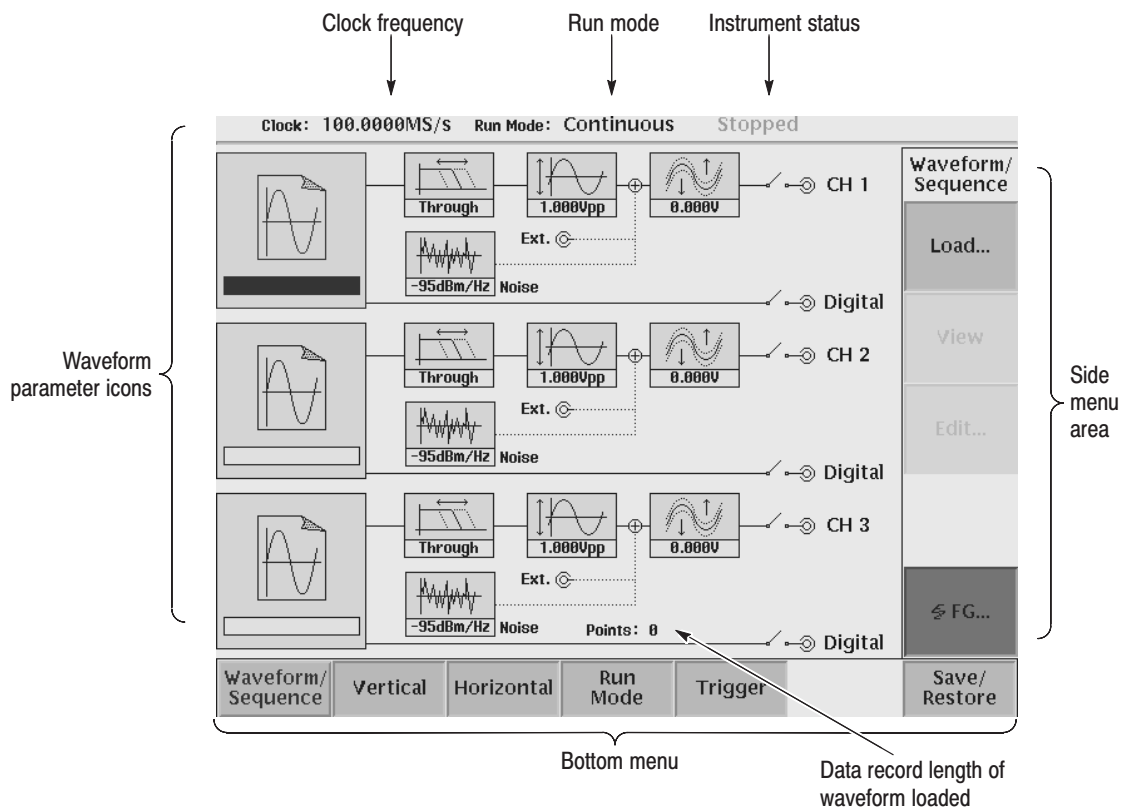

Figure 2–23: Main Setup screen (AWG430)

Table 2-13: Setup screen parameter icons



| Icon | Description | Icon | Description |
|---|--|---|---|
|  | Displays the file name of the waveform, pattern, or sequence file loaded for output. Note: Use the View button to display the loaded waveform. |  | Displays the noise signal level added. |
|  | Displays the bandpass filter setting through which the waveform is passed. |  | Indicates that the channel output is enabled or disabled. If the switch is shown open, that channel output is disabled. |
|  | Displays the peak-to-peak signal amplitude setting. |  | Indicates that the digital output is enabled or disabled. If the switch is shown open, that digital output is disabled. |
|  | Displays the signal offset setting. |  | Displays the external input added. |

Table 2-14: Setup bottom menu buttons

| Bottom menu button | Description |
|--------------------|---|
| Waveform/Sequence | Displays the side menu for loading, viewing, and editing waveform files. |
| Vertical | Displays the Vertical side menu for setting waveform peak-to-peak amplitude, offset, bandpass filter, and other output parameters. |
| Horizontal | Displays the Horizontal side menu for setting the clock source, clock frequency, clock reference, and channel skew parameters. |
| Run Mode | Displays the Run Mode side menu for setting the instrument run mode. Refer to <i>Run Modes</i> on page 3-5 for an explanation of the different run modes. |
| Trigger | Displays the Trigger side menu for setting trigger source, slope, level, external trigger impedance, and interval parameters. |
| Save/Restore | Displays the Save/Restore side menu to save and restore setup output parameters. |

Composition and Setup of Output Channel

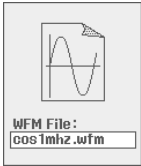
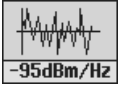
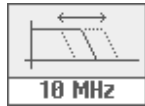
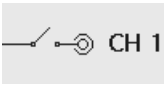
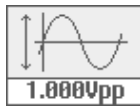
Use the Setup menu to set up parameters for each channel as well as the instrument.

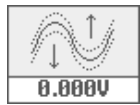
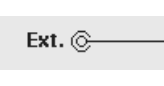
Set up the file for load, amplitude, and the run mode for each channel. Set up the Horizontal, Run Mode, and Trigger for the instrument.

Loading a Waveform File to Output

Do the following steps to load a waveform file into the Setup screen:

1. Push the **Waveform/Sequence** bottom menu button.

This opens the Waveform/Sequence side menu.

2. Push the **Load...** side button. The instrument opens the Select File list as shown in Figure 2–24.

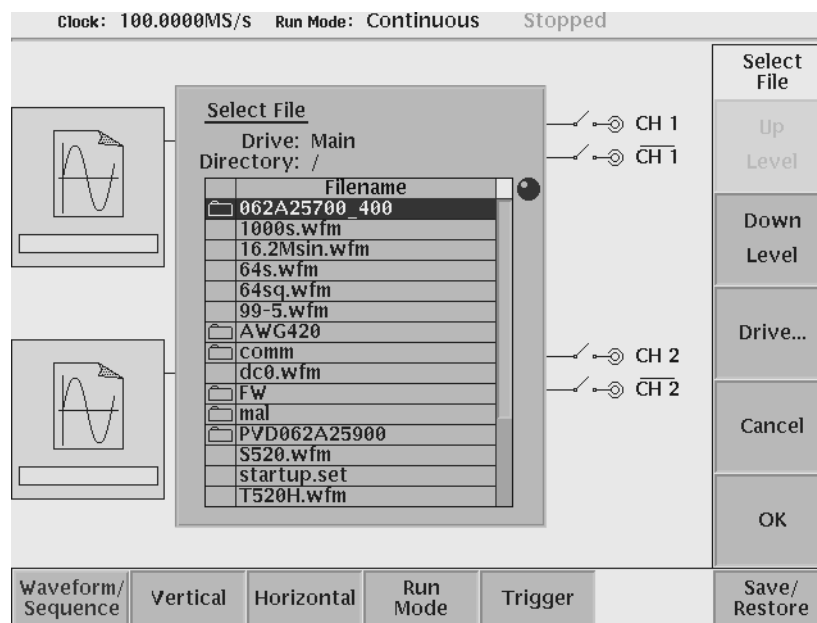

Figure 2–24: Setup Waveform/Sequence menu

3. Use the general purpose knob or arrow buttons to select the file name to load. If the file that you want to load is located in a different drive or directory, use the side menu buttons to change the current drive or directing.
4. Push the **ENTER** front-panel button or the **OK** side button. The instrument loads the file and displays the file name in the selected channel file icon. Push the **Cancel** side button to exit the file load process.

The procedures above explain how to load a waveform or pattern into the waveform memory, and/or a sequence file into the sequence memory, which will be scanned to output. The waveform memory, sequence memory, and the edit

buffer are completely independent. So, you can edit a waveform, pattern, sequence, or equation/text while outputting another waveform or sequence.

However, when you push **SETUP** (front-panel)→**Waveform/Sequence** (bottom)→**Edit** (side) to copy the waveform in the waveform memory to the edit buffer, you must save the currently edited waveform, pattern, sequence, or equation/text into a file.

You can enter into the QUICK EDIT mode only from the waveform editor. When you enter into the quick edit mode, the instrument copies the data in the edit buffer into the undo buffer. All the changes that you make immediately reflect to the data in the edit buffer, and also to the data in the waveform memory if that data is being loaded to output.

Before loading, you can view a waveform or pattern. Refer to *Quick View* on page 2–38 for more detail.

Viewing a Waveform

To view the loaded waveform file, push the **View** side menu button. The instrument opens a window on the screen that displays the waveform, as shown in Figure 2–25. Push the **OK** side menu button or **ENTER** front-panel button to close the view window.

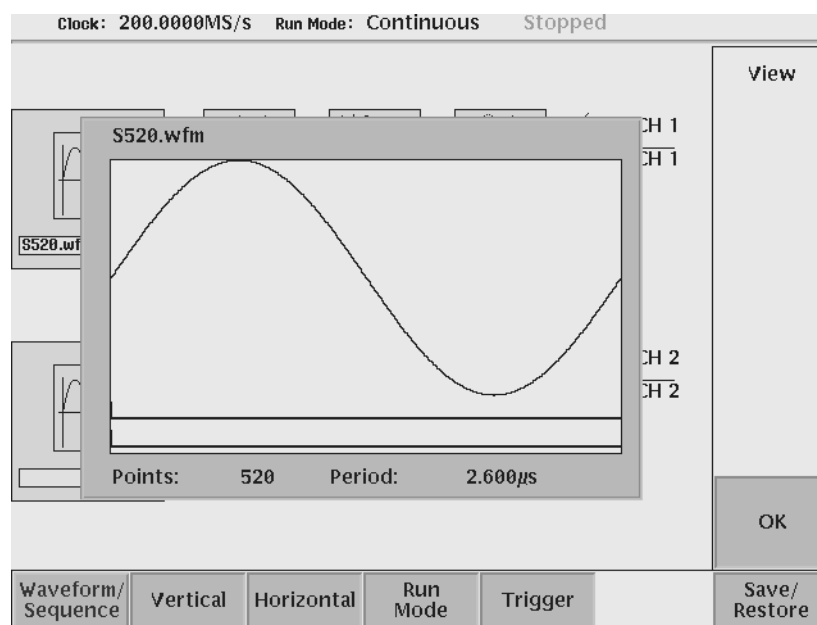

Figure 2–25: Viewing a file in the Setup screen

Note that the view function always displays the waveform in the file that you specified, but not the waveform in the waveform memory. Even when you change the waveform with the editor and update the waveform memory, the view

function still displays the waveform before the update unless you do not save the file.

Setting Waveform Output Parameters

The Setup side menus provide commands for setting and adjusting waveform output parameters. The steps for setting output parameters are discussed in detail in the *Reference* section of the user manual. Table 2–15 provides an overview of the Setup side menu operations.

Table 2–15: Setup output parameter operations

| Bottom button | Side button | Description |
|-----------------------|-------------|--|
| Waveform/ Sequence | Load... | Displays the Select File dialog box that lists files in the current drive and directory. Select a file to load or use the side menu buttons to change drives and/or directories. |
| | View | Displays the loaded file in a window. Push the OK side menu button to close the view window. |
| | Edit... | Opens the appropriate editor for the loaded file. |
| Vertical | Filter | Selects bandpass filter to insert into signal path. Filter values are through (no filter), 1 MHz, 5 MHz, 20 MHz, and 50 MHz. Use the general purpose knob to enter new values. |
| | Amplitude | Sets the signal peak-to-peak amplitude in increments of 0.001 V. The maximum value is 2 V _{p-p} (5 V _{p-p} with Option 05) in normal mode and 0.5 V _{p-p} in direct mode. Use the general purpose knob or the keypad to enter new values. |
| | Offset | Sets the signal offset value in increments of 0.001 V. The offset voltage range is ±1 V. Use the general purpose knob or the keypad to enter new values. |
| | Add... | Adds the internal noise signal and/or external input signal to a waveform. You can set the range of the internal noise generator level within the limits of -140 to -95 dBm/Hz (-130 to -95 dBm/Hz with Option 05). |
| | Output | Select to connect the DAC output directly to the channel connector. |
| Horizontal | Clock | Sets the clock sample rate from 10 kS/s to 200 MS/s. |
| | Clock Src | Sets the clock source to either Internal or External. When set to Internal, 10 MHz internal reference clock used. When set to External, a valid external clock signal is DC to 200 MHz with a voltage level of 0.4 V _{p-p} to ±2 V. |
| | Clock Ref | Sets the reference clock source to either Internal or External. A valid external clock signal is 10 MHz ±0.1 MHz with a voltage level of 0.2 V to 3.0 V _{p-p} . |
| | Skew... | Sets the skew between Ch1, Ch2, and CH3 within -2.52 ns to 2.52 ns in 70 ps steps. |

Table 2-15: Setup output parameter operations (cont.)

| Bottom button | Side button | Description |
|---------------|--|---|
| Run Mode | Continuous Triggered Gated Enhanced | Displays the Run Mode side menu for setting the instrument run mode. Refer to The <i>Run Mode Menu</i> section on page 3-5 for an explanation of the different run modes. |
| Trigger | Source | Sets trigger source to Internal or External. If External is selected, only the interval side menu item is selectable. |
| | Slope | Sets the trigger slope or gate polarity to Positive or Negative. |
| | Level | Sets the trigger signal level. The trigger level range is ± 5.0 V in 0.1 V increments. |
| | Impedance | Sets the external trigger input line impedance to either 50 Ω or 1 k Ω . |
| | Interval | Sets trigger interval from 1.0 μ s to 10.0 s. |
| Save/Restore | Save Setup | Saves the setup parameters set by SETUP window as a setup file. |
| | Restore Setup | Restores a setup file. |

Outputting a Waveform

To output a loaded waveform, push the **CH (1, 2, or 3) OUT** and/or **CH (1, 2, or 3)_OUT** front-panel button(s), and then the **RUN** front-panel button. The LEDs near each button light to indicate they are enabled. The instrument outputs the waveform(s) depending on the Run mode. You can turn either or both channel outputs on or off while the instrument is running by pushing the **CH (1, 2, or 3) OUT** or **CH (1, 2, or 3) OUT** buttons. To stop the waveform output, push the **RUN** button so that the LED turns off.

Saving and Restoring Setup Parameters

The waveform or pattern file contains only the waveform and clock information. When you load a waveform or pattern file, the output signal will use the current instrument setup parameters.

To save you from doing a manual setup procedure each time you load a waveform, the AWG400-Series Arbitrary Waveform Generator lets you save setup parameters into a setup file. You can then restore the saved settings for use with waveforms.

The setup parameters when saving is included in a setup file. When a setup file is restored, settings in both AWG mode and FG mode will replace the contents of a setup file.

Do the following steps to save the current setup parameters:

1. Push **SETUP** (front)→**Save/Restore** (bottom)→**Save Setup** (side).

The Select Setup Filename dialog box appears.

2. Enter a setup file name.

The setup file name has .set suffix as part of the file name.

3. Push the **OK** side button.

The setup information is saved to the designated file.

Do the following steps to restore the setup parameters from a file:

1. Select **SETUP** (front)→**Save/Restore** (bottom)→**Restore Setup** (side).

2. Enter or select the setup file name to load.

3. Push the **OK** side button to load the file and restore the setup parameters, or push the **Cancel** side button to exit the restore process without loading the setup file.

Theory of Operation

This section presents an overview of the AWG400-Series hardware, data structures, and operating modes to allow you to take full advantage of the AWG400-Series.

Block Diagrams Figure 3–1 shows the main hardware blocks that make up the AWG400-Series, respectively. This section describes these hardware blocks to provide the background knowledge necessary to use the instrument effectively.

CPU The CPU Unit block controls the instrument the CPU Unit block contains the Solid Disk, RAM, HDD, and external interfaces blocks.

The external interface addresses remote control via the GPIB, floppy disk connection, 100/10BASE-T Ethernet connection, user interface through the display screen and the front-panel, and so on.

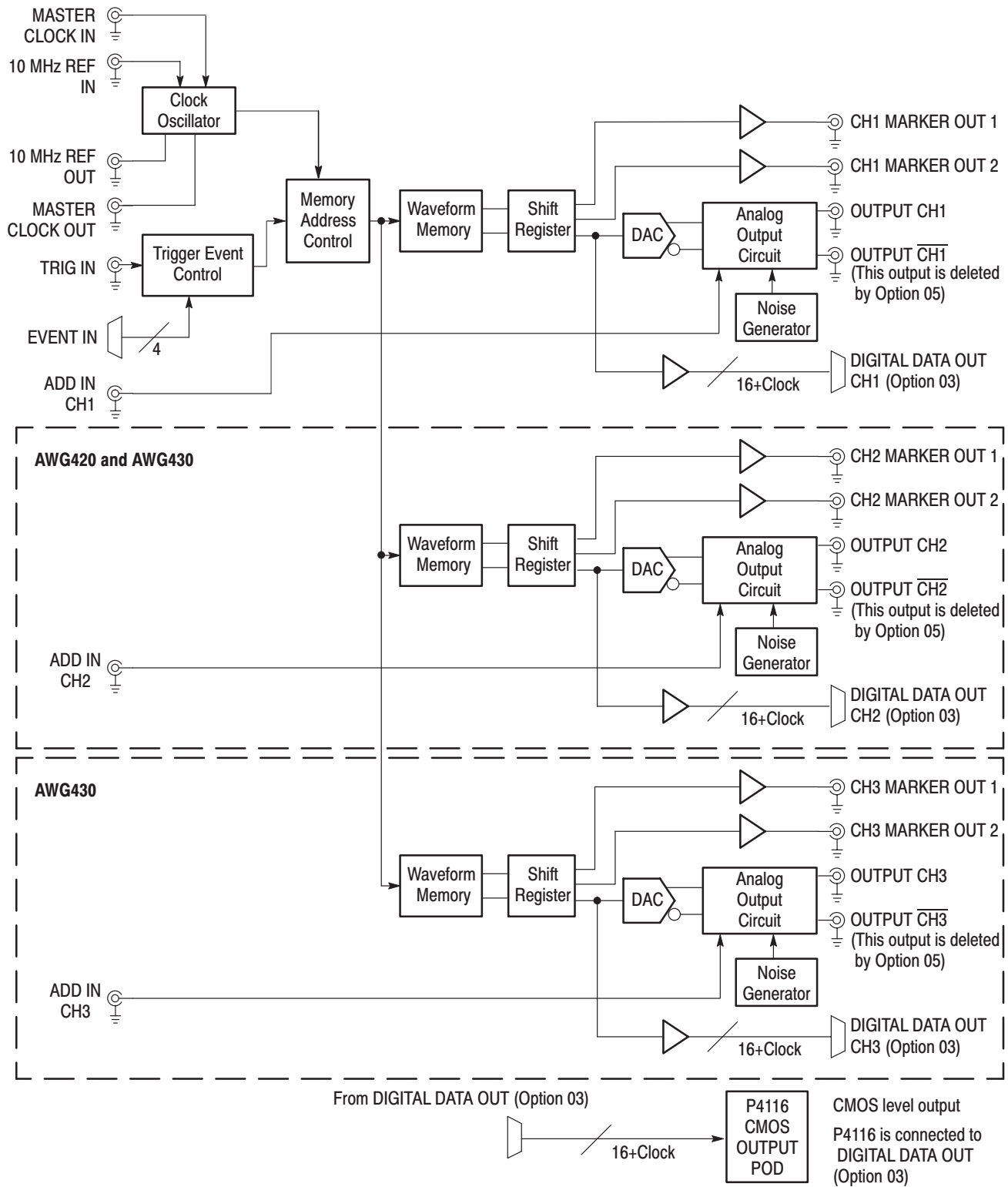

Figure 3-1: AWG400-Series block diagram

Clock Oscillator

The internal clock is derived from the reference clock oscillator or from the external reference clock connected to the 10MHz REF IN connector, which uses VCO, DDS (direct digital synthesis), and a PLL circuit. A high-quality clock with a frequency of 10 kHz to 200 MHz, a resolution of 7 digits, and a low-jitter are provided using the divider. Figure 3–2 shows the clock oscillator configuration.

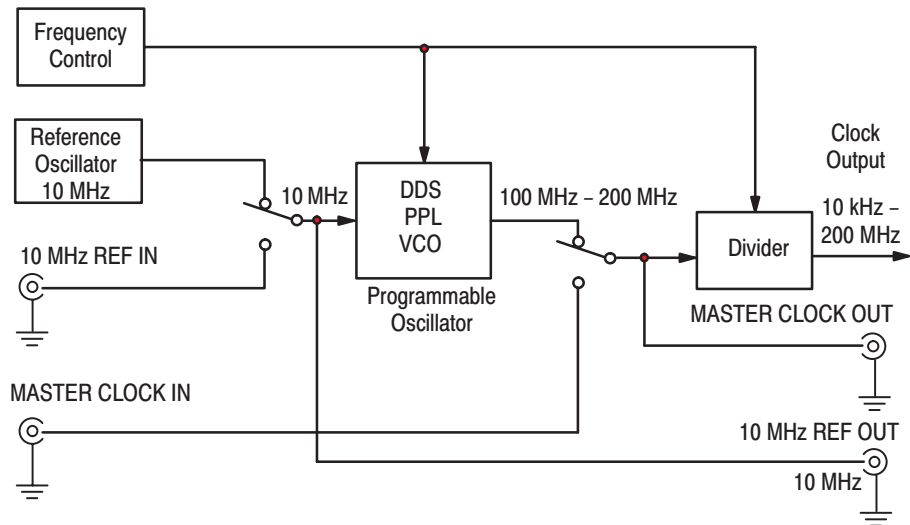

Figure 3–2: Clock oscillator configuration

10 MHz Reference clock

You can select either the internal or external 10 MHz reference clock source by using the SETUP horizontal menu. When you select the external source, the reference signal connected to the 10 MHz REF IN connector on the rear panel is used.

Master clock

The clock signal of the desired frequency is acquired with a programmable oscillator and dividers using a 10 MHz reference clock. You can select either the internal or external master clock by using the SETUP horizontal menu.

When you select the external master clock source, the external clock signal connected to the MASTER CLOCK IN connector on the rear panel is used. In this case, the dividers are bypassed and the connected external master clock signal is sent to the MASTER CLOCK OUT connector on the rear panel without change.

When you select the internal clock source, the internal clock signal generated by programmable oscillator is used and is sent to the dividers. In this case, since the

master clock out signal is sent through the dividers, the frequency of the master clock out signal from the MASTER CLOCK OUT connector is different from the clock frequency set up with the Horizontal Clock menu.

The relation of the clock frequency set up with the Horizontal menu and the frequency of the master clock outputted from the MASTER CLOCK OUT is as follows:

$$100 \text{ MS/s} \leq \text{MCLout} = \text{CL} \times 2^n \text{ (; n is one value of 0 to 14)} \leq 200 \text{ MS/s}$$

MCLout : the frequency of signal outputted from the MASTER CLOCK OUT

CL : the frequency set up with the Horizontal clock menu

External Clock input

If you select the external clock source by using the SETUP Horizontal Clock source, the external clock signal connected to the CLOCK IN connector on the rear panel is used.

Memory Address Control

This Memory Address Control controls the addresses used to read waveform memory data (see Figure 3–3).

This block loads into the Address Counter the first address of the waveform loaded into the waveform memory. It loads the waveform data length to the Length Counter. The Address Counter specifies the point from which the waveform was generated, and the Length Counter specifies the waveform ending position.

The Address and Length Counters operate with clocks produced by quarter-frequency division for the clocks from the clock oscillator.

If the repeat count value has been loaded in the Repeat Counter, the waveform is generated the specified number of times.

This block also controls the sequence to the event signals generated in Enhanced Mode.

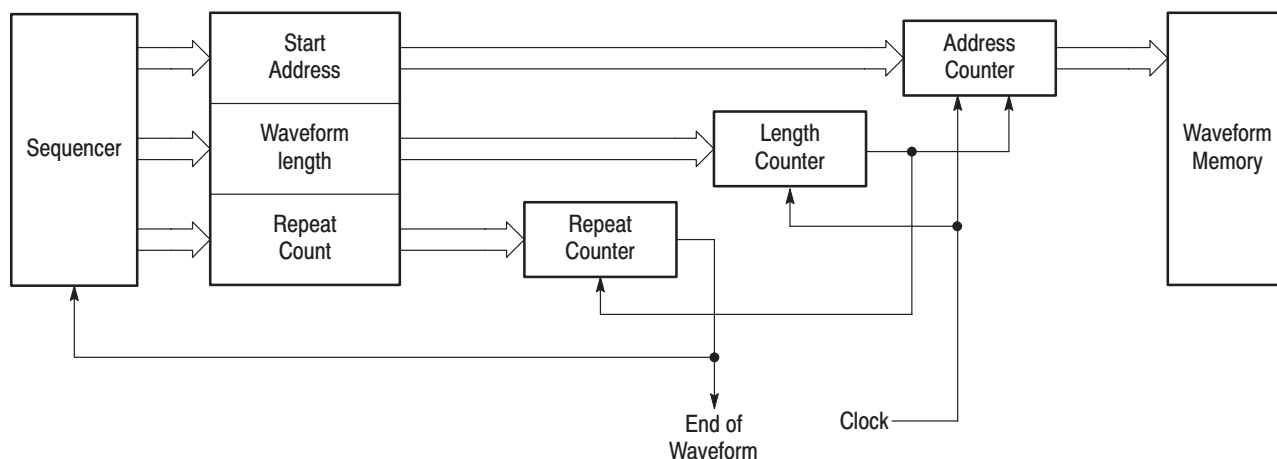

Figure 3–3: Relationship between memory address control and waveform memory

Trigger Control The Trigger Control block controls Memory Address Control in the operation mode that you specified from the RUN MODE menu.

RUN modes Selecting a RUN mode from the SETUP menu causes one of the modes listed in Table 3–1 to operate the waveform generator.

Table 3–1: Run modes

| Modes | Descriptions |
|------------|---|
| Continuous | Consecutively output regardless of existence of a trigger signal. |
| Triggered | The output signal is obtained only once when one of the following is input: <ul style="list-style-type: none"> ■ An external trigger signal from the TRIG IN connector on the rear panel. ■ A trigger signal generated with the FORCE TRIGGER button on the front panel. ■ A trigger command from the remote control. ■ If a SEQUENCE has been defined, a TRIGGERED output is obtained only once according to the definition. |

Table 3-1: Run modes (Cont.)

| Modes | Descriptions |
|----------|---|
| Gated | The waveform is output only while: <ul style="list-style-type: none"> ■ An external trigger signal from the TRIG IN connector on the rear panel. ■ A gate signal through the FORCE TRIGGER button on the front panel is TRUE. ■ A trigger command or an event control command from the remote control. |
| Enhanced | The waveform is obtained, in the order defined by the sequence, based on: <ul style="list-style-type: none"> ■ A trigger signal (for example, an external trigger signal from the TRIG IN connector on the rear panel) ■ An external trigger signal from the TRIG IN connector on the rear panel. ■ An event signal from the EVENT IN connector on the rear panel. ■ A trigger signal generated with the FORCE TRIGGER button on the front panel. ■ A trigger command or event/jump control command from the remote control. |

Waveform Memory and Shift Register

The Waveform Memory block has 16 bits for waveform data and 2 bits per channel for markers, and thus, a total length of of 4,050,000 points. You can set any value from 64 points to 16,200,000 points (for Option 01) for the length of waveform data.

The Shift Register block is used to read waveform data from waveform memory at a rate up to 200 MS/s.

Analog Circuit and Noise Generator

The Analog Circuit block contains the Filter, Attenuator, Output Amplifier, and Offset Circuits that are used to process signals generated from the DA Converter. It also contains the Adder Circuit, used to add the ADD IN signal from the rear panel ADD IN connector and the noise signals generated from the internal noise oscillator.

The noise signals from the internal noise generator are added to the DAC signal.

Digital Data Output (Option 03)

For the option 03, the 16-bit data is sent to the DAC and Clock. The 16-bit data and clock are output on CMOS level via a buffer and P4116 CMOS OUTPUT POD.

Signal Output Process

This section describes the operation of the instrument and the flow of user operations up to the waveform output from the waveform generator.

First, you must load the desired waveform data to be output into the waveform memory. New waveform data can be created using waveform editors incorporated in the waveform generator. It can also be created by combining:

- A sample waveform data distributed with floppy disks
- Previously created waveform data on the built-in hard disk
- Waveform data measured or created by other equipment, which has been read via the network

According to the event control, the waveform data loaded into the waveform memory is fetched at the specified clock rate. This is done in the order in which the memory address controls were specified. After DA conversion, this data is sent to the Analog Circuit.

The waveform is output based on the amplitude, offset, and filter specified in the Analog Circuit. Signals from the built-in noise generator or external signals from the ADD IN connector can be added to the waveform before the waveform is output.

Markers and optional digital data are output without passing through the DA Converter, resulting in changes in amplitude and/or delays (for markers).

Waveform Data Structure

Each waveform generator file may be for either an analog or digital pattern. For analog waveforms, the full scale of the DAC is represented as -1.0 to 1.0 . This range is held with a resolution of 16 bits. The two pieces of marker information, as well as the waveform data, are included. Any digital waveform is held as a total of 3 bytes of data (2 bytes of 16-bit data and 1 byte of 2-bit marker).

About waveform and pattern files

You can load both the waveform and pattern file to output a waveform to the analog and digital output terminals. When you load a waveform file, the instrument converts the waveform to a 16-bit digital pattern and stores it in the waveform memory, while the instrument stores data in the pattern file in the waveform memory without any conversion.

The difference between these two files is an internal format and the editor that you use to modify the file. The waveform file format is composed of 4-byte little endian and 1-byte for each point data and markers. The 4-bytes point data is expressed as IEEE floating point number. On the other hand, the pattern file format is composed of 3-bytes, including data and markers.

When you use waveform data to generate another waveform by mathematical operations such as multiplying, dividing, adding, and so on., you must keep the waveform data as a waveform file. The waveform file format exists for keeping the data precision in mathematical operations.

For more details about file format, refer to the *Data Transfer* section in AWG400-Series programmer manual (Tektronix part number 070-A810-XX).

Waveform Edit

For editing the waveform generator provides you with Waveform, Pattern, Sequence, Equation, and Text Editors. See Table 3–2 for the explanations of these editors.

Table 3–2: Editors

| Editors | Descriptions |
|-----------------|---|
| Waveform Editor | <p>The Waveform Editor lets you create or edit a waveform that is displayed on the screen. It enables you to create any waveform by operations, such as cut and paste, partial inversion about the horizontal or vertical axis, shift, or scaling. This operation can be based on a standard waveform, such as a sine or rectangular wave, or the precreated waveform.</p> <p>The Waveform Editor also has a unique feature that is capable of editing a waveform with waveform calculation functions (absolute value of waveform, differentiation/integration, convolution, correlation, addition/subtraction/multiplication between waveforms, and so on.).</p> |
| Pattern Editor | <p>The Pattern Editor displays a digital signal pattern with a pattern data placed in 16-bit creation waveform memory; it creates a digital signal pattern according to the High/Low settings that you made for the individual bits.</p> <p>In addition to the functions supported by the Waveform Editor, the Pattern Editor is capable of generating frequently-used digital signals unique to digital signals and pseudo-random patterns.</p> |
| Sequence Editor | <p>The Sequence Editor lets you create more complex waveforms by combining a few types of waveform data that you created using Waveform and/or Pattern Editors. This editor also enables a Waveform listing jump and output stop to take place. They follow the external event information from the EVENT IN connector as well as the number of repetitions and the order for the individual pieces of waveform data.</p> |
| Text Editor | <p>The Text Editor creates a equation, or more exactly, a waveform by a method of equations. When an equation has been created using this editor, you need to perform compiling.</p> <p>The Text Editor also enables you to edit a plain ASCII file. The Text Editor should be used to edit ASCII-format waveform data created with other equipment as well as this instrument.</p> |

Quick Edit

The Quick Editor lets you modify and/or output any part of a waveform which you are currently editing with the Waveform Editor in real time. You can scale the data between cursors or shift the data vertically and/or horizontally (Expand/Shift).

Performance Verification

Two types of Performance Verification procedures can be performed on this product: *Self Tests* and *Performance Tests*. You may not need to perform all of these procedures, depending on what you want to accomplish.

- Verify that the AWG400-Series Arbitrary Waveform Generator is operating correctly by running the self tests which begin on page 4–3.

Advantages: These procedures require minimal time to perform, require no additional equipment, and test the internal hardware of the AWG400-Series Arbitrary Waveform Generator.

- If a more extensive confirmation of performance is desired, complete the self test, and then do the performance test beginning on page 4–7.

Advantages: These procedures add direct checking of warranted specifications. They require more time to perform and suitable test equipment is required. (Refer to *Equipment Required* on page 4–8).

Conventions

Throughout these procedures the following conventions apply:

- Each test procedure uses the following general format:

Title of Test

Equipment Required

Test hookup

Prerequisites

Procedure

- Each procedure consists of as many steps, substeps, and subparts as required to do the test. Steps, substeps, and subparts are sequenced as follows:

1. First Step

- a. First Substep

- First Subpart

- Second Subpart

- b. Second Substep

2. Second Step

- Instructions for menu selection use the following format: **front-panel BUTTON→Main Menu Button→Side Menu Button**. For example, Push **UTILITY→System→Reset to Factory→OK**
- The name of the button or knob appears in boldface type:
Push **EDIT**; then **Drive...**, push **Floppy** side button and use the knob to select SINE.WFM from the Performance Check/Adjustments disk.

Self Tests

The *Self Tests* use internal routines to confirm basic functionality and proper adjustment. No test equipment is required to do these test procedures.

The self tests include internal diagnostics to verify that the instrument passes the internal circuit tests and calibration routines to check and adjust the instrument internal calibration constants.

Diagnostics

This procedure uses internal routines to verify that the instrument is operating correctly. No test equipment or hookups are required.

The instrument automatically performs the internal diagnostics when powered on; you can also run the internal diagnostics using the menu selections described in this procedure. The difference between these two methods of initiating the diagnostics is that the menu method does a more detailed memory check than the power-on method.

| | |
|---------------------------|---|
| Equipment required | None |
| Prerequisites | Power on the instrument and allow a twenty-minute warm-up period before doing this procedure. |

Confirm that there is no signal output by verifying that the RUN LED is not lighted. If the LED is lighted, push the **RUN** button to turn it off.

Do the following to verify that the instrument passes the internal circuit tests:

Push **UTILITY** (front-panel)→**Diag** (bottom)→**Diagnostic All** (side).

The diagnostic menu is displayed, and all tests are selected. Refer to Figure 4–1. If All is not displayed, select All using the general purpose knob.

The list on the screen shows the test items and results of the calibration and diagnostics previously made. Select all of the test items shown on the screen or use the general purpose knob to select a single test item that you want to run. The result of the diagnostics are shown as error codes. Pass means that the tests have been made without error. If an error is detected, an error code is displayed.

You can also specify how many times the diagnostic tests are performed. Push the **Cycle** side button, and then turn the general purpose knob to select the cycle from 1, 3, 10, 100 or Infinite. When you select Infinite, the tests are repeatedly performed and are not terminated until you push the Abort Diagnostic side button.

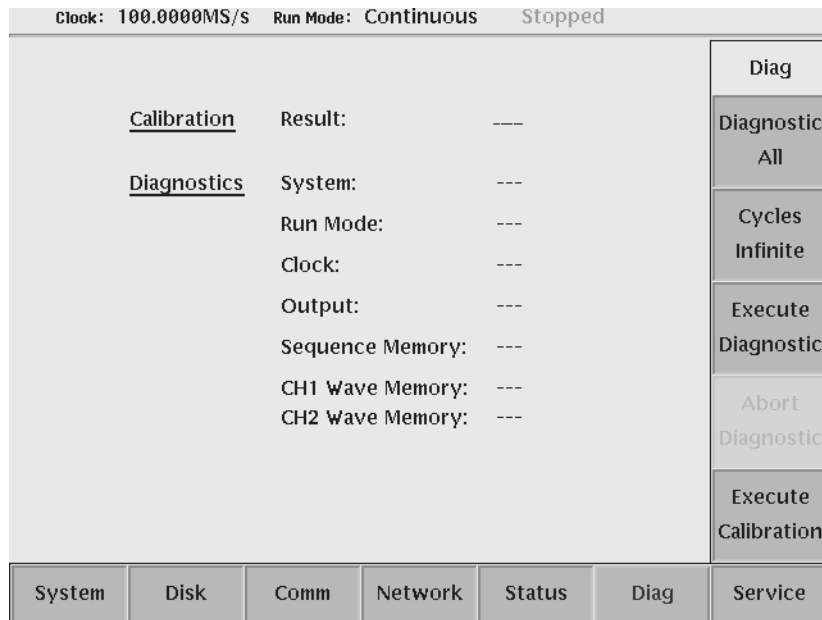

Figure 4-1: Diagnostic menu

Do the following to execute all of the AWG400-Series Arbitrary Waveform Generator diagnostics automatically:

Push the **Execute Diagnostic** side button.

NOTE. Push the *Abort Diagnostic* button (side menu) to stop a selected diagnostic after it is completed. This button does not stop the diagnostic while it is processing. The *Abort* button stops any further diagnostics from operating.



The internal diagnostics do an extensive verification of AWG400-Series Arbitrary Waveform Generator functions. While this verification progresses, the screen displays the clock icon. When finished, the resulting status appears on the screen.

Verify that no failures are found and reported on the screen. If the diagnostics terminates without error, Pass is displayed instead of the - - -. If a value is displayed, meaning an error is detected, consult a qualified service technician for further assistance.

Push any bottom or menu button (other than **UTILITY**) to exit the diagnostic screen.

Calibration

The instrument includes internal calibration routines that check electrical characteristics such as offset, attenuations and filters. Perform calibration to

adjust internal calibration constants as necessary. This procedure describes how to do the internal calibration.

| | |
|---------------------------|---|
| Equipment required | None |
| Prerequisites | Power on the instrument and allow a 20 minute warm-up period at an ambient temperature between +20° C and +30° C before doing this procedure. |

Confirm that there is no signal output by verifying that the RUN LED is not lighted. If the LED is lighted, push the **RUN** button to turn it off.

NOTE. Some calibration items may fail if you start calibration while output is being performed.

Do the following steps to verify that the internal adjustments have passed:

1. Push **UTILITY** (front-panel)→**Diag** (bottom)→ **Execute Calibration** (side).

This executes the AWG400-Series Arbitrary Waveform Generator calibration routines automatically.



While this internal calibration progresses, a message box displaying *Executing Calibration* appears on screen. When finished, the resulting status appears in the message box as shown in Figure 4–2.

| Clock: 100.0000MS/s | | Run Mode: Continuous | | Stopped | |
|----------------------------|------|----------------------|---------|---------|---------|
| CALIBRATION RESULTS | | | | | |
| | CH 1 | CH 2 | | | |
| Internal Offset: | Pass | Pass | | | |
| Output Offset: | Pass | Pass | | | |
| Gain: | Pass | Pass | | | |
| Direct Output: | Pass | Pass | | | |
| Attenuator 5dB: | Pass | Pass | | | |
| 10dB1: | Pass | Pass | | | |
| 10dB2: | Pass | Pass | | | |
| 20dB: | Pass | Pass | | | |
| Filter 1MHz: | Pass | Pass | | | |
| 5MHz: | Pass | Pass | | | |
| 20MHz: | Pass | Pass | | | |
| 50MHz: | Pass | Pass | | | |
| | | | | | OK |
| System | Disk | Comm | Network | Status | Diag |
| | | | | | Service |

Figure 4–2: Calibration result message box

Verify that no failures are reported in the message box. If the calibration displays Fail as the result, consult a qualified service technician for further assistance.

2. Push the **OK** side button and then any bottom or menu button (other than the **UTILITY**) to exit the dialog screen.

NOTE. *The calibration data in the memory may be lost if the instrument is powered off while the calibration is executing.*

Performance Tests

This section contains a collection of procedures for checking that the AWG400-Series Arbitrary Waveform Generator performs as warranted.

The procedures are arranged in thirteen logical groupings, presented in the order shown in Table 4-1.

Table 4-1: Performance test items

| Titles | See (performance verification) | Test items | See (specifications) |
|---|--------------------------------|---|----------------------|
| Operating mode tests | Page 4-19 | Continuous, Triggered, and Gated mode | Page 1-4 |
| Clock frequency tests | Page 4-35 | Clock frequency accuracy | Page 1-5 |
| Amplitude and offset accuracy tests (normal out) | Page 4-37 | Amplitude accuracy and DC offset accuracy | Page 1-6 & 1-8 |
| Amplitude, DC offset and rise time accuracy tests (direct DA out) | Page 4-46 | Amplitude accuracy, DC offset accuracy, and Rise time accuracy | Page 1-10 |
| Step response tests (normal out) | Page 4-54 | Rise time accuracy, Aberration, and Flatness | Page 1-8 |
| Internal trigger tests | Page 4-60 | Trigger interval normality | Page 1-5 |
| Trigger input tests | Page 4-62 | Trigger level accuracy and Trigger function normality | Page 1-13 |
| Event input and enhanced mode tests | Page 4-67 | External event input function normality and Event mode normality | Page 1-13 |
| 10 MHz reference input and Master clock tests | Page 4-74 & 4-76 | 10 MHz reference input and Master clock output frequency accuracy | Page 1-14 |
| ADD IN input tests | Page 4-78 | ADD IN input normality and input level accuracy | Page 1-13 |
| Marker output tests | Page 4-81 | Marker output level accuracy | Page 1-10 |
| Channel skew tests | Page 4-84 | Delay between channels function | Page 1-6 |
| Master clock output tests | Page 4-87 | Master clock output | Page 1-10 |
| 10 MHz Reference output tests | Page 4-89 | 10 MHz Reference Clock output | Page 1-11 |
| Digital data output tests | Page 4-91 | Digital data output | Page 1-11 |

The performance tests check all of the characteristics that are designated as checked in *Appendix A: Specifications*. (The characteristic items that must be checked are listed with the check mark (✓) in *Appendix A: Specifications*).

NOTE. These procedures extend the confidence level provided by the basic procedures described on page 4–3. The basic procedures should be done first, and then these procedures performed if desired.

Prerequisites

The tests in this section comprise an extensive, valid confirmation of performance and functionality when the following requirements are met:

- The cabinet must be installed on the instrument.
- Power on the instrument and allow a 20 minute warm-up before doing this procedure.
- You must have performed and passed the procedures under *Self Tests*, found on page 4–3.
- The waveform generator must have been recently calibrated at an ambient temperature between +20° C and +30° C, performance test must be executed an ambient temperature between +10° C and +40° C.

Refer to *Conventions* on page 4–1 for more information.

Equipment Required

These procedures use external, traceable signal sources to directly check warranted characteristics. Table 4–2 lists the required equipment used to complete the performance tests. Figure 4–4 shows the P4116 Pod Output pins and signals.

Table 4–2: Test equipment

| Item number and description | Minimum requirements | Example (recommended) | Purpose |
|--------------------------------------|--|--------------------------------------|--|
| 1. Frequency Counter | 1 MHz to 200 MHz, Accuracy: < 0.2 ppm | Anritsu MF1603A | Used to check reference input test. |
| 2. Digital multimeter | DC volts range: 0.05 V to 10 V, Accuracy: ±0.1% | Fluke 8842A | Used to check to measure voltage. |
| 3. Oscilloscope | Bandwidth: > 500 MHz, 1 M Ω and 50 Ω inputs | Tektronix TDS7104 | Checks output signals. Used in many procedures. |
| 4. Function Generator | Output voltage: –5 V to +5 V, Frequency accuracy: < 0.01% | Sony/Tektronix AFG310 | Generates external input signals. Used in many input signal test procedures. |
| 5. BNC Coaxial Cable (3 required) | 50 Ω , male to male BNC connectors | Tektronix part number 012-0482-00 | Signal interconnection |
| 6. Dual-Banana Connector | BNC (female) to dual banana | Tektronix part number 103-0090-00 | Signal interconnection |
| 7. BNC-T Connector | BNC (male) to BNC (female) to BNC (female) | Tektronix part number 103-0030-00 | Signal interconnection |

Table 4-2: Test equipment (cont.)

| Item number and description | Minimum requirements | Example (recommended) | Purpose |
|---|----------------------------------|--|--------------------------------|
| 8. Precision Terminator (2 required) | 50 Ω, 0.1%, BNC | Tektronix part number 011-0129-00 | Signal termination |
| 9. Performance check disk | Must use example listed | Supplied with the product, Tektronix part number 062-A259-XX | Used to provide waveform files |
| 10. Ground closure (loop-back cable) with 9-pin, D-type connector | | Custom, See Figure 4-3. | Used for event mode test |
| 11. Flat cable | RF Cable assembly 120 cm (47 in) | Tektronix part number 174-3548-00 | Signal interconnection |
| 12. Pin header-SMB cable | | Tektronix part number 012-1503-00 | Signal interconnection |
| 13. SMB-BNC Connector (2 required) | | Tektronix part number 015-0671-00 | Signal interconnection |
| 14. P4116 for Option 3 | | P4116 | Signal termination |

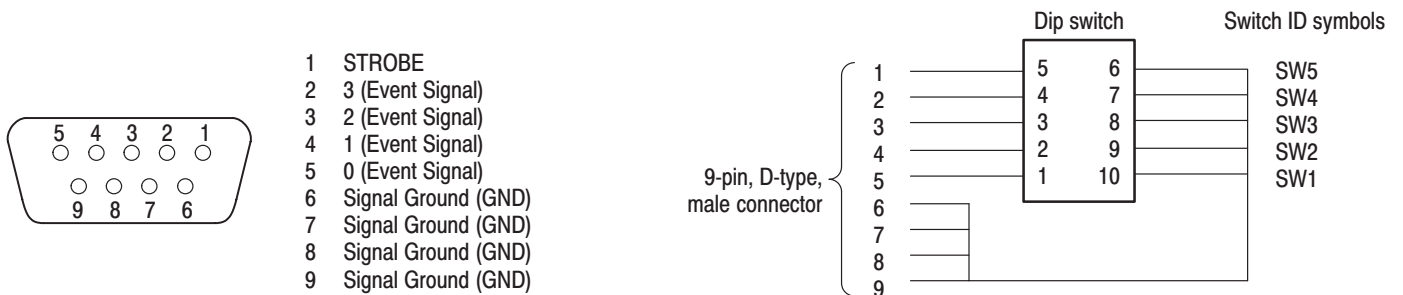

Figure 4-3: EVENT IN connector pins and signals and ground closure connector

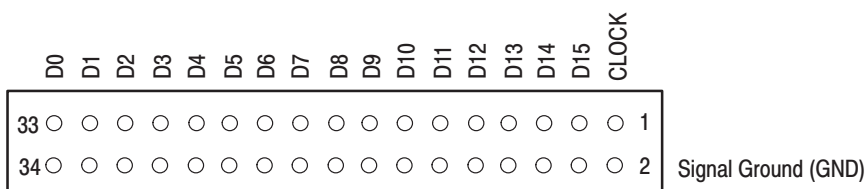

Figure 4-4: P4116 Pod Output pins and signals

Loading Files

The following steps explain how to load files from the Performance Check/Adjustment disk into waveform memory and/or sequence memory.

1. Insert the AWG400-Series Performance check/ Adjustment disk (Tektronix part number 062-A259-xx) into the AWG400-Series Arbitrary Waveform Generator floppy disk drive.
2. Push **CH1**, **CH2**, or **CH3** front button to select the channel to be loaded.
3. Select **SETUP** (front)→**Waveform/Sequence** (bottom)→**Load...** (side)→**Drive...** (side).

The Select Drive dialog box appears as shown in Figure 4–5.

4. Select **Floppy** from the dialog box with the general purpose knob, and then push the **OK** side button.

The Select Drive dialog box disappears, and the files in the floppy disk are listed on the Select File dialog box.

5. Use the general purpose knob to select a file to be loaded from the dialog box, and then push the **OK** side button.

The waveform or sequence that you selected is loaded into the instrument, and the instrument is also set up with the parameters stored in that file.

6. Remove the floppy disk from the floppy drive if the floppy disk is no longer needed.
7. Push any bottom button or menu button to exit the menu.

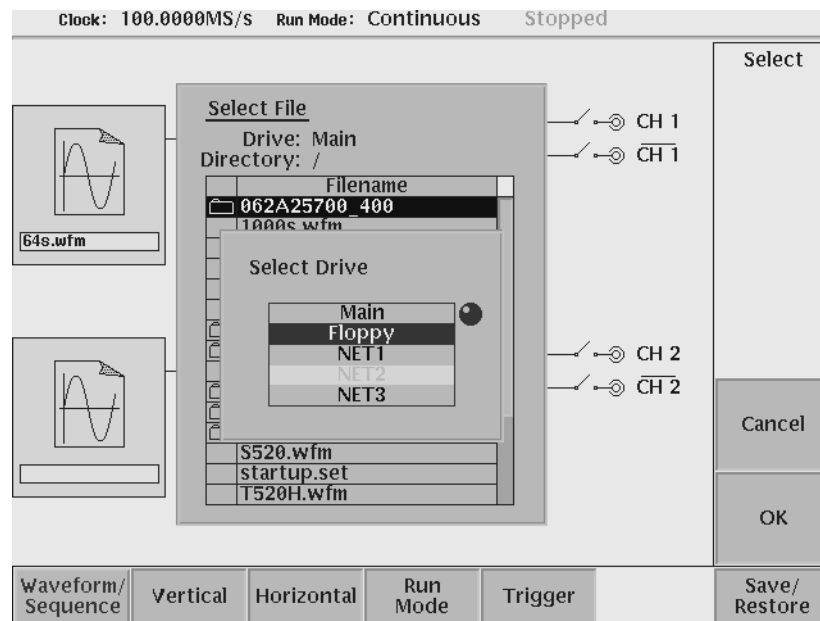

Figure 4-5: Loading file; selecting storage drive

Performance Check/Adjustment Files

Table 4–3 lists the sequence and waveform files on the Performance Check/Adjustment disk that are used in the performance test. These files are loaded when you perform each check item. The file also includes test pattern data and setup information.

Table 4–3: Waveforms and sequences in performance check disk







| No. | File name | EDIT menu | | SETUP menu | | | | Marker setup | Usage |
|-----|--|---|--------|------------|---------|-------|--------|--|---|
| | | Form | Points | Clock | Filter | Ampl | Offset | | |
| 1 | MODE.WFM |  | 1000 | 200 MS/s | Through | 1 V | 0 V | Marker1,2: 0 to 499: High, 500 to 999: Low | Run mode, Trigger level, Marker, External clock input |
| 2 | PULSE.WFM |  | 1000 | 100 MS/s | Through | 1 V | 0 V | | Pulse amplitude, Internal trigger accuracy |
| 3 | SINE.WFM |  | 256 | 200 MS/s | Through | 1 V | 0 V | | Sine characteristics |
| 4 | DOOUT.PAT |  | 512 | 100 MS/s | Through | 1 V | 0 V | | Digital data out |
| 5 | AMP1.SEQ | | | | | | | | Amplitude accuracy (Normal out) |
| 6 | AMP2.SEQ | | | | | | | | Amplitude accuracy (Direct out) |
| 7 | DC_P.WFM (AMPx.SEQ) ¹ |  | 1000 | 100 MS/s | Through | 1 V | 0 V | | Amplitude accuracy |
| 8 | DC_M.WFM (AMPx.SEQ) ¹ |  | 1000 | 100 MS/s | Through | 1 V | 0 V | | Amplitude accuracy |
| 9 | DC0.WFM (AMP2.SEQ) |  | 1000 | 100 MS/s | Through | 1 V | 0 V | | Amplitude accuracy |
| 10 | OFFSET.WFM |  | 1000 | 100 MS/s | Through | 20 mV | 0 V | | Offset accuracy |
| 11 | TRIG.WFM |  | 1000 | 1 MS/s | Through | 1 V | 0 V | | Trigger input |
| 12 | PT_EVENT.SEQ | | | | | | | | Event input |
| 13 | PT_STROB.SEQ | | | | | | | | Event input |
| 14 | S260.WFM (PT_xxxx.SEQ) ² |  | 260 | 100 MS/s | Through | 1 V | 0 V | | Event input |

Table 4-3: Waveforms and sequences in performance check disk (cont.)

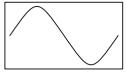
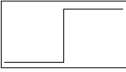
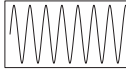
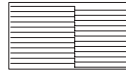
| No. | File name | EDIT menu | | SETUP menu | | | | Marker setup | Usage |
|-----|---|---|--------|------------|---------|------|--------|--------------|----------------------|
| | | Form | Points | Clock | Filter | Ampl | Offset | | |
| 15 | S260H.WFM (PT_XXXX.SEQ) ² |  | 260 | 100 MS/s | Through | 1 V | 0 V | | Event input |
| 16 | R260H.WFM (PT_XXXX.SEQ) ² |  | 260 | 100 MS/s | Through | 1 V | 0 V | | Event input |
| 17 | T260H.WFM (PT_XXXX.SEQ) ² |  | 260 | 100 MS/s | Through | 1 V | 0 V | | Event input |
| 18 | Q260H.WFM (PT_XXXX.SEQ) ² |  | 260 | 100 MS/s | Through | 1 V | 0 V | | Event input |
| 19 | HSIN.WFM |  | 999 | 99.9 MS/s | Through | 1 V | 0 V | | Sine characteristics |

¹ The AMPx.SEQ represents AMP1.SEQ and AMP2.SEQ.

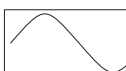
² The PT_XXXX.SEQ represents PT_EVENT.SEQ and PT_STROB.SEQ

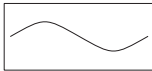
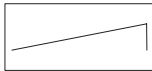
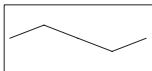
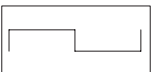
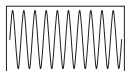
AWG400-Series Test Record

Photocopy this test record and use to record the performance test results for your AWG400-Series.

AWG400-Series Test Record

Instrument Serial Number: _____ Certificate Number: _____
 Temperature: _____ RH %: _____
 Date of Calibration: _____ Technician: _____

| AWG400-Series Performance Test | | Minimum | Incoming | Outgoing | Maximum |
|--|------------------|-----------|----------|----------|-----------|
| Operating Mode | | | | | |
| Check Cont Mode | | Pass/Fail | _____ | _____ | Pass/Fail |
| Check Triggered Mode (when the FORCE TRIGGER button is pushed) | | Pass/Fail | _____ | _____ | Pass/Fail |
| Check Triggered Mode (with external triggering) | | Pass/Fail | _____ | _____ | Pass/Fail |
| Check Gated Mode (when the FORCE TRIGGER button is pushed) | | Pass/Fail | _____ | _____ | Pass/Fail |
| Check Gated Mode (with the gate signal when the AWG trigger polarity is set to positive) | | Pass/Fail | _____ | _____ | Pass/Fail |
| Check Gated Mode (with the gate signal when the AWG trigger polarity is set to negative) | | Pass/Fail | _____ | _____ | Pass/Fail |
| Amplitude and Offset Accuracy (Normal Out) | | | | | |
| CH1 Amplitude | 20 mV | 17.70 mV | _____ | _____ | 22.30 mV |
| | 200 mV | 195.0 mV | _____ | _____ | 205.0 mV |
| | 2 V | 1.9680 V | _____ | _____ | 2.0320 V |
| | 5 V (Opt 5 only) | 4.923 V | _____ | _____ | 5.077 V |
| CH2 Amplitude | 20 mV | 17.70 mV | _____ | _____ | 22.30 mV |
| | 200 mV | 195.0 mV | _____ | _____ | 205.0 mV |
| | 2 V | 1.9680 V | _____ | _____ | 2.0320 V |
| | 5 V (Opt 5 only) | 4.923 V | _____ | _____ | 5.077 V |
| CH3 Amplitude | 20 mV | 17.70 mV | _____ | _____ | 22.30 mV |
| | 200 mV | 195.0 mV | _____ | _____ | 205.0 mV |
| | 2 V | 1.9680 V | _____ | _____ | 2.0320 V |
| | 5 V (Opt 5 only) | 4.923 V | _____ | _____ | 5.077 V |

AWG400-Series Test Record (cont.)

Instrument Serial Number: _____ Certificate Number: _____
 Temperature: _____ RH %: _____
 Date of Calibration: _____ Technician: _____

| AWG400-Series Performance Test | | Minimum | Incoming | Outgoing | Maximum |
|--------------------------------|---------------------|-----------|----------|----------|-----------|
| CH1 Amplitude | 20 mV | 17.70 mV | _____ | _____ | 22.30 mV |
| | 200 mV | 195.0 mV | _____ | _____ | 205.0 mV |
| | 2 V | 1.9680 V | _____ | _____ | 2.0320 V |
| CH2 Amplitude | 20 mV | 17.70 mV | _____ | _____ | 22.30 mV |
| | 200 mV | 195.0 mV | _____ | _____ | 205.0 mV |
| | 2 V | 1.9680 V | _____ | _____ | 2.0320 V |
| CH3 Amplitude | 20 mV | 17.70 mV | _____ | _____ | 22.30 mV |
| | 200 mV | 195.0 mV | _____ | _____ | 205.0 mV |
| | 2 V | 1.9680 V | _____ | _____ | 2.0320 V |
| CH1 Offset | 0 V | - 10.0 mV | _____ | _____ | + 10.0 mV |
| | +1 V | + 0.980 V | _____ | _____ | + 1.020 V |
| | -1 V | - 0.980 V | _____ | _____ | - 1.020 V |
| | +2.5 V (Opt 5 only) | +2.465 V | _____ | _____ | +2.535 V |
| | -2.5 V (Opt 5 only) | -2.465 V | _____ | _____ | -2.535 V |
| CH2 Offset | 0 V | - 10.0 mV | _____ | _____ | + 10.0 mV |
| | +1 V | + 0.980 V | _____ | _____ | + 1.020 V |
| | -1 V | - 0.980 V | _____ | _____ | - 1.020 V |
| | +2.5 V (Opt 5 only) | +2.465 V | _____ | _____ | +2.535 V |
| | -2.5 V (Opt 5 only) | -2.465 V | _____ | _____ | -2.535 V |
| CH3 Offset | 0 V | - 10.0 mV | _____ | _____ | + 10.0 mV |
| | +1 V | + 0.980 V | _____ | _____ | + 1.020 V |
| | -1 V | - 0.980 V | _____ | _____ | - 1.020 V |
| | +2.5 V (Opt 5 only) | +2.465 V | _____ | _____ | +2.535 V |
| | -2.5 V (Opt 5 only) | -2.465 V | _____ | _____ | -2.535 V |
| CH1 Offset | 0 V | - 10.0 mV | _____ | _____ | + 10.0 mV |
| | +1 V | + 0.980 V | _____ | _____ | + 1.020 V |
| | -1 V | - 0.980 V | _____ | _____ | - 1.020 V |
| CH2 Offset | 0 V | - 10.0 mV | _____ | _____ | + 10.0 mV |
| | +1 V | + 0.980 V | _____ | _____ | + 1.020 V |
| | -1 V | - 0.980 V | _____ | _____ | - 1.020 V |
| CH3 Offset | 0 V | - 10.0 mV | _____ | _____ | + 10.0 mV |
| | +1 V | + 0.980 V | _____ | _____ | + 1.020 V |
| | -1 V | - 0.980 V | _____ | _____ | - 1.020 V |

AWG400-Series Test Record (cont.)

Instrument Serial Number: _____ Certificate Number: _____
 Temperature: _____ RH %: _____
 Date of Calibration: _____ Technician: _____

| AWG400-Series Performance Test | | Minimum | Incoming | Outgoing | Maximum |
|--|---|-----------|----------|----------|--------------------------------------|
| Amplitude, DC Offset Accuracy and Rise Time (Direct DA Out) | | | | | |
| CH1 Amplitude | 500 mV | 490.5 mV | _____ | _____ | 509.5 mV |
| CH2 Amplitude | 500 mV | 490.5 mV | _____ | _____ | 509.5 mV |
| CH3 Amplitude | 500 mV | 490.5 mV | _____ | _____ | 509.5 mV |
| $\overline{\text{CH1}}$ Amplitude | 500 mV | 490.5 mV | _____ | _____ | 509.5 mV |
| $\overline{\text{CH2}}$ Amplitude | 500 mV | 490.5 mV | _____ | _____ | 509.5 mV |
| $\overline{\text{CH3}}$ Amplitude | 500 mV | 490.5 mV | _____ | _____ | 509.5 mV |
| CH1 Offset | 0 V | - 10.0 mV | _____ | _____ | + 10.0 mV |
| CH2 Offset | 0 V | - 10.0 mV | _____ | _____ | + 10.0 mV |
| CH3 Offset | 0 V | - 10.0 mV | _____ | _____ | + 10.0 mV |
| $\overline{\text{CH1}}$ Offset | 0 V | - 10.0 mV | _____ | _____ | + 10.0 mV |
| $\overline{\text{CH2}}$ Offset | 0 V | - 10.0 mV | _____ | _____ | + 10.0 mV |
| $\overline{\text{CH3}}$ Offset | 0 V | - 10.0 mV | _____ | _____ | + 10.0 mV |
| CH1 Rise Time | 0.5 V Amplitude | N/A | _____ | _____ | 3.0 ns |
| CH2 Rise Time | 0.5 V Amplitude | N/A | _____ | _____ | 3.0 ns |
| CH3 Rise Time | 0.5 V Amplitude | N/A | _____ | _____ | 3.0 ns |
| $\overline{\text{CH1}}$ Rise Time | 0.5 V Amplitude | N/A | _____ | _____ | 3.0 ns |
| $\overline{\text{CH2}}$ Rise Time | 0.5 V Amplitude | N/A | _____ | _____ | 3.0 ns |
| $\overline{\text{CH3}}$ Rise Time | 0.5 V Amplitude | N/A | _____ | _____ | 3.0 ns |
| Pulse Response | | | | | |
| CH1 Rise Time | 1 V Amplitude (10 to 90% point) | N/A | _____ | _____ | 4.0 ns (Standard) 5.0 ns (Opt. 5) |
| CH2 Rise Time | 1 V Amplitude (10 to 90% point) | N/A | _____ | _____ | 4.0 ns (Standard) 5.0 ns (Opt. 5) |
| CH3 Rise Time | 1 V Amplitude (10 to 90% point) | N/A | _____ | _____ | 4.0 ns (Standard) 5.0 ns (Opt. 5) |
| CH1 Flatness | 1 V Amplitude (after 50 ns from rising edge) | - 3.0% | _____ | _____ | + 3.0% |
| CH2 Flatness | 1 V Amplitude (after 50 ns from rising edge) | - 3.0% | _____ | _____ | + 3.0% |
| CH3 Flatness | 1 V Amplitude (after 50 ns from rising edge) | - 3.0% | _____ | _____ | + 3.0% |

AWG400-Series Test Record (cont.)

Instrument Serial Number: _____ Certificate Number: _____
 Temperature: _____ RH %: _____
 Date of Calibration: _____ Technician: _____

| AWG400-Series Performance Test | | Minimum | Incoming | Outgoing | Maximum |
|--|---|-----------|----------|----------|--------------------------------------|
| CH1 Rise Time | 1 V Amplitude (10 to 90% point) | N/A | _____ | _____ | 4.0 ns (Standard) 5.0 ns (Opt. 5) |
| CH2 Rise Time | 1 V Amplitude (10 to 90% point) | N/A | _____ | _____ | 4.0 ns (Standard) 5.0 ns (Opt. 5) |
| CH3 Rise Time | 1 V Amplitude (10 to 90% point) | N/A | _____ | _____ | 4.0 ns (Standard) 5.0 ns (Opt. 5) |
| CH1 Flatness | 1 V Amplitude (after 50 ns from rising edge) | - 3.0% | _____ | _____ | + 3.0% |
| CH2 Flatness | 1 V Amplitude (after 50 ns from rising edge) | - 3.0% | _____ | _____ | + 3.0% |
| CH3 Flatness | 1 V Amplitude (after 50 ns from rising edge) | - 3.0% | _____ | _____ | + 3.0% |
| Internal Trigger | | | | | |
| Internal Trigger function (at the trigger interval to 1 ms) | | Pass/Fail | _____ | _____ | Pass/Fail |
| Internal Trigger function (at the trigger interval to 2 ms) | | Pass/Fail | _____ | _____ | Pass/Fail |

AWG400-Series Test Record (cont.)

Instrument Serial Number: _____ Certificate Number: _____
 Temperature: _____ RH %: _____
 Date of Calibration: _____ Technician: _____

| AWG400-Series Performance Test | Minimum | Incoming | Outgoing | Maximum |
|--|----------------|----------|----------|----------------|
| Trigger Input | | | | |
| Positive Threshold (set the triggering level to 5 V) No trigger when input voltage vary from 0 V to 4.65 V. | Pass/Fail | _____ | _____ | Pass/Fail |
| Trigger when input voltage vary from 4.65 V to 5.35 V. | Pass/Fail | _____ | _____ | Pass/Fail |
| Negative Threshold (set the triggering level to -5 V) No trigger when input voltage vary from 0 V to -4.65 V. | Pass/Fail | _____ | _____ | Pass/Fail |
| Trigger when input voltage vary from -5.35 V to -4.65 V. | Pass/Fail | _____ | _____ | Pass/Fail |
| Event Input and Enhanced Mode | | | | |
| Check Event Input with Strobe Off pin 0 (when SW1 of the ground closure is closed) | Pass/Fail | _____ | _____ | Pass/Fail |
| pin 1 (when SW2 of the ground closure is closed) | Pass/Fail | _____ | _____ | Pass/Fail |
| pin 2 (when SW3 of the ground closure is closed) | Pass/Fail | _____ | _____ | Pass/Fail |
| pin 3 (when SW4 of the ground closure is closed) | Pass/Fail | _____ | _____ | Pass/Fail |
| Check Strobe Input (when SW5 of the ground closure is on and off) | Pass/Fail | _____ | _____ | Pass/Fail |
| Master Clock Frequency and 10 MHz Reference Input | | | | |
| Check Master Clock Out Frequency Internal Clock = 100 MHz | 99,980,000 Hz | _____ | _____ | 100,020,000 Hz |
| Check output with 10 MHz Reference Input 10 MHz Ref In = 10 MHz | 99,995,000 Hz | _____ | _____ | 100,005,000 Hz |
| Check output with 10.1 MHz Reference Input 10 MHz Ref In = 10.1 MHz | 100,995,000 Hz | _____ | _____ | 101,005,000 Hz |
| Master Clock Output Level | | | | |
| Check Master Clock Amplitude | 0.7 V | _____ | _____ | 1.3 V |
| 10 MHz Reference Output Level | | | | |
| Check 10 MHz Clock Amplitude | 1.0 V | _____ | _____ | N/A |

AWG400-Series Test Record (cont.)

Instrument Serial Number: _____ Certificate Number: _____
 Temperature: _____ RH %: _____
 Date of Calibration: _____ Technician: _____

| AWG400-Series Performance Test | Minimum | Incoming | Outgoing | Maximum |
|--|----------------|-----------------|-----------------|----------------|
| Marker Output | | | | |
| MARKER1 Low level | 0.0 V | _____ | _____ | 0.1 V |
| MARKER1 High level | 2.4 V | _____ | _____ | 2.5 V |
| MARKER2 Low level | 0.0 V | _____ | _____ | 0.1 V |
| MARKER2 High level | 2.4 V | _____ | _____ | 2.5 V |
| MARKER3 Low level | 0.0 V | _____ | _____ | 0.1 V |
| MARKER3 High level | 2.4 V | _____ | _____ | 2.5 V |
| Channel Skew | | | | |
| CH 2 Skew (when set to reset) | -100 ps | _____ | _____ | +100 ps |
| CH 2 Skew Range (-2.52 ns to +2.52 ns) | Pass/Fail | _____ | _____ | Pass/Fail |
| CH 3 Skew (when set to reset) | -100 ps | _____ | _____ | +100 ps |
| CH 3 Skew Range (-2.52 ns to +2.52 ns) | Pass/Fail | _____ | _____ | Pass/Fail |

Operating Mode Tests

The following procedures verify the operation of the Continuous, Triggered and Gated modes.

NOTE. You need to verify $\overline{CH1}$ and $\overline{CH1}$ outputs for AWG410, the $\overline{CH1}$, $\overline{CH1}$, $\overline{CH2}$, and $\overline{CH2}$ outputs for AWG420, and the $\overline{CH1}$, $\overline{CH1}$, $\overline{CH2}$, $\overline{CH2}$, $\overline{CH3}$ and $\overline{CH3}$ outputs for AWG430. If you have option 05, you do not have to verify \overline{CHx} .

When you verify one of the outputs, turn off the other outputs.

Check Continuous Mode (Instrument other than option 05)

| | |
|---------------------------|--|
| Equipment required | Two 50 Ω BNC coaxial cables and an oscilloscope (TDS7104). |
| Prerequisites | The AWG400-Series Arbitrary Waveform Generator must meet the prerequisites listed on page 4-8. |

1. Do the following steps to install the test hookup and set the test equipment controls:
 - a. Use two 50 Ω coaxial cables to connect the AWG400-Series CH1 output connector to the oscilloscope CH1 input connector, and the AWG400-Series $\overline{CH1}$ output connector to the oscilloscope CH2 input connector (see Figure 4-6).

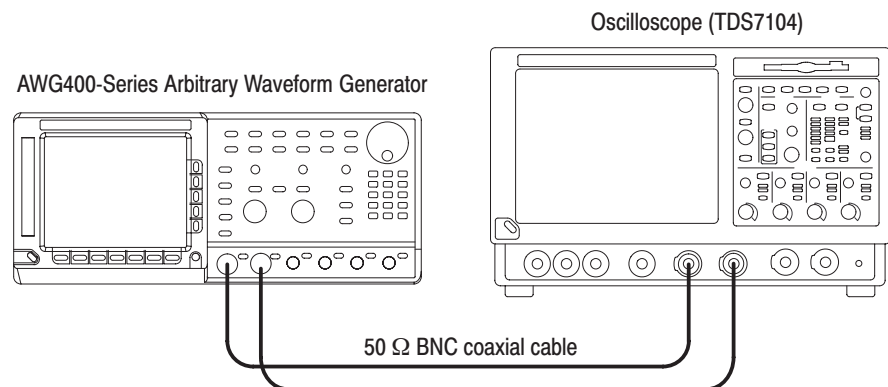

Figure 4-6: Continuous mode initial test hookup (Instrument other than option 05)

- b. Set the oscilloscope controls as follows:

| | |
|--------------------|-----------|
| Vertical | CH1 & CH2 |
| CH1 coupling | DC |
| CH1 scale | 0.2 V/div |

| | |
|---------------------|---------------|
| CH1 input impedance | 50 Ω |
| CH2 coupling | DC |
| CH2 scale | 0.2 V/div |
| CH2 input impedance | 50 Ω |
| Horizontal | |
| Sweep | 2 μ s/div |
| Trigger | |
| Source | CH1 |
| Coupling | DC |
| Slope | Positive |
| Level | +100 mV |
| Mode | Auto |

2. Set up the AWG400-Series, and load the waveform file:
 - a. Reset the AWG400-Series:
Push **UTILITY** (front-panel)→**System** (bottom)→**Factory Reset** (side)→**OK** (side).
 - b. Select the channel:
Push the desired channel select button **CHx** (left side of the front panel) that you want to verify.
 - c. Load the MODE.WFM file for CH1.

Refer to *Loading Files* on page 4–10 for file loading procedures.
3. Push the **RUN**, **CH1 OUTPUT**, and **$\overline{\text{CH1}}$ OUTPUT** front-panel buttons.

The LEDs above the RUN button, CH1 and $\overline{\text{CH1}}$ output connectors are on.
4. Verify that the amplitude of the sine wave displayed on the oscilloscope is 5 vertical divisions (1 V) and that a waveform of approximately one cycle per 2.5 horizontal divisions (5 μ s) is displayed.
5. Push the **RUN**, **CH1 OUTPUT**, and **$\overline{\text{CH1}}$ OUTPUT** front panel buttons to disable the output.

The LEDs above the RUN button, CH1, and $\overline{\text{CH1}}$ output connectors turn off.
6. Disconnect the cables connected to CH1, and $\overline{\text{CH1}}$ output connectors, and connect them to the next channel.
7. Repeat step 2 through step 6 for CH2 and $\overline{\text{CH2}}$ outputs and CH3 and $\overline{\text{CH3}}$ outputs (if applicable).
8. Disconnect the cables from the oscilloscope.

Check Continuous Mode (Instrument with option 05)

| | |
|---------------------------|--|
| Equipment required | A 50 Ω BNC coaxial cable and an oscilloscope (TDS7104). |
| Prerequisites | The AWG400-Series Arbitrary Waveform Generator must meet the prerequisites listed on page 4–8. |

1. Do the following steps to install the test hookup and set the test equipment controls:
 - a. Use a 50 Ω coaxial cable to connect the AWG400-Series CH1 output connector to the oscilloscope CH1 input connector (see Figure 4–7).

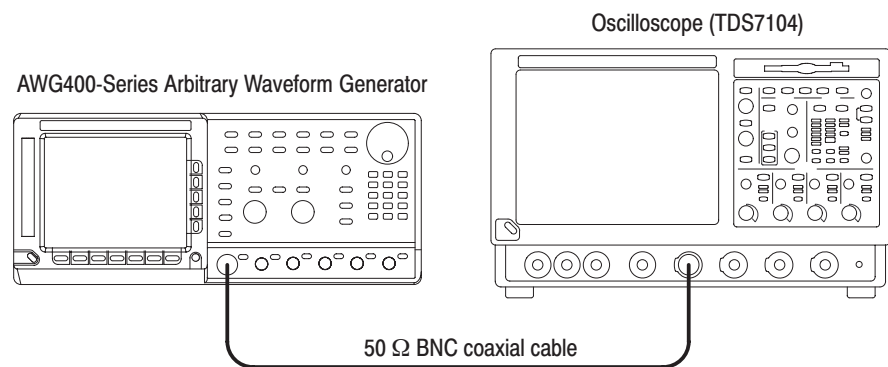

Figure 4–7: Continuous mode initial test hookup (Instrument with option 05)

- b. Set the oscilloscope controls as follows:

| | |
|---------------------|---------------|
| Vertical | CH1 |
| CH1 coupling | DC |
| CH1 scale | 0.2 V/div |
| CH1 input impedance | 50 Ω |
| Horizontal | |
| Sweep | 2 μ s/div |
| Trigger | |
| Source | CH1 |
| Coupling | DC |
| Slope | Positive |
| Level | +100 mV |
| Mode | Auto |

2. Set up the AWG400-Series, and load the waveform file:
 - a. Reset the AWG400-Series:
Push **UTILITY** (front-panel)→**System** (bottom)→**Factory Reset** (side)→**OK** (side).
 - b. Select the channel:
Push the desired channel select button **CHx** (left side of the front panel) for the channel that you want to verify.
 - c. Load the MODE.WFM file for CH1.

Refer to *Loading Files* on page 4–10 for file loading procedures.

3. Push the **RUN** and **CH1 OUTPUT** front-panel buttons.
The LEDs above the RUN button and CH1 output connectors are on.
4. Verify that the amplitude of the sine wave displayed on the oscilloscope is 5 vertical divisions (1 V) and that a waveform of approximately one cycle per 2.5 horizontal divisions (5 μ s) is displayed.
5. Push the **RUN** and **CH1 OUTPUT** front panel buttons to disable the output.
The LEDs above the RUN button and CH1 output connectors turn off.
6. Disconnect the cables connected to CH1 output connector, and connect them to next channel.
7. Repeat steps 2 through step 6 for CH2 and CH3 outputs.
8. Disconnect the cable from oscilloscope.

Check Triggered Mode (Instrument other than option 05)

The following table lists the equipment and prerequisites required to verify the Triggered mode.

| | |
|---------------------------|---|
| Equipment required | Four 50 Ω BNC coaxial cables, a BNC-T (male to 2 females) adapter, a function generator (AFG310), and an oscilloscope (TDS7104). |
| Prerequisites | The AWG400-Series Arbitrary Waveform Generator must meet the prerequisites listed on page 4-8. |

1. Do the following steps to install the test hookup and set the test equipment controls:
 - a. Use two 50 Ω BNC coaxial cable to connect the AWG400-Series CH1 output connector to the oscilloscope CH1 input connector, and the AWG400-Series CH2 output connector to the oscilloscope CH2 input connector. Connect a BNC-T adapter to the TRIG IN connector of AWG400-Series, and connect a 50 Ω BNC coaxial cable from the BNC-T adapter to the oscilloscope CH3 input connector. (Refer to Figure 4-8.)
 - b. Connect the fourth 50 Ω BNC coaxial cable to the BNC-T adapter. Connect the opposite end of the coaxial cable to the function generator output. (Refer to Figure 4-8.)

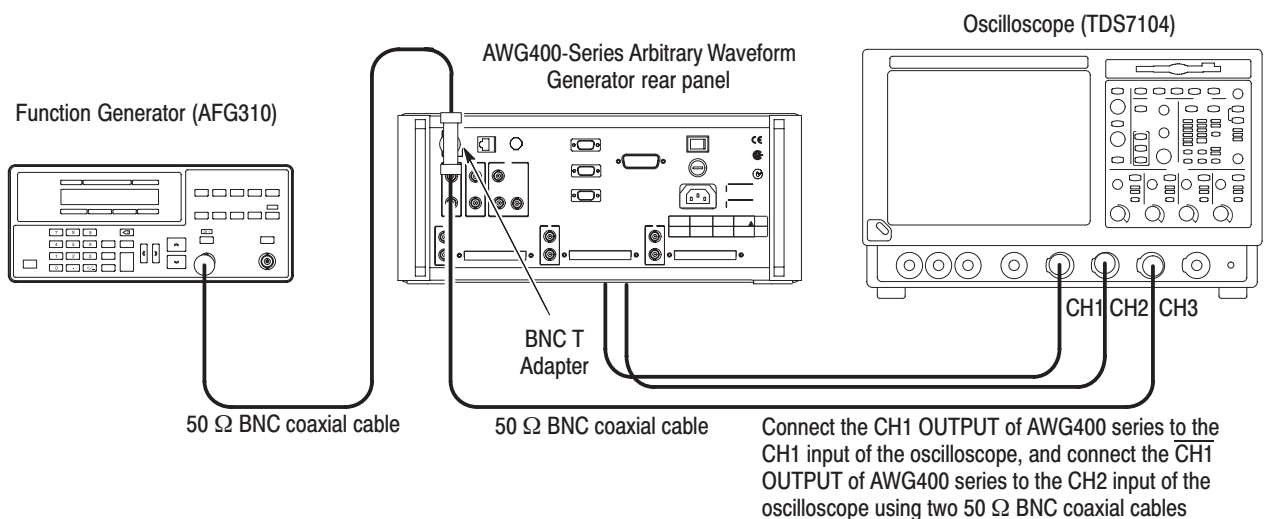

Figure 4-8: Triggered mode initial test hookup (Instrument other than option 05)

- c. Set the oscilloscope controls as follows:

Push the Fast ACQ button on the front panel.

| | |
|---------------------------|-------------------|
| Vertical | CH1, CH2, and CH3 |
| CH1 coupling | DC |
| CH1 scale | 500 mV/div |
| CH1 input impedance | 50 Ω |
| CH2 coupling | DC |
| CH2 scale | 500 mV/div |
| CH2 input impedance | 50 Ω |
| CH3 scale | 2 V/div |
| CH3 input impedance | 1 M Ω |
| Horizontal | |
| Sweep | 2 μ s/div |
| Trigger | |
| Source | CH1 |
| Coupling | DC |
| Slope | Positive |
| Level | +100 mV |
| Mode | Auto |

- d. Set the function generator (AFG310) controls as follows:

| | |
|-----------------|---|
| Function | Square |
| Mode | Continuous |
| Parameters | |
| Frequency | 100 kHz |
| Amplitude | 2.0 V into 50 Ω (4.0 V into 1 M Ω) |
| Offset | 1.0 V into 50 Ω (2.0 V into 1 M Ω) |
| Output | Off |

- 2. Set up the AWG400-Series, and load the waveform file:

- a. Reset the AWG400-Series:

Push **UTILITY** (front-panel)→**System** (bottom)→**Factory Reset** (side)→**OK** (side).

- b. Select the channel:

Push the desired channel button **CHx** (left side of the front-panel) you want to verify.

- c. Select trigger mode:

Push **SETUP** (front-panel)→**Run Mode** (bottom)→**Triggered** (side).

- d. Load the MODE.WFM file for CH1.

Refer to *Loading Files* on page 4–10 for file loading procedures.

3. Push the **RUN**, **CH1 OUTPUT**, and **$\overline{\text{CH1}}$ OUTPUT** front-panel buttons.

The LEDs above the RUN button, CH1 and $\overline{\text{CH1}}$ output connectors are on.

4. Push the **FORCE TRIGGER** front-panel button on the AWG.

Verify that the oscilloscope displays a one-cycle sine wave when the FORCE TRIGGER front-panel button is pushed and held down. You may need to adjust the horizontal position control to see the signal.

5. Follow the substeps below to verify the triggered mode with external triggering:

- a. Turn on the function generator output.
- b. Verify that the oscilloscope displays a one-cycle sine wave for each trigger supplied by the function generator. See Figure 4–9.

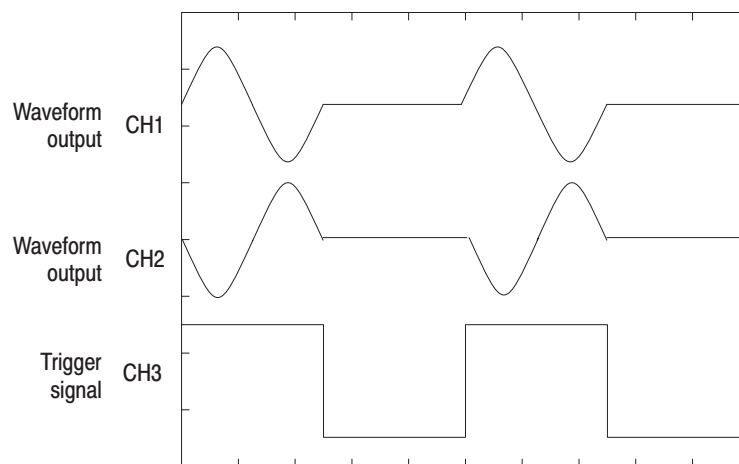

Figure 4–9: Relationship between trigger signal and waveform output (Instrument other than option 05)

6. Push the **RUN**, **CH1 OUTPUT**, and **$\overline{\text{CH1}}$ OUTPUT** front-panel buttons to disable the output.

The LEDs above the RUN button, CH1 and $\overline{\text{CH1}}$ output connectors turn off.

7. Disconnect the cables connected to CH1 and $\overline{\text{CH1}}$ outputs, and connect them to the next channel.
8. Repeat step 2 through step 7 for CH2 and $\overline{\text{CH2}}$ outputs and CH3 and $\overline{\text{CH3}}$ outputs.
9. Stop the function generator output.

**Check Triggered Mode
(Instrument with
option 05)**

The following table lists the equipment and prerequisites required to verify the Triggered mode.

| | |
|---------------------------|--|
| Equipment required | Three 50 Ω BNC coaxial cables, a BNC-T (male to 2 females) adapter, a function generator (AFG310), and an oscilloscope (TDS7104). |
| Prerequisites | The AWG400-Series Arbitrary Waveform Generator must meet the prerequisites listed on page 4–8. |

1. Do the following steps to install the test hookup and set the test equipment controls:
 - a. Use a 50 Ω BNC coaxial cable to connect the AWG400-Series CH1 output connector to the oscilloscope CH1 input connector. Next, connect a BNC-T adapter to TRIG IN connector of AWG400-Series, and connect a 50 Ω BNC coaxial cable from BNC-T adapter to oscilloscope CH2 input connector. (Refer to Figure 4–10.)
 - b. Connect the third 50 Ω BNC coaxial cable to the BNC-T adapter. Connect the opposite end of the coaxial cable to the function generator output. (Refer to Figure 4–10.)

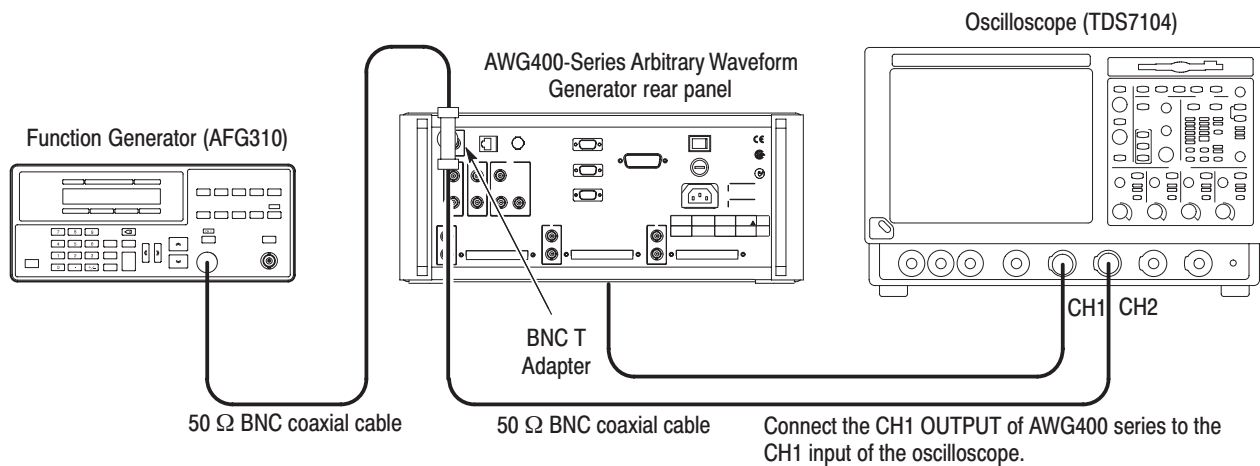

Figure 4–10: Triggered mode initial test hookup (Instrument with option 05)

- c. Set the oscilloscope controls as follows:

Push the Fast Acq button on the front panel.

| | |
|---------------------|---------------|
| Vertical | CH1 and CH2 |
| CH1 coupling | DC |
| CH1 scale | 500 mV/div |
| CH1 input impedance | 50 Ω |
| CH2 scale | 2 V/div |
| CH2 input impedance | 1 M Ω |
| Horizontal | |
| Sweep | 2 μ s/div |
| Trigger | |
| Source | CH1 |
| Coupling | DC |
| Slope | Positive |
| Level | +100 mV |
| Mode | Auto |

- d. Set the function generator (AFG310) controls as follows:

| | |
|------------|---|
| Function | Square |
| Mode | Continuous |
| Parameters | |
| Frequency | 100 kHz |
| Amplitude | 2.0 V into 50 Ω (4.0 V into 1 M Ω) |
| Offset | 1.0 V into 50 Ω (2.0 V into 1 M Ω) |
| Output | Off |

2. Set up the AWG400-Series, and load the waveform file.

- a. Reset the AWG400-Series:

Push **UTILITY** (front-panel)→**System** (bottom)→**Factory Reset** (side)→**OK** (side).

- b. Select the channel:

Push the desired channel button (**CHx**) (left side of the front panel) that you want to verify.

- c. Select trigger mode:

Push **SETUP** (front-panel)→**Run Mode** (bottom)→**Triggered** (side).

- d. Load the MODE.WFM file for CH1.

Refer to *Loading Files* on page 4–10 for file loading procedures.

3. Push the **RUN** and **CH1 OUTPUT** front-panel buttons.

The LEDs above the RUN button and CH1 output connectors are on.

4. Push the **FORCE TRIGGER** front-panel button.

Verify that the oscilloscope displays a one-cycle sine wave when the FORCE TRIGGER front-panel button is pushed. You may need to adjust the horizontal position control to see the signal.

5. Follow the substeps below to verify the triggered mode with external triggering:

- a. Turn on the function generator output.
- b. Verify that the oscilloscope displays a one-cycle sine wave for each trigger supplied by the function generator. See Figure 4–11.

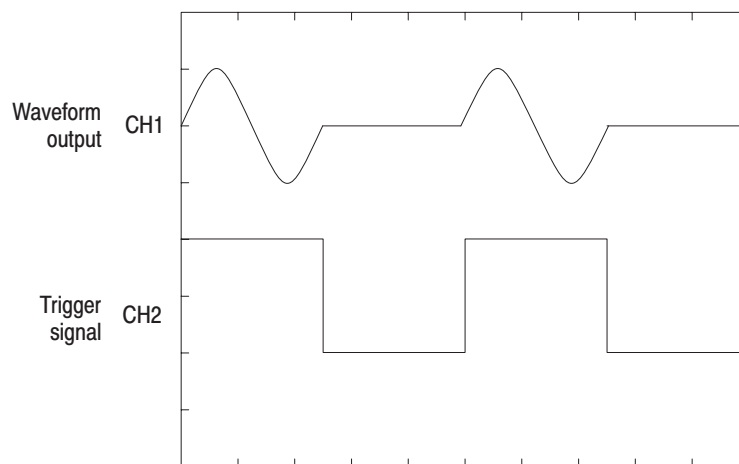

Figure 4-11: Relationship between trigger signal and waveform output (Instrument with option 05)

6. Push the **RUN** and **CH1 OUTPUT** front-panel buttons to disable the output.
The LEDs above the RUN button and CH1 output connectors turn off.
7. Disconnect the cables connected to CH1 output, and connect them to next channel.
8. Repeat step 2 through step 7 for CH2 and CH3 outputs.
9. Stop the function generator output.

**Verify Gated Mode
(Instrument other than
option 05)**

| | |
|---------------------------|--|
| Equipment required | Four 50 Ω BNC coaxial cables, a BNC-T (male to 2 females) adapter, a function generator, and an oscilloscope (TDS7104). |
| Prerequisites | The AWG400-Series Arbitrary Waveform Generator must meet the prerequisites listed on page 4–8. |

1. Use the same test hookup as the *Check Triggered Mode (Instrument other than option 05)* procedure. Refer to page 4–23.

2. Do the following substeps to set the test equipment controls:

a. Set the oscilloscope controls as follows:

| | |
|---------------------------------------|------------------|
| Vertical | CH1, CH2 and CH3 |
| CH1, CH2 and CH3 coupling | DC |
| CH1 and CH2 scale | 0.5 V/div |
| CH3 scale | 2 V/div |
| CH1 and CH2 input impedance | 50 Ω |
| CH3 input impedance | 1 M Ω |
| Horizontal | |
| Sweep | 1 μ s/div |
| Trigger | |
| Source | CH1 |
| Coupling | AC |
| Slope | Positive |
| Level | 0 V |
| Mode | Auto |

b. Set the function generator (AFG310) controls as follows:

| | |
|----------------------|---|
| Function | Square |
| Mode | Continuous |
| Parameters | |
| Frequency | 10 kHz |
| Amplitude | 2.0 V into 50 Ω (4.0 V into 1 M Ω) |
| Offset | 1.0 V into 50 Ω (2.0 V into 1 M Ω) |
| Output | Off |

3. Set up the AWG400-Series, and load the waveform file:

a. Push **UTILITY** (front-panel)→**System** (bottom)→**Factory Reset** (side)→**OK** (side).

b. Select the channel:
Push the desired channel button (**CHx**) (left side of the front panel) that you want to verify.

- c. Push **SETUP** (front-panel)→**Run Mode** (bottom)→**Gated** (side).
- d. Load the MODE.WFM file.

Refer to *Loading Files* on page 4–10 for file loading procedures.

4. Push the **RUN**, **CH1 OUTPUT**, and **CH1 OUTPUT** front-panel buttons.

The LEDs above the RUN button, CH1, and **CH1** output connectors are on.

5. Push and hold down the **FORCE TRIGGER** front-panel button.

Verify that the oscilloscope displays a one-cycle sine wave when the FORCE TRIGGER front-panel button is pushed. You may need to adjust the horizontal position control to see the signal.

6. Verify Gated Mode with gate signal:

- a. Change horizontal setup of oscilloscope to 20 μ s/div.

- b. Change the oscilloscope trigger source to CH3.

- c. Gated signal output:
Turn on the function generator output.

- d. Verify gated mode with positive gate signal:
Verify that the oscilloscope displays a sine wave while the function generator gate signal amplitude is High level. See Figure 4–12.

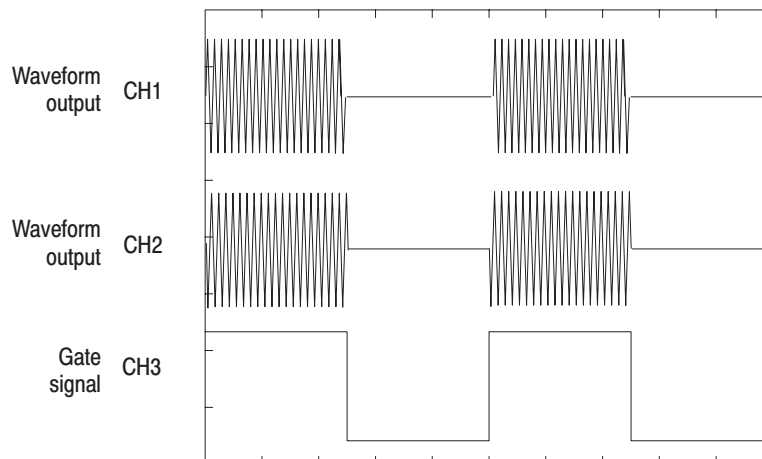

Figure 4–12: Relationship between gate signal and waveform output (Instrument other than option 05)

- e. Verify gated mode with negative gate signal:
Push **SETUP** (front-panel)→**Trigger** (bottom)→**Negative** (side).

This changes the AWG400-Series trigger polarity to negative.

f. Verify that the oscilloscope displays a sine wave while the function generator gate signal amplitude is Low level.

7. Push the **RUN**, **CH1 OUTPUT**, and **$\overline{\text{CH1}}$ OUTPUT** front-panel buttons to disable the output.

The LEDs above the RUN button, CH1, and $\overline{\text{CH1}}$ output connectors turn off.

8. Disconnect the cables connected to CH1 and $\overline{\text{CH1}}$ outputs, and connect them to next channel.
9. Repeat step 2 through step 7 for CH2 and $\overline{\text{CH2}}$ outputs and CH3 and $\overline{\text{CH3}}$ outputs.
10. Turn off the function generator output and disconnect from the oscilloscope.

**Check Gated Mode
(Instrument with
option 05)**

| | |
|---------------------------|--|
| Equipment required | Three 50 Ω BNC coaxial cables, a 50 Ω SMA coaxial cable, a BNC-T (male to 2 females) adapter, a function generator, and an oscilloscope (TDS7104). |
| Prerequisites | The AWG400-Series Arbitrary Waveform Generator must meet the prerequisites listed on page 4–8. |

1. Use the same test hookup as the *Check Triggered Mode (Instrument with option 05)*. Refer to page 4–26.
2. Do the following substeps to set the test equipment controls:
 - a. Set the oscilloscope controls as follows:

| | |
|----------------------------|---------------|
| Vertical | CH1 and CH2 |
| CH1 and CH2 coupling | DC |
| CH1 scale | 0.5 V/div |
| CH2 scale | 2 V/div |
| CH1 input impedance | 50 Ω |
| CH2 input impedance | 1 M Ω |
| Horizontal | |
| Sweep | 1 μ s/div |
| Trigger | |
| Source | CH1 |
| Coupling | AC |
| Slope | Positive |
| Level | 0 V |
| Mode | Auto |

- b. Set the function generator (AFG310) controls as follows:

| | |
|-----------------|---|
| Function | Square |
| Mode | Continuous |
| Parameters | |
| Frequency | 10 kHz |
| Amplitude | 2.0 V into 50 Ω (4.0 V into 1 M Ω) |
| Offset | 1.0 V into 50 Ω (2.0 V into 1 M Ω) |
| Output | Off |

3. Set up the AWG400-Series, and load the waveform file:
 - a. Push **UTILITY** (front-panel)→**System** (bottom)→**Factory Reset** (side)→**OK** (side).
 - b. Select the channel:
Push the desired channel button (**CHx**) (left side of the front panel) that you want to verify.

- c. Set the gated mode:
Push **SETUP** (front-panel)→**Run Mode** (bottom)→**Gated** (side).

- d. Load the MODE.WFM file.

Refer to *Loading Files* on page 4–10 for file loading procedures.

4. Push the **RUN** and **CH1 OUTPUT** front-panel buttons.

The LEDs above the RUN button and CH1 output connector are on.

5. Push the **FORCE TRIGGER** front-panel button.

Verify that the oscilloscope displays a one-cycle sinewave when the FORCE TRIGGER front panel button is pushed. You may need to adjust the horizontal position control to see the signal.

6. Verify Gated Mode with gate signal:

- a. Change horizontal setup of oscilloscope to 20 μ s/div.

- b. Change the oscilloscope trigger source to CH2.

- c. Gated signal output:
Turn on the function generator output.

- d. Verify gated mode with positive gate signal:
Verify that the oscilloscope displays a sine wave while the function generator gate signal amplitude is High level. See Figure 4–13.

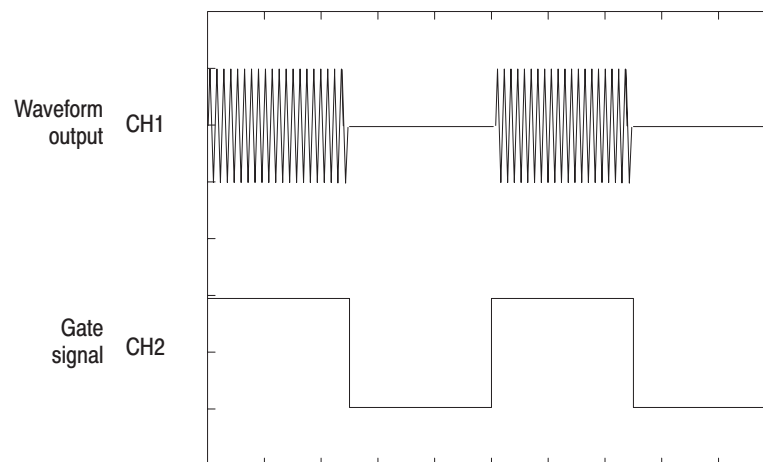

Figure 4–13: Relationship between gate signal and waveform output (Instrument with option 05)

- e. Verify gated mode with negative gate signal:
Push **SETUP** (front-panel)→**Trigger** (bottom)→**Negative** (side).

This changes the AWG400-Series trigger polarity to negative.

- f. Verify that the oscilloscope displays a sine wave while the function generator gate signal amplitude is Low level.
7. Push the **RUN** and **CH1 OUTPUT** front-panel buttons to disable the output.
The LEDs above the RUN button and CH1 output connectors turn off.
 8. Disconnect the cables connected to CH1 output, and connect them to next channel.
 9. Repeat step 2 through step 8 for CH2 and CH3 outputs.
 10. Turn off the function generator output and disconnect from the oscilloscope.

Internal Clock Frequency Tests

These procedures verify the accuracy of the internal clock frequency of the AWG400-Series Arbitrary Waveform Generator.

| | |
|---------------------------|--|
| Equipment required | A 50 Ω BNC coaxial cable and a frequency counter. |
| Prerequisites | The AWG400-Series Arbitrary Waveform Generator must meet the prerequisites listed on page 4-8. |

1. Do the following steps to install the test hookup and set the test equipment controls:
 - a. Connect the frequency counter to the AWG.
Use a 50 Ω BNC coaxial cable to connect the MASTER CLOCK OUT of the AWG400-Series rear panel to A input connector on the frequency counter (see Figure 4-14).

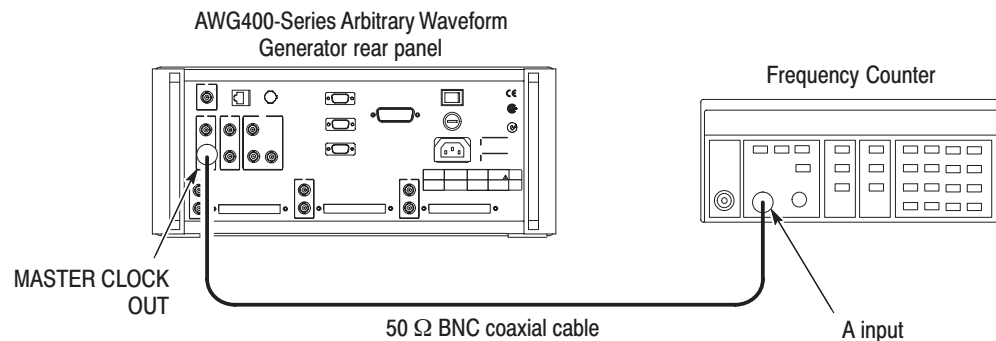



Figure 4-14: Clock frequency and 10 MHz reference input initial test hookup

- b. Set the frequency counter controls as follows:

```

INPUT A
  Slope ..... 
  Coupling ..... AC
FUNCTION ..... A FREQ
Gate time ..... 0.2 s
Trigger Level ..... 0 V
  
```

2. Set up the AWG400-Series, and load the waveform file:
 - a. Reset the AWG400-Series:
Push **UTILITY** (front-panel)→**System** (bottom)→**Factory Reset** (side)→**OK** (side).
 - b. Load the MODE.WFM file.

Refer to *Loading Files* on page 4–10 for file loading procedures.

- c. Select clock frequency:
Push **SETUP** (front-panel)→**Horizontal** (bottom)→**Clock** (side).
 - d. Set frequency:
Push **1**, **0**, **0**, and **M** (SHIFT+7) keys in this order or turn the general purpose knob to set the internal clock frequency to 100 MHz.
3. Verify that the reading on the frequency counter is 100 MHz \pm 200 Hz (2 ppm).
4. Remove test hookup.
5. Disconnect the cable connected to the frequency counter.

Amplitude and Offset Accuracy Tests (Normal Out)

These procedures verify the accuracy of the amplitude and offset outputs of the AWG400-Series.

NOTE. You need to verify $CH1$ and $\overline{CH1}$ outputs for AWG410, the $CH1$, $\overline{CH1}$, and $CH2$, $\overline{CH2}$ outputs for AWG420, and the $CH1$, $\overline{CH1}$, $CH2$, $\overline{CH2}$, $CH3$ and $\overline{CH3}$ outputs for AWG430. If you have option 05, you do not have to verify CHx .

When you verify one of the outputs, turn off the other outputs.

NOTE. The amplitude and offset accuracy verifications are performed as a continuous test. The offset accuracy test uses the same control settings as the amplitude test.

Check Amplitude Accuracy (Instrument other than option 05)

| | |
|---------------------------|---|
| Equipment required | A 50 Ω BNC coaxial cable, a 50 Ω precision terminator, BNC (female)-to-dual banana adapter, and a digital multimeter (DMM). |
| Prerequisites | The AWG400-Series Arbitrary Waveform Generator must meet the prerequisites listed on page 4–8. |

1. Do the following steps to install the test hookup and set the test equipment controls:
 - a. DMM hookup:
Use a 50 Ω BNC coaxial cable, a 50 Ω precision terminator, and a BNC-to-dual banana adapter to connect the AWG400-Series CH1 output to the DMM input connector (see Figure 4–15).

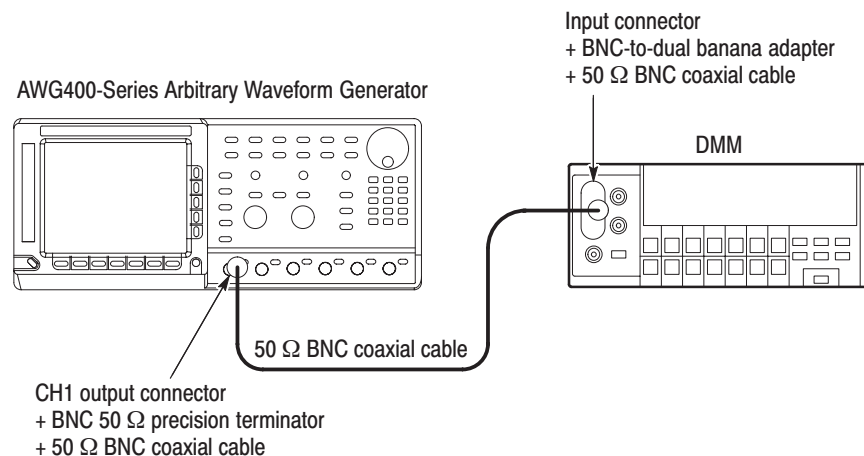

Figure 4–15: Amplitude accuracy initial test hookup

- b. Set the DMM controls as follows:

| | |
|-------------|-------|
| Mode | VDC |
| Range | Auto |
| Input | Front |

- 2. Set up the AWG400-Series, and load the waveform file:
 - a. Push **UTILITY** (front-panel)→**System** (bottom)→**Factory Reset** (side)→**OK** (side).
 - b. Select the channel:
Push the desired channel button **CHx** (left side of the front panel) you want to verify.
 - c. Set the enhanced mode:
Push **SETUP** (front-panel)→**Run Mode** (bottom)→**Enhanced** (side).
 - d. Load the AMP1.SEQ file.

Refer to *Loading Files* on page 4–10 for file loading procedures.

- 3. Push the **RUN** and **CH1 OUTPUT** buttons.

The LEDs above the RUN button and CH1 output connector are on.

- 4. Verify amplitude accuracy:

- a. Do the following substeps to set the AWG400-Series amplitude and confirm the offset setting:
 - Push **VERTICAL MENU** (front-panel)→**Amplitude** (side).
 - Push **0**, **.**, **0**, **2** and **ENTER** keys in this order or turn the general purpose knob to set the amplitude to 0.020 V.
 - Verify that the offset setting display on the Offset side button is 0.000 V by pushing the offset side button.
If the offset display is not set correctly, push the **Offset** side button, and push **0** and then **ENTER** key.
 - Verify that $\overline{\text{CH1}}$ output is off:
If the CH1 output is on, push **CH1 OUTPUT** button to turn it off.
- b. Do the following substeps to verify the amplitude accuracy of the 20 mV amplitude setting:
 - Write down the DMM reading as a positive voltage.
 - Push the **FORCE EVENT** button.
 - Write down the DMM reading as a negative voltage.
 - Verify that the positive minus negative voltages fall within 20 mV ± 2.3 mV.

- c. Push **0**, **.**, **2**, and **ENTER** keys in this order or turn the general purpose knob to set the amplitude to 0.200 V.
- d. Do the following to verify the amplitude accuracy of the 200 mV amplitude setting:
 - Push the **FORCE EVENT** button.
 - Write down the DMM reading as a positive voltage.
 - Push the **FORCE EVENT** button.
 - Write down the DMM reading as a negative voltage.
 - Verify that the positive minus negative voltages fall within $200\text{ mV} \pm 5\text{ mV}$.
- e. Push the **2** and the **ENTER** keys in this order or turn the general purpose knob to set the amplitude to 2 V.
- f. Do the following substeps to verify the amplitude accuracy of a 2 V amplitude setting:
 - Push the **FORCE EVENT** button.
 - Write down the DMM reading as a positive voltage.
 - Push the **FORCE EVENT** button.
 - Write down the DMM reading as a negative voltage.
 - Verify that the positive minus negative voltages fall within $2\text{ V} \pm 0.032\text{ V}$.
5. Do the following substeps to change the connection to $\overline{\text{CH1}}$:
 - Push the **RUN** (front) button and **CH1 OUTPUT** (front) button to turn the output off.
The LEDs above RUN button and CH1 OUTPUT button are off.
 - Disconnect the terminator and cable from the CH1 output connector, and connect to the $\overline{\text{CH1}}$ output connector.
6. Repeat step 3 through step 5 for $\overline{\text{CH1}}$ output.
7. Repeat step 2 through step 6 for CH2 and $\overline{\text{CH2}}$ outputs and CH3 and $\overline{\text{CH3}}$ outputs.
8. Remove test hookup:
 - a. Push $\overline{\text{CHx}}$ **OUTPUT** button you have just verified to turn the $\overline{\text{CHx}}$ LED off.
 - b. Push the **RUN** (front) button to turn the output off.
The LEDs above RUN button are off.

Check Amplitude Accuracy (Instrument with option 05)

| | |
|---------------------------|---|
| Equipment required | A 50 Ω BNC coaxial cable, a 50 Ω precision terminator, BNC (female)-to-dual banana adapter, and a digital multimeter (DMM). |
| Prerequisites | The AWG400-Series Arbitrary Waveform Generator must meet the prerequisites listed on page 4–8. |

1. Do the following steps to install the test hookup and set the test equipment controls:
 - a. DMM hookup:
Use a 50 Ω BNC coaxial cable, a 50 Ω precision terminator, and a BNC-to-dual banana adapter to connect the AWG400-Series CH1 output to the DMM input connector (see Figure 4–16).

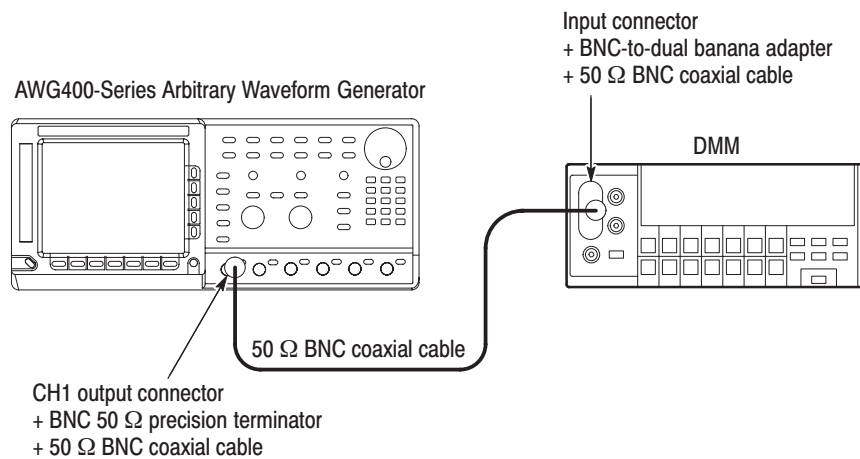

Figure 4–16: Amplitude accuracy initial test hookup

- b. Set the DMM controls as follows:

| | |
|-------------|-------|
| Mode | VDC |
| Range | Auto |
| Input | Front |

2. Set up the AWG400-Series, and load the waveform file:
 - a. Push **UTILITY** (front-panel)→**System** (bottom)→**Factory Reset** (side)→**OK** (side).
 - b. Select the channel:
Push the desired channel button (**CHx**) (left side of the front panel) you want to verify.

- c. Set the enhanced mode:
Push **SETUP** (front-panel)→**Run Mode** (bottom)→**Enhanced** (side).

- d. Load the AMP1.SEQ file.

Refer to *Loading Files* on page 4–10 for file loading procedures.

3. Push the **RUN** and **CH1** output buttons.

The LEDs above the RUN button and CH1 output connector are on.

4. Verify amplitude accuracy:

- a. Do the following substeps to set the AWG400-Series amplitude and confirm the offset setting:

- Push **VERTICAL MENU** (front-panel)→**Amplitude** (side).
- Push **0**, **.**, **0**, **2**, and **ENTER** keys in this order or turn the general purpose knob to set the amplitude to 0.02 V.
- Verify that the offset setting display on the Offset side button is 0.000 V by pushing offset side button.

If the offset display is not set correctly, push the **Offset** side button, **0**, and the **ENTER** key in this order.

- b. Do the following substeps to verify the amplitude accuracy of a 20 mV amplitude setting:

- Write down the DMM reading as a positive voltage.
- Push the **FORCE EVENT** button.
- Write down the DMM reading as a negative voltage.
- Verify that the positive minus negative voltages fall within $20 \text{ mV} \pm 2.3 \text{ mV}$.

- c. Push **0**, **.**, **2**, and **ENTER** keys in this order or turn the general purpose knob to set the amplitude to 0.200 V.

- d. Do the following to verify the amplitude accuracy of 200 mV amplitude setting:

- Push the **FORCE EVENT** button.
- Write down the DMM reading as a positive voltage.
- Push the **FORCE EVENT** button.
- Write down the DMM reading as a negative voltage.
- Verify that the positive minus negative voltages fall within $200 \text{ mV} \pm 5 \text{ mV}$.

- e. Push the **2** and the **ENTER** keys in this order or turn the general purpose knob to set the amplitude to 2 V.
 - f. Do the following substeps to verify the amplitude accuracy of a 2 V amplitude setting:
 - Push the **FORCE EVENT** button.
 - Write down the DMM reading as a positive voltage.
 - Push the **FORCE EVENT** button.
 - Write down the DMM reading as a negative voltage.
 - Verify that the positive minus negative voltages fall within $2\text{ V} \pm 0.032\text{ V}$.
 - g. Push the **5** and the **ENTER** keys in this order or turn the general purpose knob to set the amplitude to 5 V.
 - h. Do the following substeps to verify the amplitude accuracy of a 5 V amplitude setting:
 - Push the **FORCE EVENT** button.
 - Write down the DMM reading as a positive voltage.
 - Push the **FORCE EVENT** button.
 - Write down the DMM reading as a negative voltage.
 - Verify that the positive minus negative voltages fall within $5\text{ V} \pm 0.077\text{ V}$.
5. Do the following substeps to change the connection to verify CH2:
- Push the **RUN** (front) button and **CH1 OUTPUT** (front) button to turn the output off.
The LEDs above RUN button and CH1 OUTPUT button are off.
 - Disconnect the terminator and cable from the CH1 output connector and connect to the CH2 output connector.
6. Repeat step 2 through step 5 for CH2 and CH3 outputs.
7. Push the CHx OUTPUT button you have just verified to turn the CHx LED off.

**Check Offset Accuracy
(Instrument other than
option 05)**

The following procedure verifies the Offset Accuracy.

1. Use the test hookup and settings shown in Figure 4–15 on page 4–37.
2. Follow the substeps to set the AWG400-Series and load the waveform file.
 - a. Push **UTILITY** (front-panel)→**System** (bottom)→**Factory Reset** (side)→**OK** (side).
 - b. Select the channel:
Push the desired channel button **CHx** (left side of the front panel) you want to verify.
 - c. Load the OFFSET.WFM file.

Refer to *Loading Files* on page 4–10 for file loading procedures.

- d. Set amplitude to 0.02 V:
 - Push **VERTICAL MENU** (front-panel)→**Amplitude** (side)
 - Push **0**, **.**, **0**, **2**, and **ENTER** keys in this order .
3. Push the **RUN** (front-panel) and **CH1 OUTPUT** (front-panel) buttons.
The LEDs above the RUN button and CH1 output connector are on.
 - Verify that $\overline{\text{CH1}}$ output is off:
If the $\overline{\text{CH1}}$ output is on, push **CH1 OUTPUT** button to turn it off.
4. Do the following substeps to set the AWG400-Series offset:
 - a. Set offset to 0 V:
 - Push the **Vertical Menu** (front-panel)→ **Offset** (side button).
 - Push **0**, and **ENTER** keys in this order.
 - b. Verify that the reading on the DMM falls within $0\text{ V} \pm 10\text{ mV}$.
 - c. Push **1**, and **ENTER** keys in this order to change the AWG400-Series offset to 1 V.
 - d. Verify that the reading on the DMM falls within $1\text{ V} \pm 0.020\text{ V}$.
 - e. Push **-**, **1**, and **ENTER** keys in this order to change the AWG400-Series offset to -1 V.
 - f. Verify that the reading on the DMM falls within $-1\text{ V} \pm 0.020\text{ V}$.
5. Do the following substeps to change the connection to verify $\overline{\text{CH1}}$:
 - Push the **RUN** (front) button and **CH1 OUTPUT** (front) button to turn the output off.

The LEDs above RUN button and CH1 OUTPUT button are off.

- Disconnect the terminator and cable from the CH1 output connector and connect to the $\overline{\text{CH1}}$ output connector.
- 6. Repeat step 3 through step 5 for $\overline{\text{CH1}}$ output.
- 7. Repeat step 2 through step 6 for CH2, $\overline{\text{CH2}}$, CH3, and $\overline{\text{CH3}}$ outputs.
- 8. Push $\overline{\text{CHx}}$ OUTPUT button that you have just verified to turn the $\overline{\text{CHx}}$ LED off.

Check Offset Accuracy (Instrument with option 05)

The following procedure verifies the Offset Accuracy.

1. Use the test hookup and settings shown in Figure 4–15 on page 4–37.
2. Set up the AWG400-Series, and load the waveform file:
 - a. Push **UTILITY** (front-panel)→**System** (bottom)→**Factory Reset** (side)→**OK** (side).
 - b. Select the channel:
Push the desired channel button **CHx** (left side of the front-panel) you want to verify.
 - c. Load the OFFSET.WFM file.

Refer to *Loading Files* on page 4–10 for file loading procedures.

- d. Set amplitude to 0.02 V:
 - Push **VERTICAL MENU** (front-panel)→**Amplitude** (side)
 - Push **0**, **.**, **0**, **2**, and **ENTER** keys in this order.
3. Push the **RUN** and **CH1** output buttons.

The LEDs above the RUN button and CH1 output connector are on.

4. Do the following substeps to set the AWG400-Series offset:
 - a. Set offset to 0 V:
 - Push the **Vertical Menu** (front-panel)→ **Offset** (side button).
 - Push **0** and **ENTER** keys in this order.
 - b. Verify that the reading on the DMM falls within $0 \text{ V} \pm 10 \text{ mV}$.
 - c. Push **1** and **ENTER** keys in this order to change the AWG400-Series offset to 1 V.
 - d. Verify that the reading on the DMM falls within $1 \text{ V} \pm 0.020 \text{ V}$.
 - e. Push **-**, **1**, and **ENTER** keys in this order to change the AWG400-Series offset to -1 V.

- f. Verify that the reading on the DMM falls within $-1\text{ V} \pm 0.020\text{ V}$.
 - g. Push **2**, **.**, **5**, and **ENTER** keys in this order to change the AWG400-Series offset to 2.5 V.
 - h. Verify that the reading on the DMM falls within $2.5\text{ V} \pm 0.035\text{ V}$.
 - i. Push **-**, **2**, **.**, **5**, and **ENTER** keys in this order to change the AWG400-Series offset to -2.5 V.
 - j. Verify that the reading on the DMM falls within $-2.5\text{ V} \pm 0.035\text{ V}$.
5. Do the following substeps to change the connection to verify the CH2:
- Push the **RUN** (front) button and **CH1 OUTPUT** (front) button to turn the output off.
The LEDs above RUN button and CH1 OUTPUT button are off.
 - Disconnect the terminator and cable from the CH1 output connector and connect to the CH2 output connector.
6. Repeat step 3 through step 5 for CH2 and CH3 outputs.
7. Push CHx OUTPUT button that you have just verified to turn the CHx LED off.

Amplitude, Offset Accuracy and Rise Time Tests (Direct DA Out)

These procedures verify the accuracy of the AWG400-Series direct waveform outputs: amplitude and offset.

NOTE. You need to verify $CH1$ and $\overline{CH1}$ outputs for AWG410, the $CH1$, $\overline{CH1}$, $CH2$, and $\overline{CH2}$ outputs for AWG420, and the $CH1$, $\overline{CH1}$, $CH2$, $\overline{CH2}$, $CH3$ and $\overline{CH3}$ outputs for AWG430. If you have option 05, you do not have to verify \overline{CHx} .

When you verify one of the outputs, turn off the other outputs.

NOTE. The amplitude and offset accuracy verifications are performed as a continuous test. The offset accuracy test uses the same control settings as the amplitude test.

Check Amplitude and DC Offset (Instrument with option 05)

| | |
|---------------------------|---|
| Equipment required | A 50 Ω BNC coaxial cable, a 50 Ω precision terminator, BNC (female)-to-dual banana adapter, and a digital multimeter (DMM). |
| Prerequisites | The AWG400-Series Arbitrary Waveform Generator must meet the prerequisites listed on page 4–8. |

1. Do the following steps to install the test hookup and set the test equipment controls (same hookup used by the Amplitude and Offset Accuracy Test (Normal Out) beginning on page 4–37):
 - a. Use a 50 Ω BNC coaxial cable, a 50 Ω precision terminator, and a BNC-to-dual banana adapter to connect the AWG400-Series **CH1** output to the DMM input connector (see Figure 4–17).

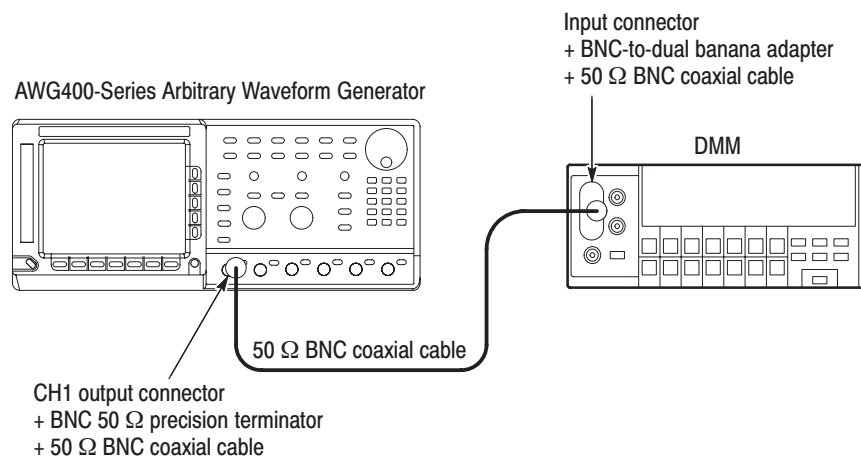

Figure 4–17: Direct DA output amplitude accuracy initial test hookup

- b. Set the DMM controls as follows:

| | |
|-------------|-------|
| Mode | VDC |
| Range | Auto |
| Input | Front |

2. Set up the AWG400-Series, and load the waveform file:
 - a. Push **UTILITY** (front-panel)→**System** (bottom)→**Factory Reset** (side)→**OK** (side).
 - b. Select the channel:
Push the desired channel button **CHx** (left side of the front panel) you want to verify.
 - c. Set the enhanced mode:
Push **SETUP** (front-panel)→**Run Mode** (bottom)→**Enhanced** (side).
 - d. Push **VERTICAL MENU** (front-panel)→**Output** (side)→**Direct** (side).
 - e. Load the AMP2.SEQ file.

Refer to *Loading Files* on page 4–10 for file loading procedures.

3. Push the **RUN** and **CH1 OUTPUT** buttons.

The LEDs above the RUN button and CH1 output connector are on.

4. Do the following substeps to verify the direct DA amplitude accuracy of a 0.5 V amplitude setting:
 - a. Verify amplitude accuracy:
 - Write down the DMM reading as a positive voltage.
 - Push the **FORCE EVENT** button.
 - Write down the DMM reading as a negative voltage.
 - Verify that the positive minus negative voltages fall within 500 mV ± 9.5 mV.
 - b. Follow the substeps below to verify the DC offset:
 - Push the **FORCE EVENT** button.
 - Verify that the reading from the oscilloscope display is about 0 V ±10 mV.

5. Do the following substeps to change the connection to verify the CH2:

- Push the **RUN** (front) button and **CH1 OUTPUT** (front) button to turn the output off.

The LEDs above RUN button and CH1 OUTPUT button are off.

- Disconnect the terminator and cable from the CH1 output connector, and connect to the CH2 output connector.
- 6. Repeat step 3 through step 5 for CH2 and CH3 output.
- 7. Push CHx OUTPUT button that you have just verified to turn the CHx LED off.

Check Amplitude and DC Offset (Instrument with option 05)

| | |
|---------------------------|---|
| Equipment required | A 50 Ω BNC coaxial cable, a 50 Ω precision terminator, BNC (female)-to-dual banana adapter, and a digital multimeter (DMM). |
| Prerequisites | The AWG400-Series Arbitrary Waveform Generator must meet the prerequisites listed on page 4–8. |

1. Do the following steps to install the test hookup and set the test equipment controls (same hookup used by the Amplitude and Offset Accuracy Test (Normal Out) beginning on page 4–37):
 - a. Use a 50 Ω BNC coaxial cable, a 50 Ω precision terminator, and a BNC-to-dual banana adapter to connect the AWG400-Series **CH1** output to the DMM input connector (see Figure 4–18).

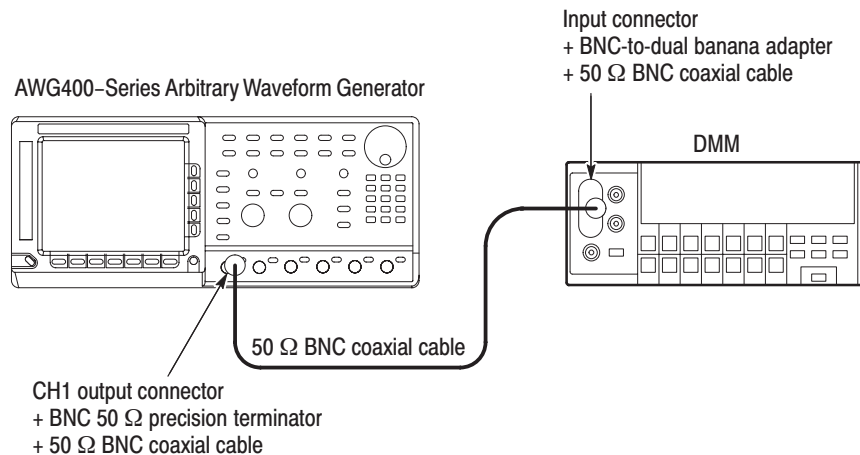

Figure 4–18: Direct DA output amplitude accuracy initial test hookup

- b. Set the DMM controls as follows:

Mode VDC
 Range Auto
 Input Front

2. Set up the AWG400-Series and waveform file load:
 - a. Push **UTILITY** (front-panel)→**System** (bottom)→**Factory Reset** (side)→**OK** (side).
 - b. Select the channel:
Push the desired channel button **CHx** (left side of the front-panel) you want to verify.
 - c. Set the enhanced mode:
Push **SETUP** (front-panel)→**Run Mode** (bottom)→**Enhanced** (side).
 - d. Push **VERTICAL MENU** (front-panel)→**Output** (side)→**Direct** (side).
 - e. Load the AMP2.SEQ file.

Refer to *Loading Files* on page 4–10 for file loading procedures.

3. Push the **RUN** and **CH1 OUTPUT** buttons.

The LEDs above the RUN button and CH1 output connector are on.

4. Do the following substeps to verify the direct DA amplitude accuracy of a 0.5 V amplitude setting:

- a. Verify amplitude accuracy:
 - Write down the DMM reading as a positive voltage.
 - Push the **FORCE EVENT** button.
 - Write down the DMM reading as a negative voltage.
 - Verify that the positive minus negative voltages fall within $500\text{ mV} \pm 9.5\text{ mV}$.
- b. Follow the substeps below to verify the DC offset:
 - Push the **FORCE EVENT** button.
 - Verify that the reading from the oscilloscope display is about $0\text{ V} \pm 10\text{ mV}$.

5. Do the following substeps to change the connection to verify the CH2:

- Push the **RUN** (front) button and **CH1 OUTPUT** (front) button to turn the output off.
The LEDs above RUN button and CH1 OUTPUT button are off.
- Disconnect the terminator and cable from the CH1 output connector, and connect to the CH2 output connector.

6. Repeat the step 3 through step 5 for CH2 and CH3 output.

7. Push CHx OUTPUT button you have just verified to turn the CHx LED off.

**Check Pulse Rise Time
(Instrument other than
option 05)**

| | |
|---------------------------|--|
| Equipment required | A 50 Ω BNC coaxial cable and an oscilloscope (TDS7104). |
| Prerequisites | The AWG400-Series Arbitrary Waveform Generator must meet the prerequisites listed on page 4–8. |

1. Do the following steps to install the test hookup and set the test equipment controls:
 - a. Use the 50 Ω BNC coaxial cable to connect the AWG400-Series CH1 output connector to the oscilloscope CH1 input connector (see Figure 4–19).

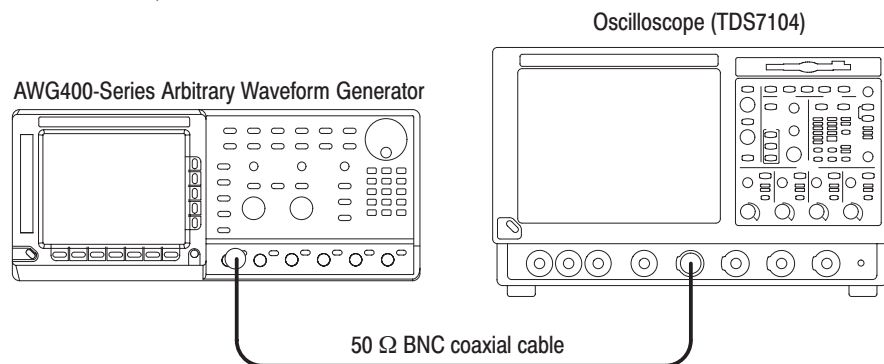

Figure 4–19: Direct DA output pulse rise time initial test hookup

- b. Set the oscilloscope controls as follows:

| | |
|-----------------|------------|
| Vertical | CH1 |
| CH1 scale | 100 mV/div |
| Horizontal | |
| Sweep | 1 ns/div |
| Trigger | |
| Source | CH1 |
| Slope | Positive |
| Level | 0 V |
| Mode | Auto |

NOTE. The pulse rise time tests use the AWG400-Series control settings that have been used in the amplitude and DC offset tests. You do not need to initialize the AWG400-Series controls.

2. Set up the AWG400-Series, and load the waveform file:
 - a. Select the channel:
Push the desired channel button (**CHx**) (left side of the front-panel) you want to verify.

- b. Load the PULSE.WFM file.

Refer to *Loading Files* on page 4–10 for file loading procedures.

- c. Set the continuous mode:
Push **SETUP** (front-panel)→**Run Mode** (bottom)→**Continuous** (side).
- d. Change the AWG400-Series controls as follows:
 - Push **VERTICAL MENU** (bottom)→**Amplitude** (side).
 - Push **0**, **.**, **5** and **ENTER** keys in this order or turn the general purpose knob to set the amplitude to 0.5 V.
 - Verify that the Direct DA out is selected.
If not, push **Output** (side)→**Direct** (side).
- e. Push the **RUN** and **CH1** output buttons.

The LEDs above the RUN button and CH1 output connectors are on.

3. Verify that the rise time of the pulse waveform displayed on the oscilloscope is equal to or less than 3 ns.
4. Do the following substeps to change the connection to verify the $\overline{\text{CH1}}$:
 - a. Push the **RUN** (front) button and **CH1 OUTPUT** (front) button to turn the output off.

The LEDs above RUN button and CH1 OUTPUT button are off.
 - b. Disconnect the terminator and cable from the CH1 output connector and connect to the $\overline{\text{CH1}}$ output connector.
5. Repeat step 2e through step 4 for $\overline{\text{CH1}}$ output.
6. Repeat step 2 through step 5 for CH2, $\overline{\text{CH2}}$, CH3, and $\overline{\text{CH3}}$ outputs.
7. Remove test hookup.
8. Push $\overline{\text{CHx}}$ OUTPUT button that you have just verified to turn the CHx LED off.
9. Push the **RUN** (front) button to turn the output off.

The LEDs above RUN button are off.

**Check Pulse Rise Time
(Instrument with option
05)**

| | |
|---------------------------|--|
| Equipment required | A 50 Ω BNC coaxial cable and an oscilloscope (TDS7104). |
| Prerequisites | The AWG400-Series Arbitrary Waveform Generator must meet the prerequisites listed on page 4–8. |

1. Do the following steps to install the test hookup and set the test equipment controls:
 - a. Use the 50 Ω BNC coaxial cable to connect the AWG400-Series CH1 output connector to the oscilloscope CH1 input connector (see Figure 4–20).

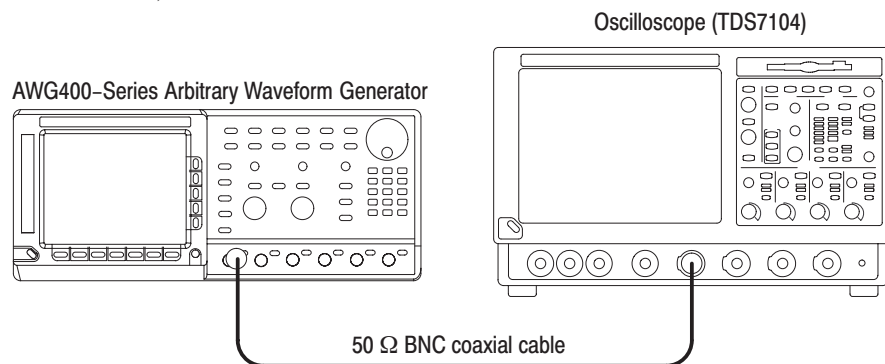

Figure 4–20: Direct DA output pulse rise time initial test hookup

- b. Set the oscilloscope controls as follows:

| | |
|-----------------|------------|
| Vertical | CH1 |
| CH1 scale | 100 mV/div |
| Horizontal | |
| Sweep | 1 ns/div |
| Trigger | |
| Source | CH1 |
| Slope | Positive |
| Level | 0 V |
| Mode | Auto |

NOTE. The pulse rise time tests use the AWG400-Series control settings that have been used in the amplitude and DC offset tests. You do not need to initialize the AWG400-Series controls.

2. Set up the AWG400-Series and load the waveform file:
 - a. Select the channel:
Push the desired channel button **CHx** (left side of the front-panel) you want to verify.

- b. Load the PULSE.WFM file.

Refer to *Loading Files* on page 4–10 for file loading procedures.

- c. Set the continuous mode:
Push **SETUP** (front-panel)→**Run Mode** (bottom)→**Continuous** (side).
- d. Change the AWG400-Series controls as follows:
 - Push **SETUP** (front-panel)→**Vertical** (bottom)→**Amplitude** (side).
 - Push **0**, **.**, **5** and **ENTER** keys in this order or turn the general purpose knob to set the amplitude to 0.5 V.
 - Verify that the Direct DA out is selected.
If not, push **Output** (side)→**Direct** (side).
- e. Push the **RUN** (front) button and **CH1 OUTPUT** (front) button to make the output on.

The LEDs above the RUN button and CH1 output connectors are on.

3. Verify that the rise time of the pulse waveform displayed on the oscilloscope is equal to or less than 3 ns.
4. Do the following substeps to change the connection to verify the CH2:
 - a. Push the **RUN** (front) button and **CH1 OUTPUT** (front) button to turn the output off.

The LEDs above RUN button and CH1 OUTPUT button are off.
 - b. Disconnect the terminator and cable from the CH1 output connector, and connect to the CH2 output connector.
5. Repeat the step 2 through step 4 for CH2 and CH3 output.
6. Remove test hookup:
 - a. Push **CHx OUTPUT** (front) button you have just verified to turn the CHx LED off.
 - b. Push the **RUN** (front) button to turn the output off.

The LEDs above RUN button are off.

Step Response Tests (normal out)

This procedure verifies the pulse response characteristics of the AWG400-Series output waveforms at amplitudes of 1 V and 2 V.

NOTE. You need to verify $\overline{CH1}$ and $\overline{CH1}$ outputs for AWG410, the $\overline{CH1}$, $\overline{CH1}$, $\overline{CH2}$, and $\overline{CH2}$ outputs for AWG420, and the $\overline{CH1}$, $\overline{CH1}$, $\overline{CH2}$, $\overline{CH2}$, $\overline{CH3}$ and $\overline{CH3}$ outputs for AWG430. If you have option 05, you do not have to verify \overline{CHx} .

When you verify one of the outputs, turn off the other outputs.

Check Step Response (Instrument other than option 05)

| | |
|---------------------------|--|
| Equipment required | A 50 Ω BNC coaxial cable and an oscilloscope (TDS7104). |
| Prerequisites | The AWG400-Series Arbitrary Waveform Generator must meet the prerequisites listed on page 4–8. |

1. Do the following steps to install the test hookup and set the test equipment controls:
 - a. Use the 50 Ω BNC coaxial cable to connect the AWG400-Series CH1 output connector to the oscilloscope CH1 input connector (see Figure 4–21).

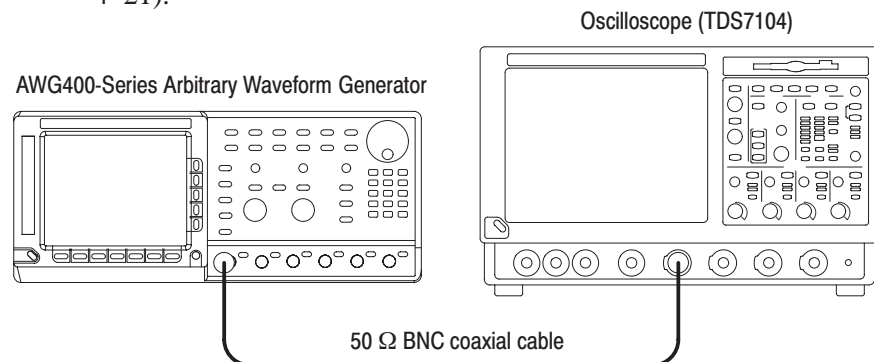

Figure 4–21: Step response initial test hookup

- b. Set the oscilloscope controls as follows:

| | |
|---------------------------|-------------|
| Vertical | CH1 |
| CH1 coupling | DC |
| CH1 scale | 0.2 V/div |
| CH1 input impedance | 50 Ω |
| Horizontal | |
| Sweep | 1 ns/div |

| | |
|----------------|----------|
| Trigger | |
| Source | CH1 |
| Coupling | DC |
| Slope | Positive |
| Level | 0 V |
| Mode | Auto |

2. Set up the AWG400-Series, and load the waveform file:
 - a. Reset the instrument:
Push **UTILITY** (front-panel)→**System** (bottom)→**Factory Reset** (side)→**OK** (side).
 - b. Select the channel:
Push the desired channel button **CHx** (left side of the front panel) you want to verify.
 - c. Load the PULSE.WFM file.

Refer to *Loading Files* on page 4–10 for file loading procedures.
 - d. Set the continuous mode:
Push **SETUP** (front-panel)→**Run** (bottom)→**Continuous** (side).
 - Push **VERTICAL** (bottom).
 - Verify the Output mode is Normal:
If Normal is not selected in Output (side) menu, push **Vertical Menu**→**Output** (side) to select Normal.
3. Set the CH1 output to enable:
Push the **RUN Mode** (front) button and **CH1 OUTPUT** (front) button to turn on the LEDs for RUN and CH1.
 - Verify that the $\overline{\text{CH1}}$ output is off:
If the CH1 LED is on, push $\overline{\text{CH1}}$ **OUTPUT** (front) to turn the LED off.
4. Verify the step response at 1 V amplitude by following the substeps below:
 - a. Verify that the rise time of the waveform displayed on the oscilloscope from 10% to 90% point is equal to or less than 4 ns.
 - b. Verify the aberration by doing the following:
 - Set the oscilloscope:

| | |
|-------------|-----------|
| Horizontal | |
| Sweep | 10 ns/div |

- Verify that the aberration of the displayed waveform on the oscilloscope screen is within $\pm 7\%$.
- c. Verify the flatness by doing the following:
 - Set the oscilloscope:

Horizontal
Sweep 200 ns/div
 - Verify that the flatness of the displayed waveform on the oscilloscope is within $\pm 3\%$ after 50 ns from the rising edge.
- 5. Verify the step response at 2 V amplitude by following the substeps below:
 - a. Set the oscilloscope controls as follows:

Vertical CH1
CH1 scale 0.5 V/div
 - b. Set the AWG400-Series control as follows:
 - Push **SETUP** (front-panel)→**Vertical** (bottom)→**Amplitude** (side).
 - Push **2** and **ENTER** keys in this order or turn the general purpose knob to set the amplitude to 2 V.
 - c. Repeat step 4a to 4c to verify the following parameters:
 - Risetime 4 ns maximum
 - Aberration $\pm 10\%$ maximum
 - Flatness $\pm 3\%$ maximum
- 6. Do the following substeps to change the connection to verify the $\overline{\text{CH1}}$:
 - a. Push **Run**→**CH1 OUTPUT** (front) button to turn off the CH1 LED.
 - b. Disconnect the $50\ \Omega$ BNC cable from the CH1 output connector and connect it to the $\overline{\text{CH1}}$ output connector.
- 7. Repeat steps 3 through 6 to verify $\overline{\text{CH1}}$.
- 8. Repeat the procedure from steps 2 to 7 to verify CH2, $\overline{\text{CH2}}$, CH3, and $\overline{\text{CH3}}$.
- 9. Push $\overline{\text{CHx}}$ **OUTPUT** to turn off the $\overline{\text{CHx}}$ LED.
- 10. Push **RUN** (front) to turn off the RUN LED.
 - a. Disconnect all the cables.

**Check Step Response
(Instrument with
option 05)**

| | |
|---------------------------|--|
| Equipment required | A 50 Ω BNC coaxial cable and an oscilloscope (TDS7104). |
| Prerequisites | The AWG400-Series Arbitrary Waveform Generator must meet the prerequisites listed on page 4–8. |

1. Do the following steps to install the test hookup and set the test equipment controls:
 - a. Use the 50 Ω BNC coaxial cable to connect the AWG400-Series CH1 output connector to the oscilloscope CH1 input connector (see Figure 4–22).

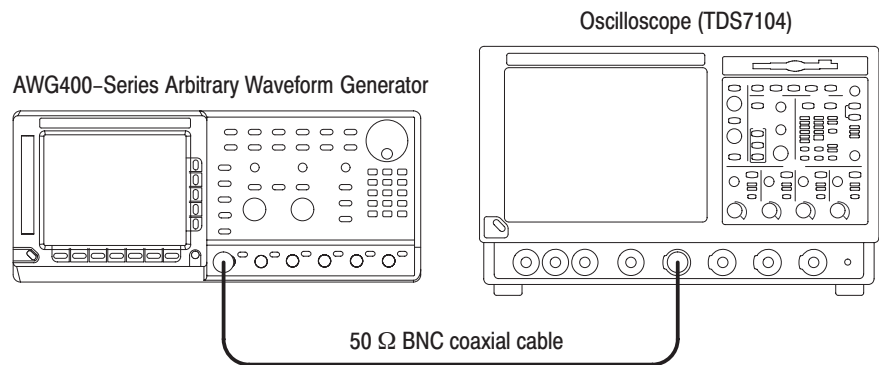

Figure 4–22: Step response initial test hookup

- b. Set the oscilloscope controls as follows:

| | |
|---------------------|-----------|
| Vertical | CH1 |
| CH1 coupling | DC |
| CH1 scale | 0.2 V/div |
| CH1 input impedance | 50 Ω |
| Horizontal | |
| Sweep | 1 ns/div |
| Trigger | |
| Source | CH1 |
| Coupling | DC |
| Slope | Positive |
| Level | 0 V |
| Mode | Auto |

2. Set up the AWG400-Series and load the waveform file:
 - a. Reset the instrument:
Push **UTILITY** (front-panel)→**System** (bottom)→**Factory Reset** (side)→**OK** (side).
 - b. Select the channel:
Push the desired channel button **CHx** (left side of the front-panel) you want to verify.
 - c. Load the PULSE.WFM file:
Refer to *Loading Files* on page 4–10 for file loading procedures.
 - d. Set the continuous mode:
Push **SETUP** (front-panel)→**Run Mode** (bottom)→**Continuous** (side).
 - Push the **VERTICAL** (bottom) button.
 - Verify that the Output mode is Normal:
If Normal is not selected in the **Output** (side) menu, push **Vertical Menu**→**Output** (side) to select Normal.
3. Set the CH1 output to enable:
Push the **RUN** (front) button and **CH1 OUTPUT** (front) button to turn on the LEDs of RUN and CH1.
 - Verify that the CH1 output is off:
If the CH1 LED is on, push **CH1 OUTPUT** (front) to turn the LED off.
4. Verify the step response at 1 V amplitude by following the substeps below:
 - a. Verify that the rise time of the waveform displayed on the oscilloscope from 10% to 90% point is equal to or less than 5 ns.
 - b. Verify that the aberration by doing the following:
 - Set the oscilloscope:

Horizontal
Sweep 10 ns/div
 - Verify that the aberration of the displayed waveform on the oscilloscope screen is within $\pm 7\%$.

- c. Verify that the flatness by doing the following:

- Set the oscilloscope:

Horizontal

Sweep 200 ns/div

- Verify that the flatness of the displayed waveform on the oscilloscope is within $\pm 3\%$ after 50 ns from the rising edge.

5. Verify the step response at 5 V amplitude by following the substeps below:

- a. Set the oscilloscope controls as follows:

Vertical CH1

CH1 scale 1 V/div

- b. Set the AWG400-Series control as follows:

- Push **SETUP** (front-panel)→**Vertical** (bottom)→**Amplitude** (side).
- Push **5** and **ENTER** keys in this order or turn the general purpose knob to set the amplitude to 5 V.

- c. Repeat steps 4a through 4c to verify below:

- Risetime 5 ns maximum
- Aberration $\pm 10\%$ maximum
- Flatness $\pm 3\%$ maximum

6. Do the following substeps to change the connection to verify the CH2:

- a. Push the **CH1 OUTPUT** (front) button to turn off the CH1 LED.
- b. Disconnect the 50 Ω BNC cable from the CH1 output connector and connect it to the CH2 output connector.

7. Repeat step 2 through step 6 and verify the CH2 and CH3.

8. Push **CHx OUTPUT** to turn off the **CHx** LED.

9. Push **RUN** (front) to turn off the RUN LED.

Internal Trigger Tests

These procedures verify internal trigger function of the AWG400-Series Arbitrary Waveform Generator.

| | |
|---------------------------|--|
| Equipment required | A 50 Ω BNC coaxial cable and an oscilloscope (TDS7104). |
| Prerequisites | The AWG400-Series Arbitrary Waveform Generator must meet the prerequisites listed on page 4–8. |

Do the following steps to install the test hookup and set the test equipment controls:

1. Test hookup and setting.
 - a. Use the 50 Ω BNC coaxial cable to connect the AWG400-Series Arbitrary Waveform Generator **CH1** output connector to the oscilloscope CH1 input connector (see Figure 4–23).

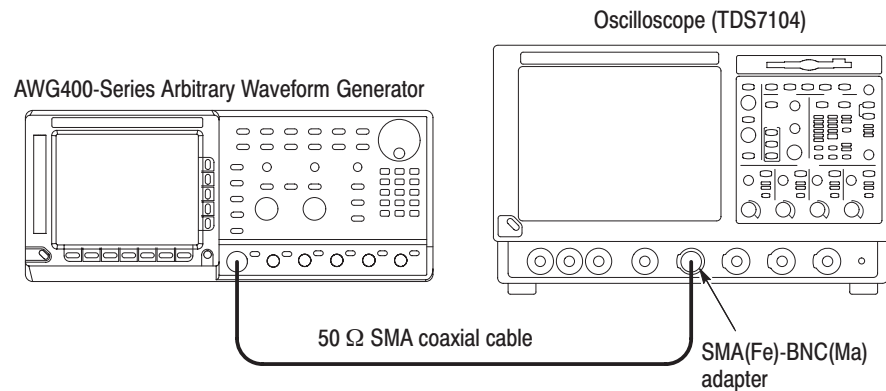

Figure 4–23: Internal trigger initial test hookup

- b. Set the oscilloscope controls as follows:

| | |
|---------------------------|-------------|
| Vertical | CH1 |
| CH1 coupling | DC |
| CH1 scale | 0.5 V/div |
| CH1 input impedance | 50 Ω |
| Horizontal | |
| Sweep | 1 ms/div |
| Trigger | |
| Source | CH1 |
| Coupling | DC |

| | |
|-------------|----------|
| Slope | Positive |
| Level | 0.2 V |
| Mode | Auto |

2. Set up the AWG400-Series, and load the waveform file.
 - a. Push **UTILITY** (front-panel)→**System** (bottom)→**Factory Reset** (side)→**OK** (side).
 - b. Load the MODE.WFM file.
Refer to *Loading Files* on page 4–10 for file loading procedures.
 - c. Push **SETUP** (front-panel)→**Run Mode** (bottom)→**Triggered** (side).
 - d. Push **Horizontal** (bottom)→**Clock** (side)→**1, 0**, and **M** (SHIFT+7).
The clock is set to 10.0 MS/s.
 - e. Do the following substeps to set the trigger interval:
 - Push **SETUP** (front-panel)→**Trigger** (bottom)→**Source** (side)→**Internal** (side).
 - Push the **Interval** side button.
 - Push **1** and **m** (SHIFT+9) keys in this order to set the trigger interval to 1 ms.
The numeric value of 1m is entered.
3. Push the **RUN** and **CH1 OUT** buttons.
The LEDs above the **RUN** button and CH1 output connectors are on. If the **CH1** LED is on, push **CH1 OUTPUT** to turn it off.
4. Verify that there is a single sinewave cycle displayed at 1 ms intervals.
5. Push **2** and **m** (SHIFT+9) keys in this order to set the trigger interval to 2 ms.
The trigger interval is changed to a value of 2 ms.
6. Verify that the period between the waveform displayed on the oscilloscope is two horizontal divisions.
7. Push the **CH1 OUT** button to turn off the CH1 LED.
8. Push the **RUN** button to turn off the RUN LED.
9. Disconnect all the cable.

Trigger Input Tests

These procedures verify the trigger level accuracy of the AWG400-Series Arbitrary Waveform Generator.

| | |
|---------------------------|--|
| Equipment required | A BNC T adapter, three 50 Ω BNC coaxial cable, a function generator, and an oscilloscope. |
| Prerequisites | The AWG400-Series Arbitrary Waveform Generator must meet the prerequisites listed on page 4–8. |

1. Do the following steps to install the test hookup and set the test equipment controls:
 - a. Use a 50 Ω BNC coaxial cable to connect the AWG400-Series CH1 output connector to the oscilloscope CH1 input connector.
 - b. Connect a BNC T adapter to the TRIG IN connector, and then use a 50 Ω BNC coaxial cable to connect the BNC T adapter to the oscilloscope CH2 input connector.
 - c. Use a 50 Ω BNC coaxial cable to connect the function generator output to the other end of the BNC T adapter.

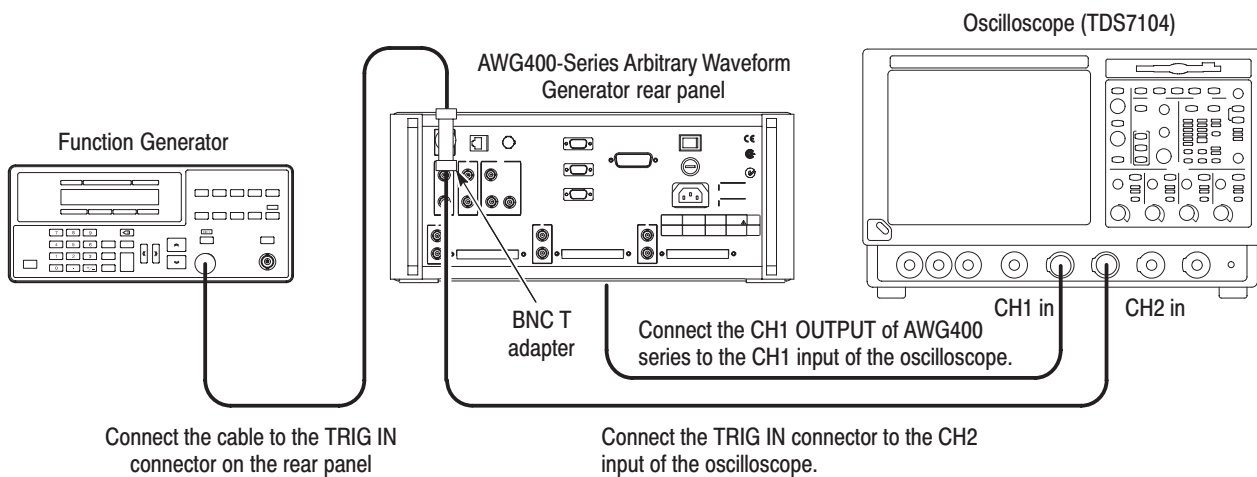

Figure 4–24: Trigger input initial test hookup

- d. Set the oscilloscope controls as follows:

Push the **Default Setup** (front).

| | |
|---------------------------|-----------------|
| Vertical | CH1 and CH2 |
| CH1 coupling | DC |
| CH1 scale | 500 mV/div |
| CH1 input impedance | 50 Ω |
| CH2 scale | 2 V/div |
| CH2 input impedance | 1 M Ω |
| Horizontal | |
| Sweep | 200 μ s/div |
| Trigger | |
| Source | CH1 |
| Coupling | DC |
| Slope | Positive |
| Level | +100 mV |
| Mode | Auto |

- e. Set the function generator as follows:

| | |
|-----------------|--|
| Function | Pulse |
| Mode | Continuous |
| Parameter | |
| Frequency | 100 Hz |
| Amplitude | 1.0 V (2 V in open circuit) |
| Offset | Adjust for a pulse 4.65 V in amplitude referenced to ground |
| Output | Off |

2. Set up the AWG400-Series, and load the waveform file.

- Push **UTILITY** (front-panel)→**System** (bottom)→**Factory Reset** (side)→**OK** (side).
- Push **SETUP** (front-panel)→**Run Mode** (bottom)→**Triggered** (side).
- Load the TRIG.WFM file.

Refer to *Loading Files* on page 4–10 for file loading procedures.

3. Push the **RUN** and **CH1 OUT** buttons.

The LEDs above the RUN button and CH1 output connector are on.

- Verify that the $\overline{\text{CH1 OUTPUT}}$ is off.
If the CH1 LED is on, push $\overline{\text{CH1 OUTPUT}}$ (front-panel) to turn the LED off.

4. Verify the trigger level accuracy at + 5 V by following the substeps below:
 - a. Set the trigger level.
 - Push **SETUP** (front-panel)→**Trigger** (bottom)→**Level** (side).
 - Push **5** and **ENTER** keys in this order.
 - b. Set the offset of the generator.
 - Push generator output **ON**.
 - Push **Cursor**, **<<**, **>>**, **↗**, **↘** keys as the high level of a pulse to be set to 4.65V.
 - c. Verify that no waveform is displayed on the oscilloscope (see Figure 4–25).

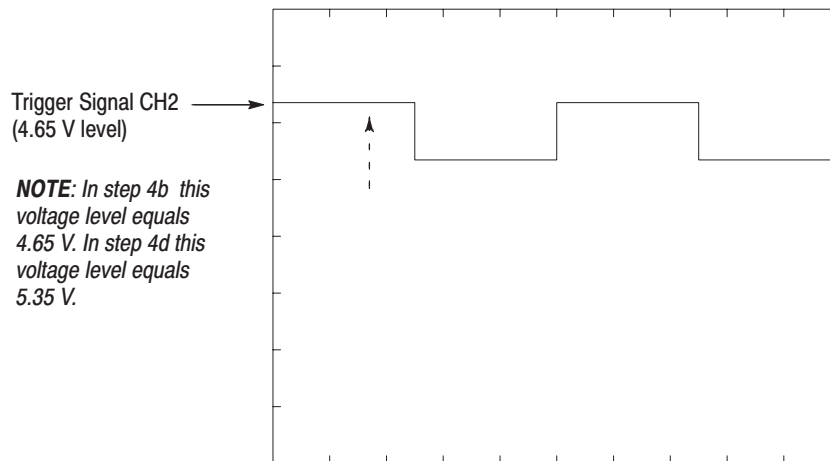

Figure 4–25: Trigger Signal (+5V check1)

- d. Push **Cursor**, **<<**, **>>**, **↗**, **↘** keys as the high level of a pulse to be set to 4.65V.
- e. Verify that a sine wave is displayed on the oscilloscope (see Figure 4–26).

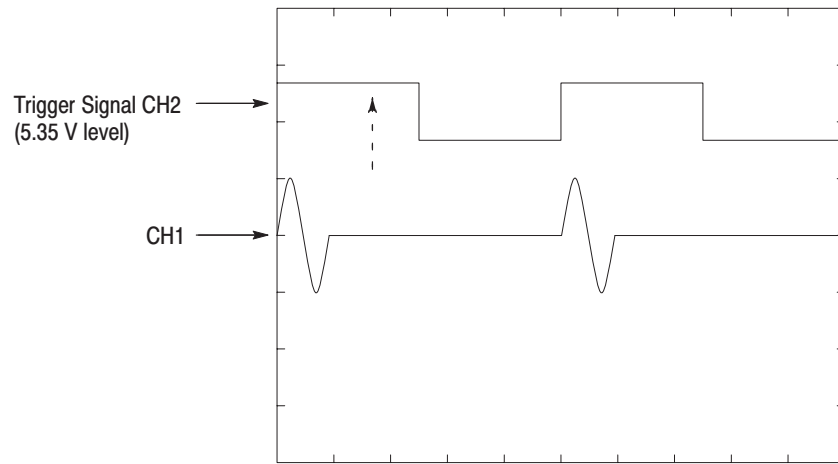

Figure 4-26: Trigger Signal (+5V check2)

5. Verify the trigger level accuracy at -5 V by following the substeps below:
 - a. Set the trigger level of the generator.
 - Push **Level** (side).
 - Push **-**, **5**, and **ENTER** keys in this order.
 - b. Set the offset level of the generator
 - Push **Cursor**, **<<**, **>>**, **▲**, **▼** keys as the low level of a pulse to be set to -4.65 V.
 - c. Verify that no waveform is displayed on the oscilloscope (see Figure 4-27).

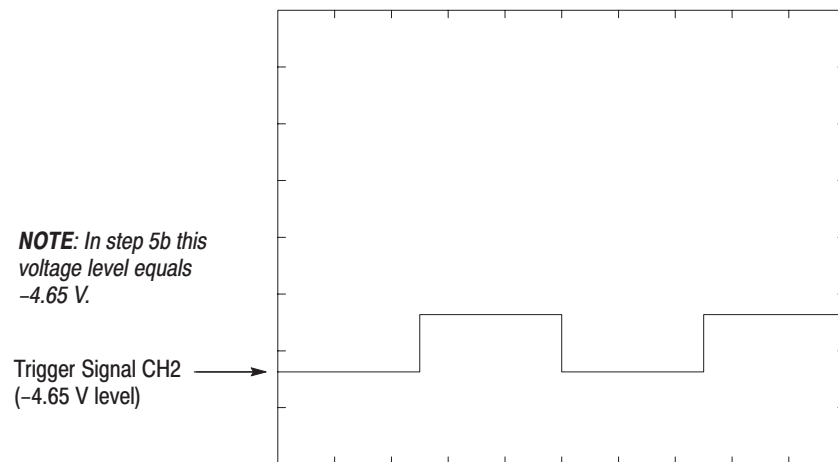

Figure 4-27: Trigger Signal (-5 V check1)

- d. Push Cursor, \ll , \gg , \wedge , \vee keys as the low level of a pulse to be set to -5.35 V.
- e. Verify that a sine wave is displayed on the oscilloscope (see Figure 4–28).

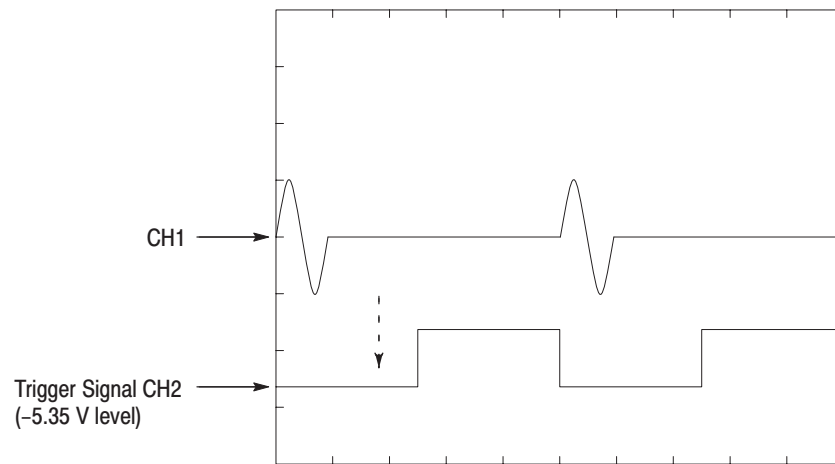

Figure 4–28: Trigger Signal (-5 V check2)

- 6. Push the **RUN** button to turn off the RUN LED.
- 7. Disconnect all the cables.

Event Input and Enhanced Mode Tests

These procedures verify the event input signals and enhanced mode operation.

NOTE. The event input verify with strobe off and the strobe input verify are structured as a continuous test. After Check Event Input with Strobe Off, the next test uses the connections and oscilloscope settings from the previous test.

Check Event Input with Strobe Off

| | |
|---------------------------|---|
| Equipment required | A 50 Ω BNC coaxial cable and a custom-made ground closure. See Figure 4-3 on page 4-9 for the connections. |
| Prerequisites | The AWG400-Series Arbitrary Waveform Generator must meet the prerequisites listed on page 4-8. |

1. Do the following steps to install the test hookup and set the test equipment controls:
 - a. Use a 50 Ω BNC coaxial cable to connect the AWG400-Series **CH1** output connector to the oscilloscope CH1 input connector (see Figure 4-29).

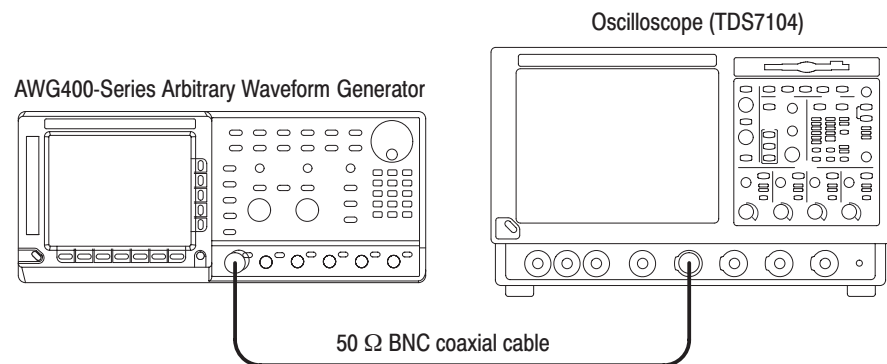

Figure 4-29: Event input and enhanced mode initial test hookup

- b. Connect the ground closure to the EVENT IN connector on the AWG400-Series rear panel.
- c. Set the oscilloscope controls as follows:

| | |
|-------------------------------|-------------|
| Vertical | CH1 |
| CH1 coupling | DC |
| CH1 scale | 0.2 V/div |
| CH1 input impedance | 50 Ω |

| | |
|----------------|----------|
| Horizontal | |
| Sweep | 400 ns |
| Trigger | |
| Source | CH1 |
| Coupling | DC |
| Slope | Positive |
| Level | +100 mV |
| Mode | Auto |

2. Set all the switches of the ground closure to open.
3. Set up the AWG400-Series, controls and load the sequence file:
 - a. Push **UTILITY** (front-panel)→**System** (bottom)→**Factory Reset** (side)→**OK** (side).
 - b. Load the PT_EVENT.SEQ file.

Refer to *Loading Files* on page 4–10 for file loading procedures.

- c. Push **SETUP** (front-panel)→**Run Mode** (bottom)→**Enhanced** (side) to set the enhanced mode.
4. Push the **RUN** and **CH1 OUT** buttons.

The LEDs above the RUN button and CH1 output connector are on.

 - Verify that the $\overline{\text{CH1 OUTPUT}}$ is off.
If the CH1 LED is on, push **CH1 OUTPUT** (front-panel) to turn the LED off.
5. Verify the EVENT IN connector pin 0 input by doing the following substeps:
 - a. Verify that the waveform being displayed on the oscilloscope is about the same amplitude as shown in Figure 4–30.

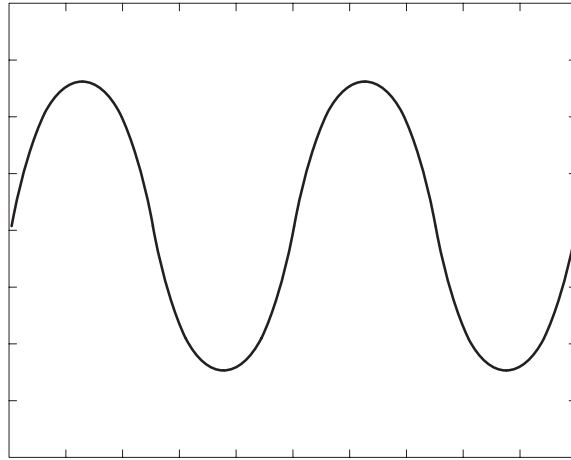

Figure 4-30: Waveform while all ground disclosure switches are open

- b. Close the SW1 of the ground closure to generate an event signal on the EVENT IN connector pin 0.
- c. Verify that the oscilloscope displays the waveform as shown in Figure 4-31 and that the waveform is about half the amplitude as that shown in Figure 4-30.

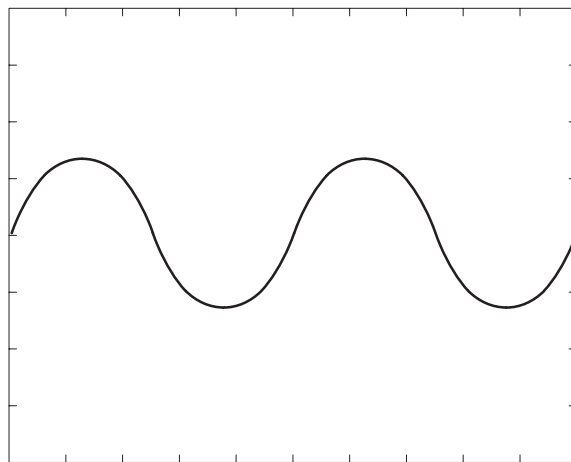

Figure 4-31: Waveform output when the SW1 is closed

- d. Open SW1 of the ground closure.
- e. Verify that the oscilloscope displays the waveform in Figure 4-30.

6. Verify the EVENT IN connector pin 1 input by following the substeps below:
 - a. Close SW2 of the ground closure to generate an event signal on the EVENT IN connector pin 1.
 - b. Verify that the oscilloscope displays the waveform as shown in Figure 4–32.

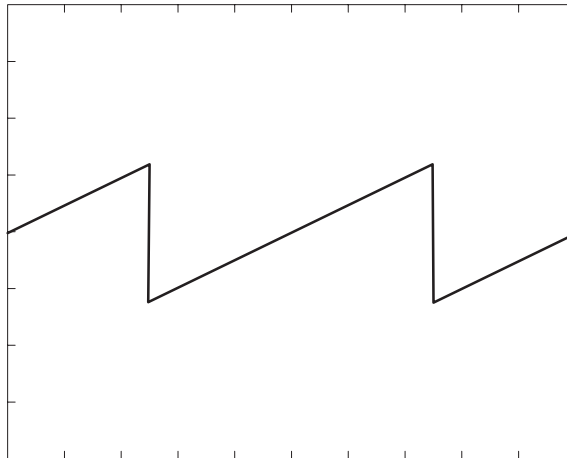

Figure 4–32: Waveform output when SW2 is closed

- c. Open the SW2 of the ground closure.
 - d. Verify that the oscilloscope displays the waveform shown in Figure 4–30.
7. Verify the EVENT IN connector pin 2 input by following the steps below:
 - a. Close SW3 of the ground closure to generate an event signal on the EVENT IN connector pin 2.
 - b. Verify that the oscilloscope displays the waveform shown in Figure 4–33.

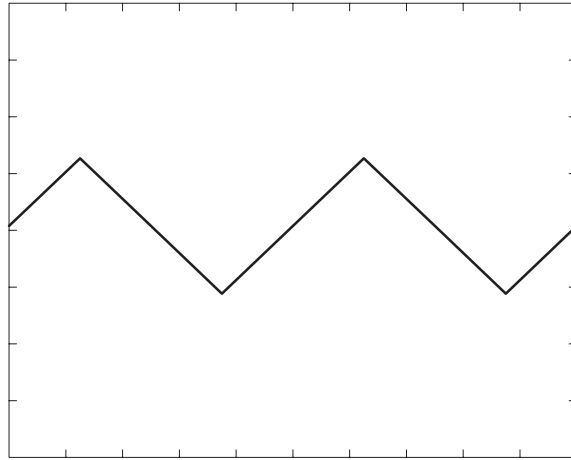

Figure 4-33: Waveform output when the SW3 is closed

- c. Open SW3 of the ground closure.
 - d. Verify that the oscilloscope displays the waveform in Figure 4-30.
 8. Verify the EVENT IN connector pin 3 input by doing the following substeps:
 - a. Close the SW4 of the ground closure to generate an event signal on the EVENT IN connector pin 3.
 - b. Verify that the oscilloscope displays the waveform shown in Figure 4-34.

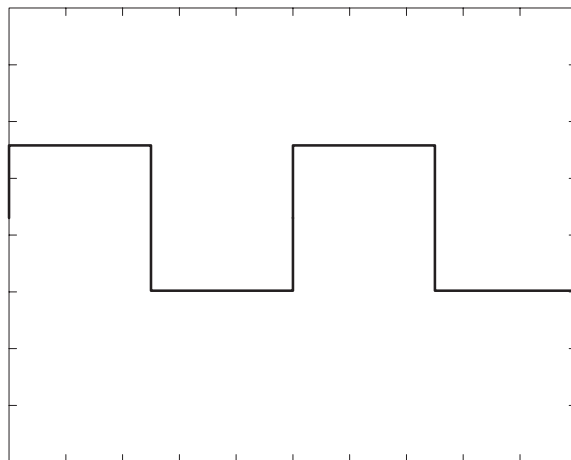

Figure 4-34: Waveform output when SW4 is closed

- c. Open SW4 of the ground closure.
 - d. Verify that the oscilloscope displays the waveform in Figure 4-30.

9. Retain the test hookup and control settings.

Check Strobe Input

1. Use the test hookup and oscilloscope settings from previous procedure.
2. Follow the substeps below to set the AWG400-Series controls and select the sequence file:
 - a. Push **UTILITY** (front-panel)→**System** (bottom)→**Factory Reset** (side)→**OK** (side).
 - b. Load the PT_STROB.SEQ file.

Refer to *Loading Files* on page 4–10 for file loading procedures.

- c. Push **SETUP** (front-panel)→**Run Mode** (bottom)→**Enhanced** (side) to set the run mode to enhanced.
3. Push the **RUN** and **CH1 OUT** buttons.

The LEDs above the RUN button and CH1 output connector are on.

- Verify that the $\overline{\text{CH1}}$ OUTPUT is off.
If the $\overline{\text{CH1}}$ LED is on, push **CH1 OUTPUT** (front-panel) to turn the LED off.
4. Verify the EVENT IN connector strobe pin input by doing the following substeps:
 - a. Verify that the waveform being displayed on the oscilloscope is shown in Figure 4–35.

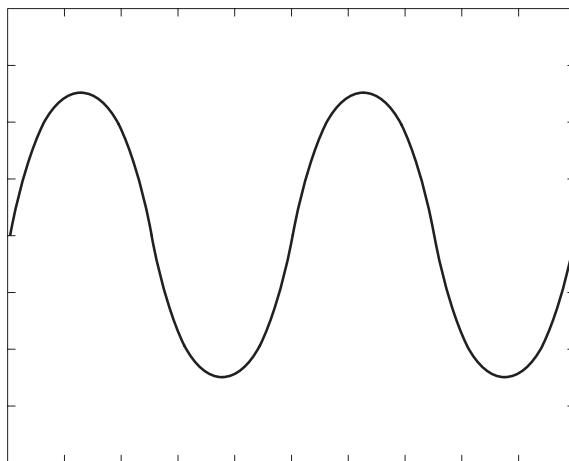

Figure 4-35: Initial waveform output

- b. Close SW5 of the ground closure to generate an event signal on the EVENT IN connector strobe pin.
- c. Verify that the oscilloscope displays the DC waveform as shown in Figure 4–36.

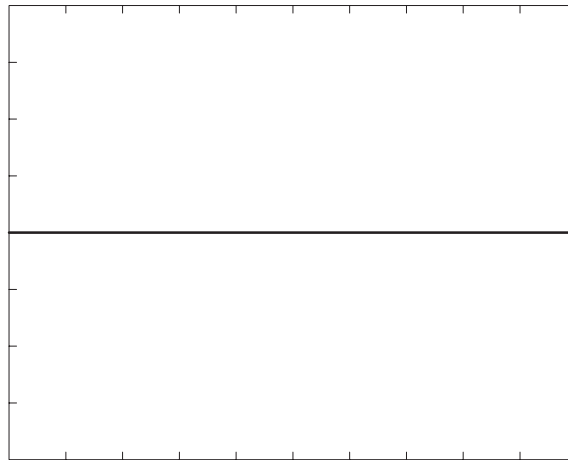

Figure 4–36: DC waveform output when the SW5 is closed

- d. Open SW5 of the ground closure.
 - e. Verify that the DC waveform is displayed on the oscilloscope.
 - f. Close SW5 of the ground closure again.
 - g. Verify that the oscilloscope displays the waveform as shown in Figure 4–35.
5. Push the **CH1 OUT** button to turn off the CH1 LED.
 6. Disconnect the oscilloscope and ground closure.

10 MHz Reference Input Tests

These procedures verify the 10 MHz reference input function of the AWG400-Series Arbitrary Waveform Generator.

| | |
|---------------------------|--|
| Equipment required | Two 50 Ω BNC coaxial cables, a frequency counter, and a function generator (AFG310). |
| Prerequisites | The AWG400-Series Arbitrary Waveform Generator must meet the prerequisites listed on page 4-8. |

1. Do the following steps to install the test hookup and set the test equipment controls:
 - a. Use a 50 Ω BNC coaxial cable to connect the AWG400-Series MASTER CLOCK OUT connector to the input A connector on the frequency counter.
 - b. Use a 50 Ω BNC coaxial cable to connect the AWG400-Series 10 MHz REF IN connector to the function generator output connector (see Figure 4-37).

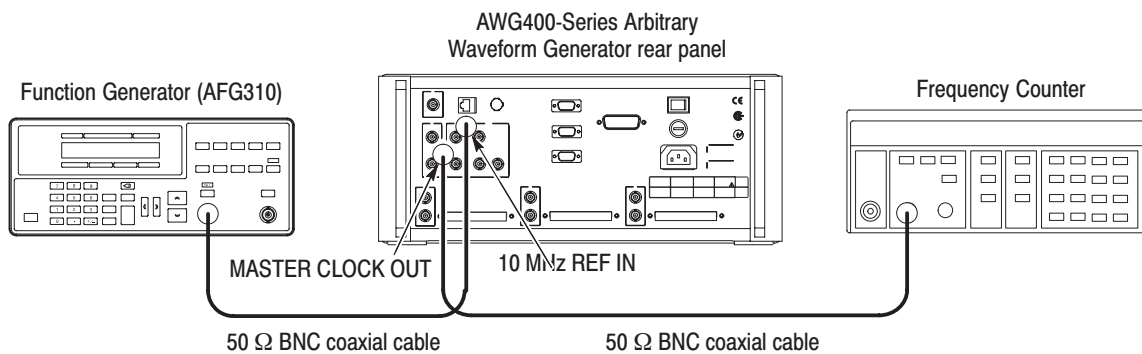

Figure 4-37: 10 MHz reference input initial test hookup

- c. Set the frequency counter controls as follows:

```

INPUT A
Coupling ..... AC
FUNCTION ..... A FREQ
Gate time ..... 0.2 s
Trigger Level ..... 0 V
    
```

- d. Set the function generator (AFG310) controls.

| | |
|------------------|---|
| Function | Square |
| Mode | Continuous |
| Parameters | |
| Frequency | 10 MHz (50 ppm accuracy) |
| Amplitude | 2.0 V into 50 Ω (4.0 V into 1 M Ω) |
| Offset | 0 V |
| Output | On |

2. Follow the substeps below to set up the AWG400-Series controls and load the waveform file:

- a. Reset the instrument.

Push **UTILITY** (front-panel)→**System** (bottom)→**Factory Reset** (side)→**OK** (side).

- b. Load the MODE.WFM file.

Refer to *Loading Files* on page 4–10 for file loading procedures.

- c. Set the reference clock to External.

■ Push **SETUP** (front-panel)→**Horizontal** (bottom)→**Clock Ref** (side)→**External**.

- d. Set the clock frequency.

■ Push **Clock** (side), then push **1**, **0**, **0**, and **M** (SHIFT+7) keys in this order or turn the general purpose knob to set the internal clock to 100 ms/s.

3. Verify that the frequency counter reading is 100 MHz \pm 5 kHz.

(This accuracy is dependent on the performance of the function generator.)

4. Modify the function generator (AFG310) controls as follows:

Frequency 10.1 MHz

5. Verify that the frequency counter reading is 101.0 MHz \pm 5.05 kHz.

6. Turn the function generator output off, and disconnect the function generator and frequency counter.

Master Clock Input Tests

These procedures verify the AWG400-Series Arbitrary Waveform Generator clock output signal level and frequency.

| | |
|---------------------------|--|
| Equipment required | Two 50 Ω BNC coaxial cables, a Function Generator, and an oscilloscope. |
| Prerequisites | The AWG400-Series Arbitrary Waveform Generator must meet the prerequisites listed on page 4–8. |

1. Do the following steps to install the test hookup and set the test equipment controls:
 - a. Use the 50 Ω BNC coaxial cable to connect the AWG400-Series CH1 output to the oscilloscope CH1 input connector.
 - b. Use a 50 Ω BNC coaxial cable to connect the AWG400-Series MASTER CLOCK IN connector to the function generator (AFG310) output connector (see Figure 4–38).

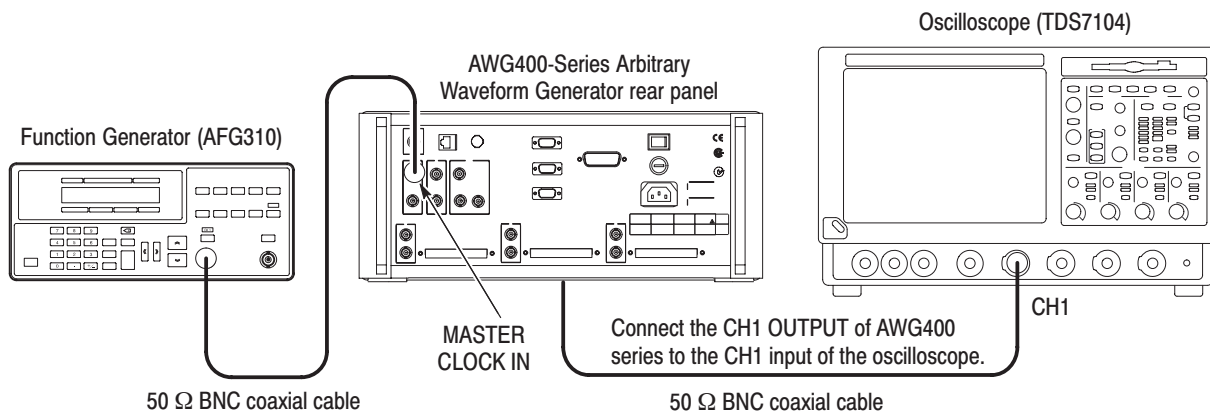

Figure 4–38: Master Clock input initial test hookup

- c. Set the oscilloscope controls as follows:

| | |
|---------------------|-------------|
| Vertical | CH1 |
| CH1 coupling | DC |
| CH1 scale | 0.2 V/div |
| CH1 input impedance | 50 Ω |
| Horizontal | |
| Sweep | 40 μ s |
| Trigger | |

| | |
|----------------|----------|
| Source | CH1 |
| Coupling | DC |
| Slope | Positive |
| Level | +100 mV |
| Mode | Auto |

- d. Set the function generator (AFG310) controls.

| | |
|-----------------|----------------------|
| Function | Square |
| Mode | Continuous |
| Parameters | |
| Frequency | 10 MHz |
| Amplitude | 0.7 V _{p-p} |
| Offset | 0.5 V |
| Output | On |

2. Follow the substeps below to set up the AWG400-Series controls and load the waveform file:

- a. Reset the instrument.

Push **UTILITY** (front-panel)→**System** (bottom)→**Factory Reset** (side)→**OK** (side).

- b. Load the MODE.WFM file.

Refer to *Loading Files* on page 4–10 for file loading procedures.

- c. Set the clock source to External.

■ Push **SETUP** (front-panel)→**Horizontal** (bottom)→**Clock Src** (side)→**External**.

3. Set CH1 output to enable.

Push the **RUN** (front-panel) and **CH1 OUTPUT** (front-panel).

The LEDs above the RUN button and CH1 OUTPUT are on.

Verify that the AWG output is running.

4. Verify that the output signal period is 100 μ s.
5. Push **CH1 OUTPUT** (front-panel) to turn off the CH1 LED.
6. Push **RUN** (front-panel) to turn off the RUN LED.
7. Turn the function generator output off and disconnect the function generator and oscilloscope.

ADD Input Tests

These procedures verify the AWG400-Series Arbitrary Waveform Generator ADD input function.

NOTE. Verify the CH1 output for the AWG410, CH1 and CH2 outputs for AWG420, and CH1, CH2 and CH3 outputs for AWG430.

| | |
|---------------------------|---|
| Equipment required | Two 50 Ω BNC coaxial cable, a BNC-to-banana adapter, a 50 Ω precision terminator, a function generator, and a digital multimeter (DMM). |
| Prerequisites | The AWG400-Series Arbitrary Waveform Generator must meet the prerequisites listed on page 4-8. |

1. Do the following steps to install the test hookup and set the test equipment controls:
 - a. Use a 50 Ω BNC coaxial cable to connect to the rear panel of the AWG400-Series ADD IN CH1 input connector to the function generator (AFG310) output connector (see Figure 4-39).
 - b. Connect the BNC-to-banana adapter and a 50 Ω BNC coaxial cable to the digital multimeter input connector. Connect the loose end of the 50 Ω BNC coaxial cable to the AWG400-Series CH1 output connector (see Figure 4-39).

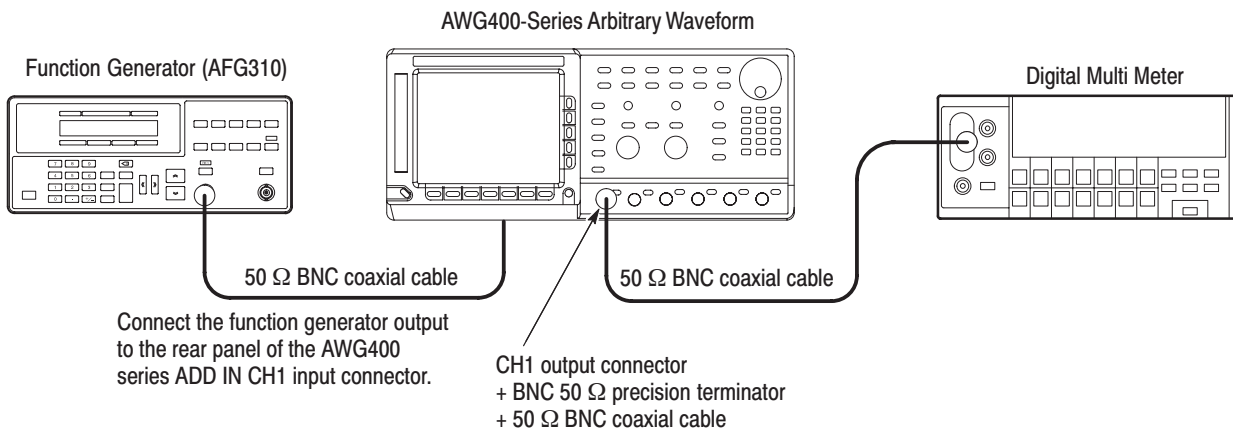

Figure 4-39: ADD IN input initial test hookup

- c. Set the DMM controls as follows:

| | |
|-------------|-------|
| Mode | VDC |
| Range | Auto |
| Input | Front |

- d. Set the function generator (AFG310) controls.

| | |
|----------------|------------|
| Function | DC |
| Mode | Continuous |
| Parameters | |
| Offset | 1.0 V |
| Output | Off |

2. Set up the AWG400-Series, and load the waveform file.

- a. Push **UTILITY** (front-panel)→**System** (bottom)→**Factory Reset** (side)→**OK** (side).
- b. Select the channel.
Push the desired channel button **CHx** (left side of the front panel) that you want to verify.
- c. Set the output amplitude.
 - Push **SETUP** (front-panel)→**Vertical** (bottom)→**Amplitude** (side).
 - Push **0**, **.**, **0**, **2**, and **ENTER** keys in this order or turn the general purpose knob to set the amplitude to 0.02 V.
- d. Add signal to external.
 - Push **Add...** (side)→**External** (side).
- e. Load the DC0.WFM file.

Refer to *Loading Files* on page 4–10 for file loading procedures.

3. Push the **RUN** (front-panel) and **CH1 OUTPUT** (front-panel) buttons.

The LEDs above the RUN button and CH1 output connector are on.

- Verify that $\overline{\text{CH1}}$ output is off.
If the $\overline{\text{CH1}}$ output is on, push **CH1 OUTPUT** button to turn it off.

4. Verify the output level relative to the input level.

- a. Verify the level when the function generator output is off.
 - Verify the DMM readout. Verify that the DMM reads out a level from -10 mV to $+10$ mV and note the value.

Marker Output Tests

These procedures verify the accuracy of the AWG400-Series Arbitrary Waveform Generator marker output level.

NOTE. You need to verify CH1 output for AWG410, the CH1 and CH2 outputs for AWG420, and the CH1, CH2, and CH3 outputs for AWG430.

| | |
|---------------------------|--|
| Equipment required | A 50 Ω BNC coaxial cable and an oscilloscope. |
| Prerequisites | The AWG400-Series Arbitrary Waveform Generator must meet the prerequisites listed on page 4-8. |

1. Do the following steps to install the test hookup and set the test equipment controls.
 - a. Use a BNC coaxial cable to connect the AWG400-Series CH1 MARKER OUT 1 connector to the oscilloscope CH1 input connector (see Figure 4-40).

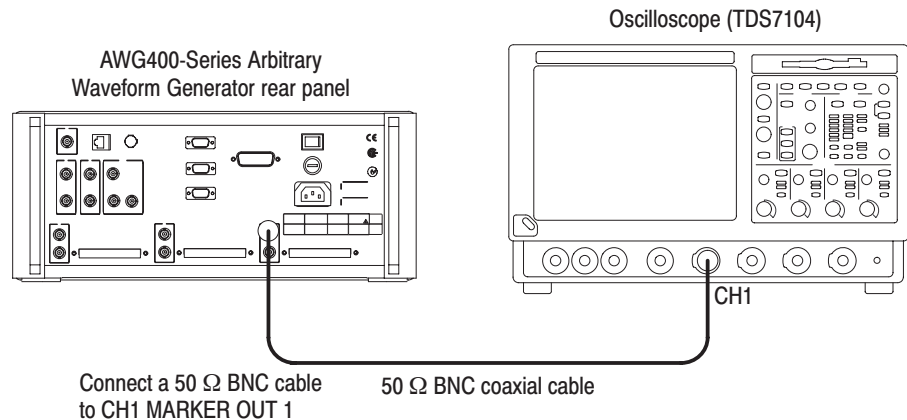

Figure 4-40: Marker output initial test hookup

- b. Set the oscilloscope controls as follows:

| | |
|---------------------|-------------|
| Vertical | CH1 |
| CH1 coupling | DC |
| CH1 scale | 1 V/div |
| CH1 input impedance | 50 Ω |
| CH1 offset | 0 V |
| Horizontal | |

| | |
|----------------|---------------|
| Sweep | 1 μ s/div |
| Trigger | |
| Source | CH1 |
| Coupling | AC |
| Slope | Positive |
| Level | 0 V |
| Mode | Auto |

2. Follow the substeps below to set up the AWG400-Series controls and load the waveform file:

- a. Push **UTILITY** (front-panel)→**System** (bottom)→**Factory Reset** (side)→**OK** (side).
- b. Load the MODE.WFM file for CH1.

Refer to *Loading Files* on page 4–10 for file loading procedures.

c. Load the MODE.WFM file for CH2 (the AWG420 and AWG430 need this setup).

- Push the **CH2** button (left side of front panel).
- Load the MODE.WFM file.

Refer to *Loading Files* on page 4–10 for file loading procedures.

d. Load the MODE.WFM file for CH3 (the AWG430 needs this setup).

- Push the **CH3** button (left side of front panel).
- Load the MODE.WFM file.

Refer to *Loading Files* on page 4–10 for file loading procedures.

3. Push the **RUN** button.

The LED above the RUN button is on.

NOTE. Always perform the marker level measurements after the level has stabilized. The marker level measurements do not include the overshoot or undershoot.

4. Follow the substeps below to verify the marker output level:

- a. Verify the Marker 1 output level. Verify that the waveform is displayed as shown in Figure 4–41.
 - Verify the low level of the Marker 1 output. Verify that the low level on the oscilloscope screen reads from 0.0 V to 0.1 V.
 - Verify the high level of the Marker 1 output. Verify that the high level on the oscilloscope screen reads from 2.4 V to 2.5 V.

- b. Modify the hookup for Marker 2.
 - Disconnect the cable from the CH1 MARKER OUT 1 connector.
 - Connect the cable to the CH1 MARKER OUT 2 connector.
- c. Verify the Marker 2 output level.
 - Verify the low level of the Marker 2 output. Verify that the low level on the oscilloscope screen reads from 0.0 V to 0.1 V.
 - Verify the high level of the Marker 2 output. Verify that the high level on the oscilloscope screen reads from 2.4 V to 2.5 V.

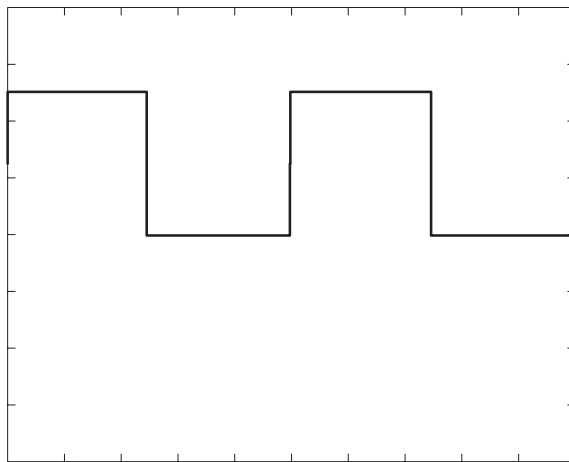

Figure 4-41: Marker output waveform

5. Modify the hookup for CH2.
 - a. Push the **RUN** button (front-panel). The RUN LED is off.
 - b. Disconnect the cable from the CH1 MARKER OUT 2 connector.
 - c. Connect the cable to the CH2 MARKER OUT 1 connector.
6. Do steps 2 through 5 for the CH2 and CH3 markers.
7. Push the **RUN** button (front-panel). The RUN LED is off. Disconnect the hookup.

Channel Skew Tests (AWG420 and AWG430 only)

These procedures verify the channel skew function of the AWG400-Series.

| | |
|---------------------------|--|
| Equipment required | Two 50 Ω BNC coaxial cables and an oscilloscope. |
| Prerequisites | The AWG400-Series Arbitrary Waveform Generator must meet the prerequisites listed on page 4–8. |

1. Do the following steps to install the test hookup and set the test equipment controls:
 - a. Use the 50 Ω BNC coaxial cables to connect the AWG400-Series CH1 and CH2 outputs to the oscilloscope CH1 and CH2 input connectors (see Figure 4–42).

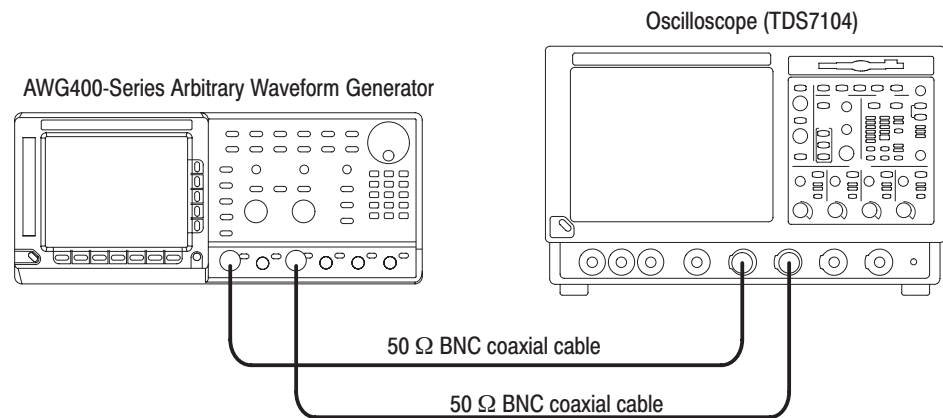

Figure 4-42: Channel skew test hookup

- b. Set the oscilloscope controls as follows:

| | |
|-----------------------------|-------------|
| Vertical | CH1 and CH2 |
| CH1 and CH2 coupling | DC |
| CH1 and CH2 scale | 0.2 V/div |
| CH1 and CH2 input impedance | 50 Ω |
| CH1 and CH2 offset | 0 V |
| Horizontal | |
| Sweep | 1 ns/div |

| | |
|----------------|----------|
| Trigger | |
| Source | CH1 |
| Coupling | AC |
| Slope | Positive |
| Level | 0 V |
| Mode | Auto |

2. Follow the substeps below to set up the AWG400-Series controls and load the waveform file:

- a. Push **UTILITY** (front-panel)→**System** (bottom)→**Factory Reset** (side)→**OK** (side).

- b. Load the PULSE.WFM file for CH1, CH2, and CH3.

Refer to *Loading Files* on page 4–10 for file loading procedures.

3. Output the AWG400-Series CH1 and CH2.

- Push the **RUN**, **CH1 OUTPUT**, and **CH2 OUTPUT** front-panel buttons. The RUN, CH1, and CH2 LEDs are on.

- Verify that the $\overline{\text{CH1}}$ and $\overline{\text{CH2}}$ outputs are off. Verify that the $\overline{\text{CH1}}$ and $\overline{\text{CH2}}$ LEDs are off.

If $\overline{\text{CH1}}$ LED is on, push the **$\overline{\text{CH1}}$ OUTPUT** (front-panel) button to turn it off.

If $\overline{\text{CH2}}$ LED is on, push the **$\overline{\text{CH2}}$ OUTPUT** (front-panel) button to turn it off.

4. Verify CH1 and CH2 skew.

- a. Push **SETUP** (front panel) → **Horizontal** (bottom) → **Skew** (side) → **Reset** (side).

- b. **For the AWG430 Only.** Use the **▼** and **▲** buttons to select the channel that you want to verify.

- c. Verify that the CH2 output skew is 0 ± 100 ps relative to CH1 on the oscilloscope screen.

- d. Using the general purpose knob, change the CH2 skew from -2.52 ns to $+2.52$ ns continuously.

- e. Verify that the CH2 output delay changes from about -2.52 ns to $+2.52$ ns relative to CH1 on the oscilloscope screen.

5. Modify the hookup for verifying the CH1 through CH3 skew.
 - a. Push the **RUN**, **CH1 OUTPUT**, and **CH2 OUTPUT** front panel buttons. The RUN, CH1, and CH2 LEDs are off.
 - b. Disconnect the BNC cable at the AWG400-Series CH2 output connector.
 - c. Connect the BNC cable to the CH3 connector.
6. Repeat step 3 to step 5 for CH1 through CH3.
7. Disconnect the hookup.
 - a. Push the **RUN** (front-panel) button. The RUN LED is off.
 - b. Disconnect the BNC cables from the oscilloscope.

Master Clock Output Tests

These procedures verify the AWG400-Series clock output signal level and frequency.

| | |
|---------------------------|---|
| Equipment required | A 50 Ω BNC coaxial cable and an oscilloscope. |
| Prerequisites | The AWG400 Arbitrary Waveform Generator must meet the prerequisites listed on page 4-8. |

1. Do the following steps to install the test hookup and set the test equipment controls:
 - a. Use the 50 Ω BNC coaxial cable to connect the AWG400-Series MASTER CLOCK OUT output to the oscilloscope input connector (see Figure 4-43).

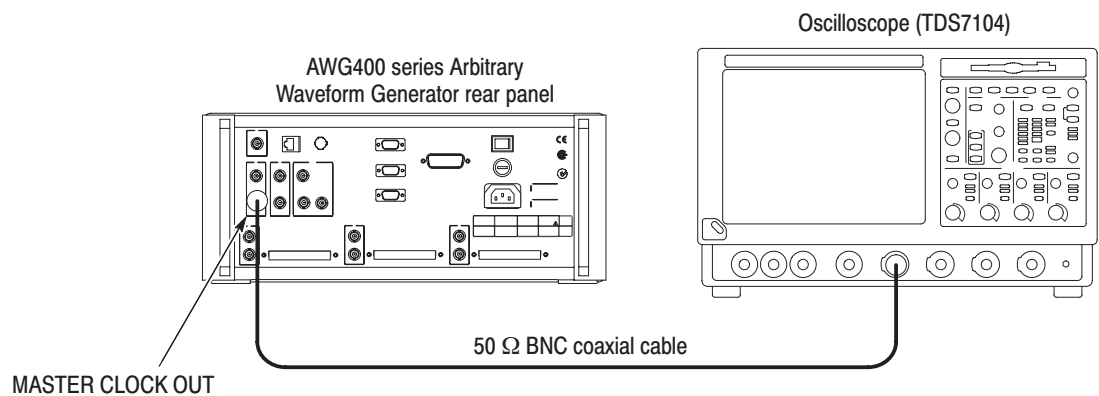

Figure 4-43: Master Clock output initial test hookup

- b. Set the oscilloscope controls as follows:

| | |
|---------------------|-------------|
| Vertical | CH1 |
| CH1 coupling | DC |
| CH1 scale | 0.5 V/div |
| CH1 offset | 0 V |
| CH1 input impedance | 50 Ω |
| Horizontal | |
| Sweep | 5 ns/div |
| Trigger | |
| Source | CH1 |
| Coupling | AC |
| Slope | Positive |

Level 0 V
Mode Auto

2. Follow the substeps below to set up the AWG400-Series controls and load the waveform file:

a. Push **UTILITY** (front-panel)→**System** (bottom)→**Factory Reset** (side)→**OK** (side).

b. Load the MODE.WFM file.

Refer to *Loading Files* on page 4–10 for file loading procedures.

c. Push **SETUP** (front-panel)→**Horizontal** (bottom)→**Clock** (side).

d. Push **1, 0, 0** and **M** (SHIFT+7) keys in this order or turn the general purpose knob to set the internal clock frequency to 100 MHz.

3. Verify that the clock signal amplitude is $1\text{ V} \pm 0.3\text{ V}$, and the clock signal period is about 10 ns ($100\text{ MHz} \pm 20\text{ kHz}$).

4. Disconnect the cable from the MASTER CLOCK OUT connector.

10 MHz Reference Output Tests

These procedures verify the AWG400-Series 10 MHz Reference Output level and frequency.

| | |
|---------------------------|--|
| Equipment required | A 50 Ω BNC coaxial cable and an oscilloscope. |
| Prerequisites | The instrument must meet the prerequisites listed on page 4–8. |

1. Do the following steps to install the test hookup and set the test equipment controls:
 - a. Use the 50 Ω BNC coaxial cable to connect the AWG400-Series Arbitrary Waveform Generator 10 MHz REF OUT output to the oscilloscope input connector (see Figure 4–44).

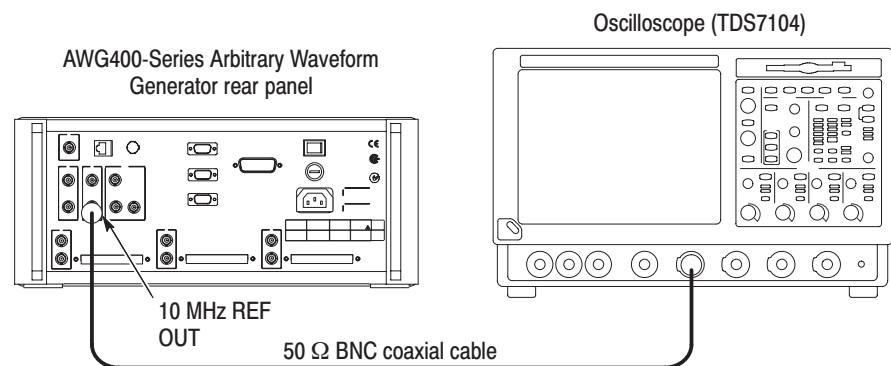

Figure 4–44: 10MHz Reference output initial test hookup

- b. Set the oscilloscope controls as follows:

| | |
|---------------------|-------------|
| Vertical | CH1 |
| CH1 coupling | DC |
| CH1 scale | 0.5 V/div |
| CH1 offset | 0 V |
| CH1 input impedance | 50 Ω |
| Horizontal | |
| Sweep | 25 ns/div |
| Trigger | |
| Source | CH1 |
| Coupling | AC |
| Slope | Positive |
| Level | 0 V |
| Mode | Auto |

2. Follow the substeps below to set up the AWG400-Series Arbitrary Waveform Generator controls and load the waveform file:
 - a. Push **SETUP** (front-panel)→**System** (bottom)→**Factory Reset** (side)→**OK** (side).
 - b. Load the MODE.WFM file.

Refer to *Loading Files* on page 4–10 for file loading procedures.

- c. Push **SETUP** (front panel)→**Horizontal** (bottom)→**Clock** (side).
 - d. Push **1, 0, 0,** and **M** (SHIFT+7) keys in this order or used the general purpose knob to set the internal clock frequency to 100 MHz.
3. Verify that the 10 MHz REF OUT clock signal amplitude is equal to or greater than 1.0 V and the clock signal period is about 100 ns.
4. Disconnect the BNC cable from the oscilloscope.

Digital Data Output Tests (Option 03 Only)

These procedures verify the AWG400-Series digital data output level accuracy and skew.

NOTE. Verify that the CH1 output for AWG410, the CH1 and CH2 outputs for AWG420, and the CH1, CH2, and CH3 outputs for AWG430.

Check Output Levels

| | |
|---------------------------|---|
| Equipment required | A P4116 CMOS output pod, a pin-header SMB cable Tektronix part number (012-1503-00), a SMB-BNC adapter Tektronix part number (015-0671-00). |
| Prerequisites | The instrument must meet the prerequisites listed on page 4-8. |

1. Install the test hookup and set the test equipment controls.
 - a. Connect CH1 DIGITAL DATA OUT through the flat cable to P4116. See Figure 4-45.
 - b. Connect CH1 DIGITAL DATA OUT. The CLOCK pin (Pin 1) goes through the pin-header SMB cable to the oscilloscope CH1. See Figure 4-46 and Table 4-4.
 - c. Connect CH1 DIGITAL DATA OUT. The D0 pin (Pin 33) goes through the pin-header SMB cable to the oscilloscope CH2.

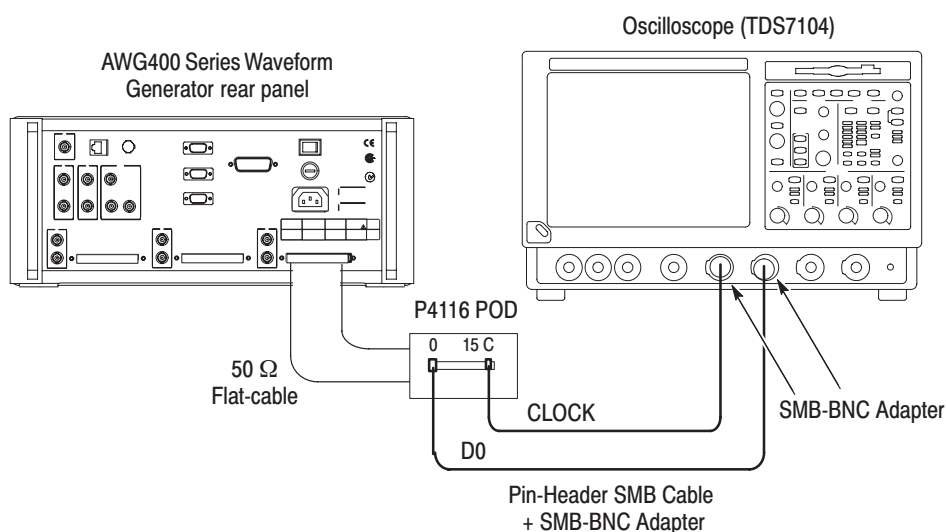

Figure 4-45: Digital data output level initial test hookup

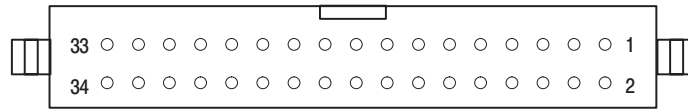

Figure 4-46: P4116 Output Connector

Table 4-4: P4116 Output Connector Pin Assignment

| Pin No. | Signal | Pin No. | Signal |
|---------|-----------|---------|--------|
| 1 | CLOCK | 2 | GND |
| 3 | D15 (MSB) | 4 | GND |
| 5 | D14 | 6 | GND |
| 7 | D13 | 8 | GND |
| 9 | D12 | 10 | GND |
| 11 | D11 | 12 | GND |
| 13 | D10 | 14 | GND |
| 15 | D9 | 16 | GND |
| 17 | D8 | 18 | GND |
| 19 | D7 | 20 | GND |
| 21 | D6 | 22 | GND |
| 23 | D5 | 24 | GND |
| 25 | D4 | 26 | GND |
| 27 | D3 | 28 | GND |
| 29 | D2 | 30 | GND |
| 31 | D1 | 32 | GND |
| 33 | D0 (LSB) | 34 | GND |

d. Set the oscilloscope controls.

- Vertical CH1 and CH2
 - Coupling DC
 - Scale 1 V/div
 - Offset 0 V
 - Input impedance 50 Ω
- Horizontal
 - Sweep 10 μs/div
- Trigger
 - Source CH2
 - Coupling AC

| | |
|-------------|----------|
| Slope | Positive |
| Level | 0 V |
| Mode | Auto |

2. Set up the AWG400-Series, controls and load the waveform file.
 - a. Initialize the AWG400-Series controls.
Push **UTILITY** (front-panel)→
System (bottom)→**Factory Reset** (side)→**OK** (side).
 - b. Select the channel.
 - Push one of the buttons (**CHx**) for the channel that you have selected.
 - Push the **DIGITAL** (front-panel) button.
 - c. Load the waveform file.
 - Load the DOUT.PAT file. Refer to *Loading Files* on page 4–88 for file loading procedures.
 - d. Set the clock frequency.
 - Push **SETUP** (front-panel)→
Horizontal (bottom) → **Clock** (side).
 - Push **1**, **0**, and **M** (SHIFT+7) in this order or turn the general purpose knob to set the frequency to 10 MHz.
 - e. Turn on the digital data out. Push the **Vertical** (bottom)→**Output** (side) button so that the Output is set to On.
3. Turn on the AWG400-Series output. Push the **RUN** button so that the LED above the RUN button lights.

NOTE. When taking output level measurements with an oscilloscope, the high and low level voltages contain ringing (overshoot or undershoot). Always perform the measurements after the level has stabilized.

4. Verify the digital data output level accuracy (see Figure 4–47).
 - a. Verify the D0 output level.
 - Verify the low level. Verify that the reading for the low level on the oscilloscope screen is from 0.0 V to 0.1 V.
 - Verify the high level. Verify that the reading for the high level on the oscilloscope screen is from 2.3 V to 2.5 V.

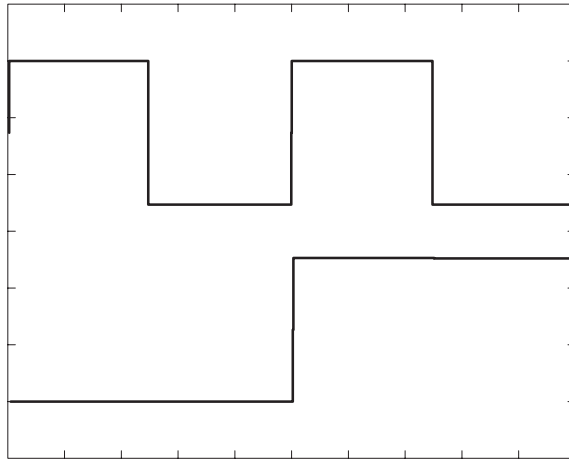

Figure 4-47: Clock output and data output

5. Modify the hookup for verifying D1.
 - a. Push the **RUN** button (front-panel). The RUN LED is off.
 - b. Disconnect the pin-header SMB cable at DIGITAL DATA OUT: D0.
 - c. Connect the pin-header SMB cable at DIGITAL DATA OUT: D1.
6. Verify D1 to D15 and CLOCK. Repeat step 3 through step 5 for verifying the level and waveform on D1 to D15 and CLOCK output.
7. Modify the hookup for verifying CH2.
 - a. Push the **Output** (side) button and turn off the digital data output.
 - b. Disconnect the flat cable at CH1 DIGITAL DATA OUT.
 - c. Connect the flat cable to the other channel DIGITAL DATA OUT that you will verify.
 - d. Disconnect the pin-header SMB cable at DIGITAL DATA OUT: D15.
 - e. Connect the pin-header SMB cable at DIGITAL DATA OUT: D0.
8. Repeat step 2 through step 7 to verify the level and waveform on CH2 and CH3 digital output.
9. Push the **Output** (side) button, and turn off the digital data output.
10. Push the **CH OFF** to turn off all channels.
11. Push the **RUN** (front) button. The RUN LED is off.
12. Remove the cables.

Adjustment Procedures

This section contains the information needed to manually adjust the AWG400-Series Arbitrary Waveform Generator.

Overview

Description This section is divided into the following subsections:

- *Overview*. Provides basic information about adjustment requirements
- *Before Adjustments*. Provides general information about adjusting the waveform generator and about the Performance Check/Adjustment disk files.
- *Adjustment Instructions*. Provides procedures for manually adjusting the waveform generator.

Purpose Use the *Adjustment Instructions* subsection to return the waveform generator to conformance with the performance specified in the *Specifications* section. This procedure is not required to verify the performance of the waveform generator. To verify the performance of the instrument, refer to the *Performance Verification* section.

Adjustment Interval Generally, these adjustments should be done every 12 months.

Adjustment After Repair After the removal and replacement of a module due to electrical failure, do the adjustment procedures listed in Table 5–1. Which adjustments are required depends on the module or modules that you replace.

Table 5–1: Adjustments required

| Removed and replaced module | Adjustments required |
|--|--|
| A72 Output board (STD) | Calibration refer to page 4–4 |
| A70 Output board (Op-05) | Calibration refer to page 4–4 |
| A52 AWG board (AWG410) | Calibration Reference Clock frequency |
| A52 AWG board (AWG420/430) | Reference Clock frequency Skew |
| A50 SEQUENCE board and Flash Disk (AWG420/430) | Calibration and Skew |

Table 5-1: Adjustments required (Cont.)

| Removed and replaced module | Adjustments required |
|-----------------------------|--------------------------------|
| Power Module | Low-Voltage Power Supply level |
| Other modules | None |

Adjustments There are three adjustment procedures, as listed in Table 5-2. You can do Calibration and Marker level adjustment without removing the cabinet.

Table 5-2: Adjustments

| Adjustments | Refer to |
|----------------------------|-----------|
| Calibration | Page 4-4 |
| 10 MHz Ref Clock frequency | Page 5-9 |
| DAC output signal | Page 5-11 |
| Skew | Page 5-14 |

Before doing the adjustments, note the following requirements.

Personnel This procedure is only to be performed by trained service technicians.

Warm-Up Period This waveform generator requires a 20 minute warm-up time in a 20° C to 30° C environment before it is adjusted. Adjustments done before the operating temperature has stabilized may cause errors in performance.

Access An additional cooling fan must be provided if you need to remove the cabinet when making the adjustments in this procedure. Refer to *Before Adjustments* on the next page for detailed information.

Self Calibration Calibrate the waveform generator using the self calibration routine. Refer to the *Performance Verification* section for instructions.

Performance Check/Adjustments Files These adjustment procedures require you to load a file from the Performance Check/Adjustment disk supplied with the waveform generator. Refer to *Adjustment Instructions* in this subsection for information about this file.

Test Equipment Table 2-2 lists all test equipment required to adjust the waveform generator.

Equipment Required Table 2–2 lists the test equipment required to adjust the waveform generator.

Table 5–3: Test equipment

| Item description | Minimum requirements | Example | Purpose |
|---------------------------|--|--------------------------------------|--------------------------------|
| 1. Oscilloscope | Bandwidth > 500 MHz | Tektronix part number TDS7104 | Output signal adjustments |
| 2. Oscilloscope | Bandwidth > 6 GHz Rise time > 58.3 ps | Tektronix part number TDS820 | Output signal adjustments |
| 3. Frequency counter | 1 MHz to 10 MHz Accuracy < 0.2 ppm | Anritsu MF1603A | Output signal adjustment |
| 4. Digital multimeter | DC volts range: 0.05 V to 10 V, Accuracy: $\pm 0.1\%$ | Fluke 8842A | Check voltage |
| 5. BNC cable | Impedance 50 Ω | Tektronix part number 012-0482-00 | Signal interconnection |
| 6. Adapter | BNC (Female) to SMA (Male), 50 Ω | Tektronix part number 015-1018-00 | Signal interconnection |
| 7. Attenuator | SMA X5 attenuator | | Signal interconnection |
| 8. Adjustment Tool | Less than 1/8 inch diameter and over 4 inches long | | Enabling service mode |
| 9. Performance check disk | Must use example listed | Tektronix part number 062-A259-xx | Used to provide waveform files |
| 10. Fan | | | Cooling the waveform generator |

Before Adjustments

Use the following instructions to prepare the waveform generator for adjustment, load the adjustment file required for these procedures, and make adjustments.

Providing Access

Before doing the Reference Clock adjustment, remove the waveform generator rear cover and cabinet. See the *Maintenance* section for instructions on removing the cabinet and replacing it after adjustment is done.



CAUTION. To avoid damaging the eject button, remove the floppy disk (if present) from the floppy disk drive before removing the cabinet.

Cooling With the rear cover and cabinet removed, the waveform generator assembly does not cool properly while power is applied. A separate fan is needed to prevent heat build-up. Place the fan so it blows air to the A50 AWG board, as shown in Figure 5-1.



CAUTION. To prevent damage to the waveform generator due to over heating, do not do the adjustment procedures without providing additional cooling, as shown below.

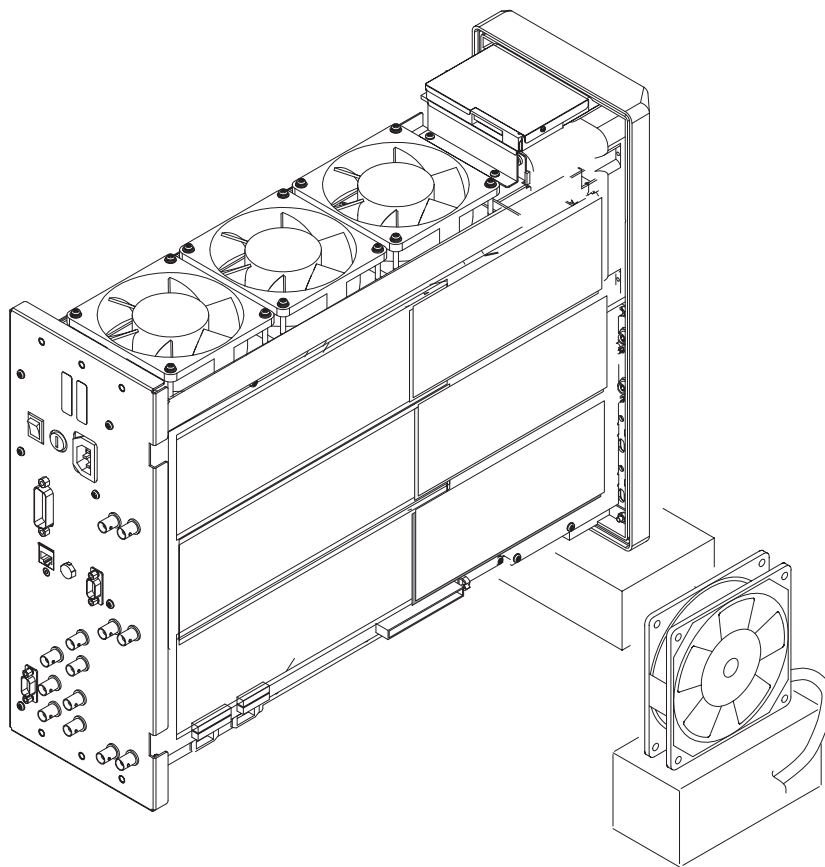

Figure 5-1: Cooling the waveform generator during adjustment procedures

Enabling Service Mode

The Skew adjustment procedure uses the Service menu that is a submenu of the Utility menu. To enter this menu, you must do the following step to enable service mode using the switch on the A11 Connector board:

Power on the waveform generator by pushing **ON/STB** button while pressing the service switch on the A10 Connector board. See Figure 5-2.

If you perform the adjustment procedure without removing the cabinet, you must insert the adjustment tool (Item 8 in Table 2-2) in the hole on the left side of the waveform generator to engage the service switch.

Powering off the waveform generator disables the service mode.

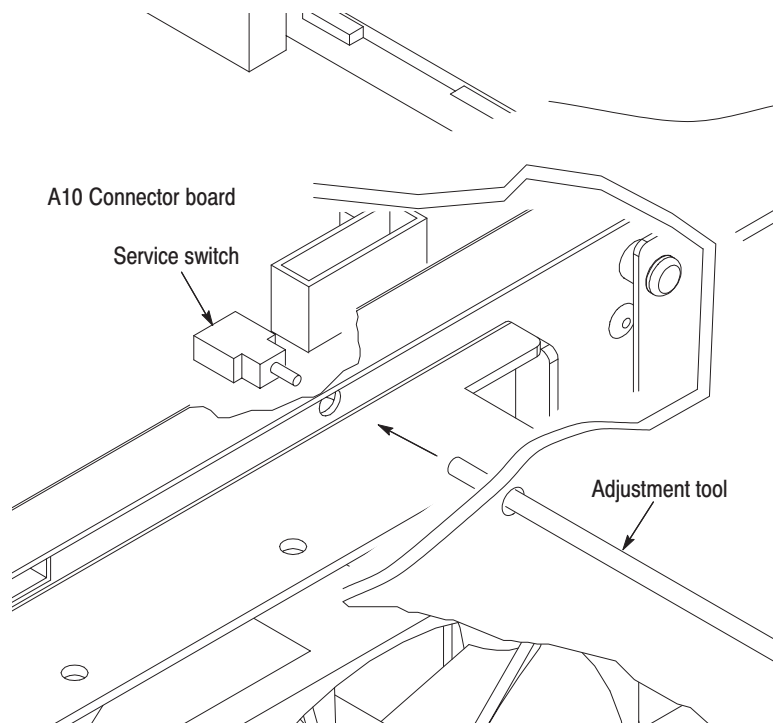

Figure 5-2: Accessing the service switch

**Performance
Check/Adjustment Files**

Table 5–4 lists the waveform files provided on the Performance Check/Adjustment disk, which is required to do the adjustments.

For instructions on loading files, see *Operating Basics: Loading Files* and the *Reference: Waveform Sequence Menu* section of the user manual. After loading the files, press the floppy disk drive eject button, and remove the floppy disk.

Table 5–4: File list for Performance Check/Adjustment disk

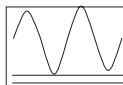
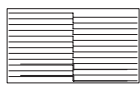
| No. | File name | Wfm shape | Wfm Point | Clock | Usage |
|-----|------------|---|-----------|----------|-----------------------|
| 1 | S130X2.WFM |  | 260 | 100 MS/s | DAC output adjustment |
| 2 | DOUT.PAT |  | 512 | 100 MS/s | Skew adjustment |

Adjustment Instructions

Low-Voltage Power Supply

This procedure adjusts the level of the low-voltage power supply. Before doing the adjustment, remove the A70/A72 Output board.

NOTE. Do this procedure only when replacing the low-voltage power supply unit.

| Equipment Required | |
|--------------------|--|
|--------------------|--|

| | |
|--|-------------------------------|
| | A digital multimeter (Item 4) |
|--|-------------------------------|

1. *Adjust the voltage level:* Adjust -5 V pod on the power supply unit so that TP0205 (VEE) on the A50 Sequence board is -5.30 V \pm 0.02 V. See Figure 5-3.
2. Verify that the voltage of TP104 is between -5.30 V and -5.20 V.

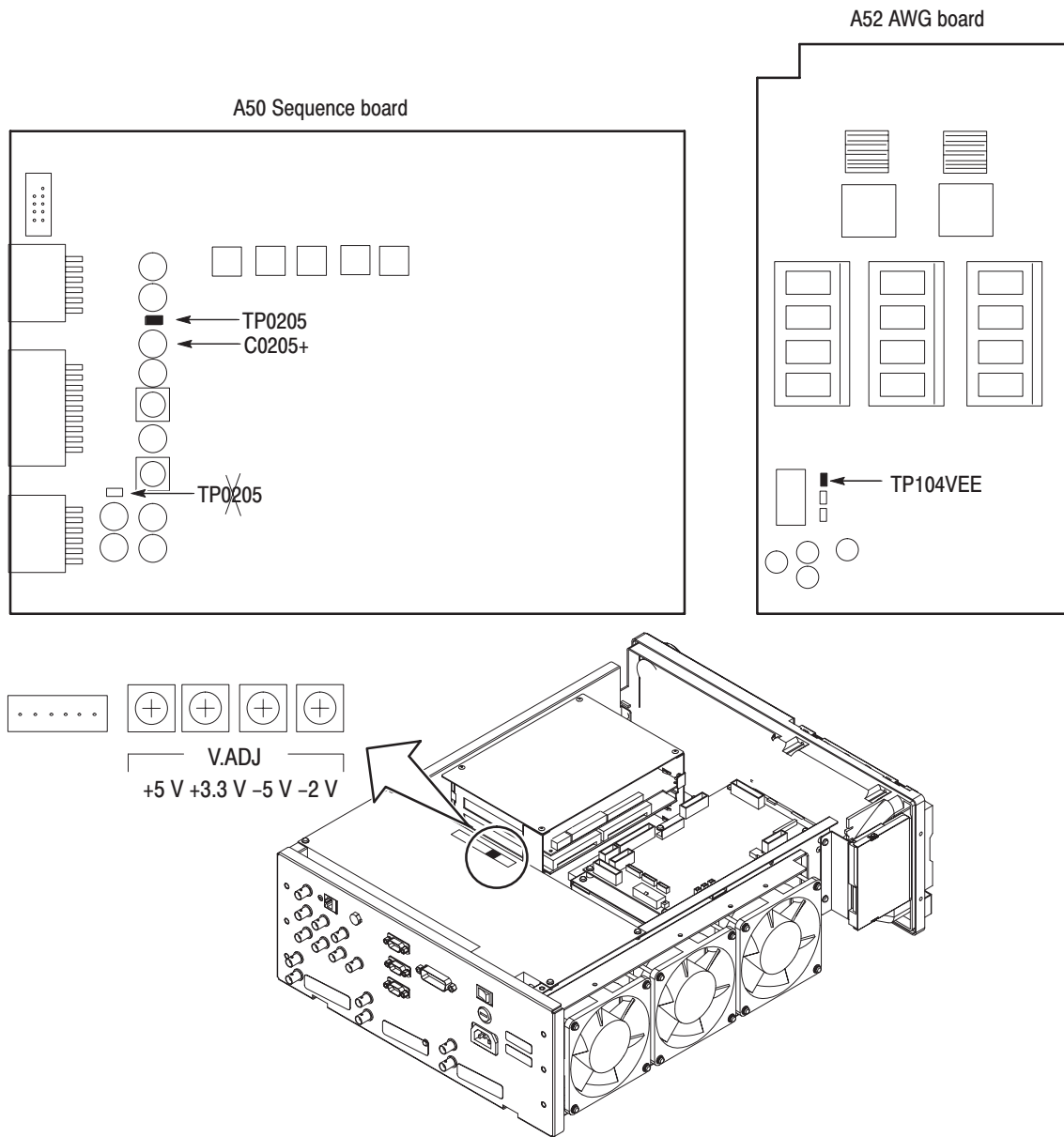

Figure 5-3: Adjustment location for the power supply unit

Adjustment for Reference Clock Frequency

This procedure adjusts the clock reference calibration data.

| | |
|---------------------------|---|
| Equipment Required | A frequency counter (Item 3) A 50 Ω BNC coaxial cable (Item 5). |
| Prerequisites | The AWG400-Series Arbitrary Waveform Generator must be started up with service mode (refer to Enabling Service Mode on page 5-5). |

NOTE. In this adjustment, the AWG400-Series is started in service mode. Refer to Enabling Service Mode on page 5-5.

1. Do the following steps to install the test hookup and set the test equipment controls:
 - a. Connect the frequency counter to the AWG.

Use a 50 Ω BNC coaxial cable to connect the MASTER CLOCK OUT of the AWG400-Series rear panel to CH1 input connector on the frequency counter. (see Figure 5-4).

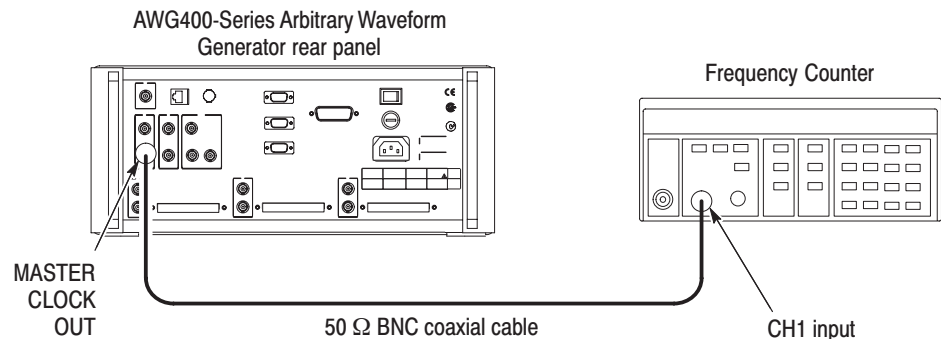

Figure 5-4: Hookup for the reference clock frequency adjustment

- b. Set the frequency counter controls as follows:

| | |
|---------------------|------------|
| INPUT A | |
| Slope | \uparrow |
| Coupling | AC |
| FUNCTION | A FREQ |
| Gate time | 0.2 s |
| Trigger Level | 0 V |

2. Set up the AWG400-Series, and load the waveform file:
 - a. Reset the AWG400-Series:
Push **UTILITY** (front-panel)→**System** (bottom)→**Factory Reset** (side)→**OK** (side).
 - b. Push **Horizontal** (bottom)→ **Clock Src** (side)→ **Internal** (side).
Push **Clock Ref** (side)→ **Internal** (side).
 - c. Select clock frequency:
Push **Clock** (side) → **2, 0, 0** and **M** (SHIFT+7) keys in this order,
or turn the general purpose knob to set the internal clock frequency to 200 MS/s.
3. Push **UTILITY** (front-panel)→ **Service** (bottom) → **Tweak Awg4** (pop-up).
 - a. AWG displays “Can’t find clock reference adjust file. You must save adjust data with SAVE button.” Push **OK** (side) button.
4. Push **Clock Ref. DAC** (side) button.
5. Adjust the general purpose knob so that the frequency counter reading is the closest to 200 MHz.
6. Push **Save Clock Ref. Adjust** (side) button to save the clock reference adjust file.
7. Verify that the DAC value on the AWG screen in step 6 and the value read back are same value.
8. Disconnect the cable connected to the frequency counter.

DAC output waveform

This procedure verifies and adjusts for a minimal glitch on DAC output waveform.

NOTE. To make this adjustment you must remove the CH2 A70/A72 output board. Verify the glitch first, and then remove the board, and make the adjustment, if necessary.

Check

1. Do the following steps to install the test hookup and set up the test equipment controls:
 - a. Use a 50 Ω coaxial cable to connect the AWG400-Series CH1 output connector to the oscilloscope CH1 input connector. (see Figure 5–5).

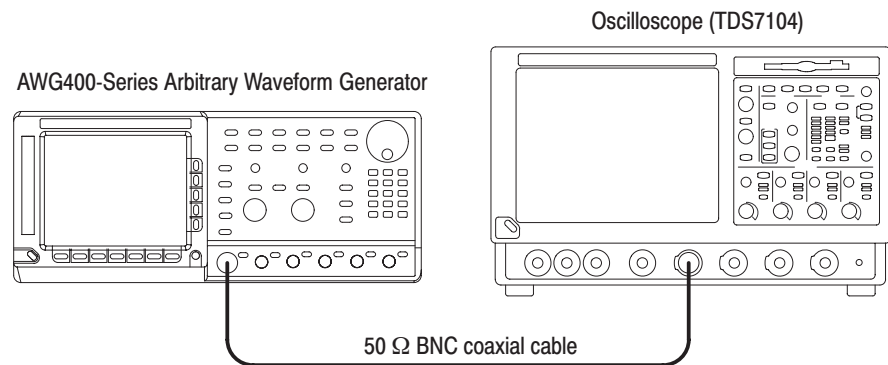

Figure 5–5: Continuous mode initial test hookup (Instrument with option 05)

- b. Set the oscilloscope controls as follows:

| | |
|---------------------|-------------|
| Vertical | CH1 |
| CH1 coupling | DC |
| CH1 scale | 0.2 V/div |
| CH1 input impedance | 50 Ω |
| Horizontal | |
| Sweep | 200 ns/div |
| Trigger | |
| Source | CH1 |
| Coupling | DC |
| Slope | Positive |
| Level | 0 V |
| Mode | Auto |

2. Set up the AWG400-Series, and load the waveform file:
 - a. Reset the AWG400-Series:
Push **UTILITY** (front-panel)→**System** (bottom)→**Factory Reset** (side)→**OK** (side).
 - b. Select the channel:
Push the desired channel select button **CH1** (left side of the front panel) for the channel that you want to verify.
 - c. Load the S130X2.WFM file for CH1.

Refer to *Loading Files* on page 4–10 for file loading procedures.
 - d. Select clock frequency:
Push **SETUP** (front-panel)→**Horizontal** (bottom)→**Clock** (side).
Push **2**, **0**, **0**, and **M** (SHIFT+7) keys in this order, or turn the general purpose knob to set the internal clock frequency to 200 MHz.
 - e. Set output level and mode:
Push **Vertical** (bottom)→ **Amplitude** (side).
Push **0**, **.**, and **5** keys in this order or turn the general purpose knob to set the amplitude to 0.5 V.
Push **Output** (side) → **Direct**.
3. Push the **RUN** and **CH1 OUTPUT** front panel buttons.
4. Verify the glitch on the sine wave that is displayed on the oscilloscope screen.

The next adjustment is performed when there is much glitch.

Adjust

NOTE. For the AWG420/AWG430, turn off the power switch, and remove the CH2 A70/A72 output board (see Figure 5–6).

5. The connections and settings are same as for step 1 and step 2.
6. Push the **RUN** and **CH1 OUTPUT** front-panel buttons.
7. Adjust R0417 on the A50 sequence board to minimize the glitch on the sine wave.

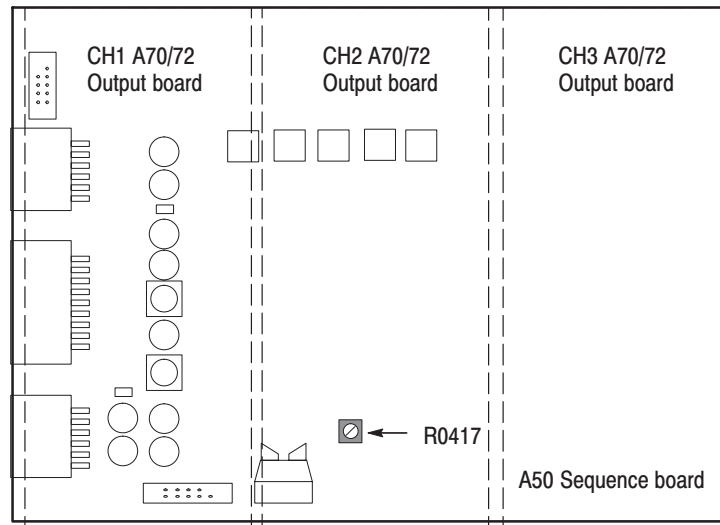

Figure 5-6: Adjustment location for the DAC output waveform

After Adjustment

8. Power off the AWG 400 Series, and install the CH2 A70/A72 output board.
9. Repeat step 2 through step 3 for CH2 and CH3 outputs (if applicable). Verify that the CH2 and CH3 glitches are same as the CH1 glitch.
10. Disconnect the oscilloscope.

Skew adjustment (AWG420/AWG430 only)

These procedures verify the channel skew function of the AWG400-Series.

| | |
|---------------------------|--|
| Equipment Required | Two 50 Ω BNC coaxial cables (Item 5), Two SMA-BNC adapter (Item 6), an SMA X5 Attenuator (Item 7), and an oscilloscope(TDS820). |
| Prerequisites | The AWG400-Series Arbitrary Waveform Generator must meet the prerequisites listed on page 4-8. |

NOTE. In this adjustment, the AWG400-Series is started in service mode. Refer to Enabling Service Mode on page 5-5 .

1. Do the following steps to install the test hookup and set the test equipment controls:
 - a. Use the 50 Ω BNC coaxial cables and SMA-BNC adapter to connect the AWG400-Series CH1 output to the oscilloscope CH1 input connector; use the SMA-BNC adapter and SMA X5 Attenuator to connect the AWG400-Series CH2 output to the oscilloscope TRIGGER INPUT connector (see Figure 5-7).

NOTE. Be sure to connect an attenuator for TRIGGER INPUT protection.

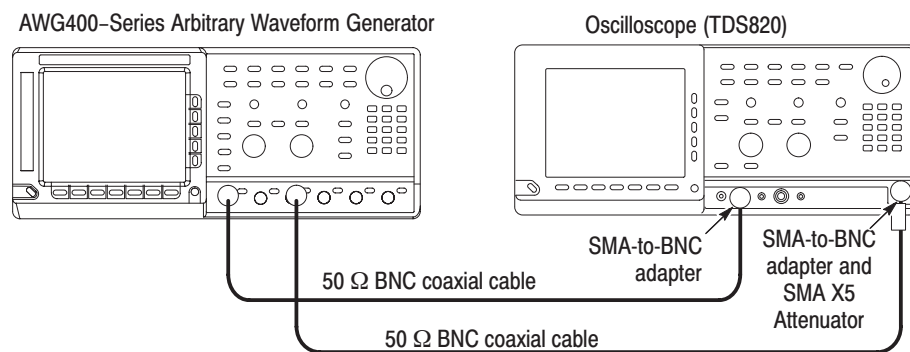

Figure 5-7: Channel skew test hookup

- b. Set the oscilloscope controls as follows:

| | |
|---|-------------------------|
| Vertical | CH1 |
| CH1 coupling | DC |
| CH1 scale | 250 mV/div |
| CH1 position | 0 Divs |
| CH1 offset | 0 V |
| Horizontal | |
| Record Length | 5000 points in 100 divs |
| Scale | 200 ps/div |
| Time Base position | |
| Main position | -1.5 ns |
| Trigger | |
| Source | External Input |
| Slope | Rise |
| Level | 0 V |
| Acquire mode | Auto |
| Display Variable Persistence mode | 500 ms |
| Cursor Vbars | On |

2. Follow the substeps below to set the AWG400-Series controls and select the waveform file:

a. Push **UTILITY** (front-panel)→**System** (bottom)→**Factory Reset** (side)→**OK** (side).

b. Load the DOUT.PAT file for CH1, CH2 and CH3.

Refer to *Loading Files* on page 4–10 for file loading procedures.

c. Push **SETUP** (front-panel)→**Horizontal** (bottom)→**Clock** (side).

d. Push **1, 0, 0** and **M** (SHIFT+7) keys in this order or turn the general purpose knob to set the internal clock frequency to 100 MS/s.

e. Push **Vertical** (bottom)→**Amplitude** (side).

f. Push **1** and **ENTER** keys in this order or turn the general purpose knob to set the amplitude to 1.0 V.

3. Push the **RUN** (front-panel), **CH1 OUTPUT**, **CH2 OUTPUT** and **CH3 OUTPUT**(front-panel) buttons.

■ Verify that $\overline{\text{CH1}}$, $\overline{\text{CH2}}$ and $\overline{\text{CH3}}$ outputs are off. If the $\overline{\text{CHx}}$ output is on, push **CHx OUTPUT** button to turn it off.

CH1 Skew Cal.

4. Follow the substeps below to set the AWG400-Series controls to the skew adjust menu:
 - a. Push **UTILITY** (front-panel)→**Service** (bottom)→**Tweak Awg2** (pop-up)→**OK** (side).
 - b. Push **CH1 Skew Cal...** (side), use the ▼ button to select **THRU**, and then push **Delay Setup** (side) buttons.
5. Set the oscilloscope controls:
 - a. Adjust the **Horizontal Position** knob on the oscilloscope so that the rising edge of pulse waveform is centered.
 - b. Set the active cursor position to the intersection of the rising edge of a pulse waveform and a horizontal axis.
 - c. Push the **TOGGLE** button to change the active cursor.

NOTE. From now on, do not adjust an inactive cursor, Trigger level, Vertical position, or the Main Position of the Time Base Position without directions.

6. Use the ▲ button to select the **Origin**, then push **Delay Setup** (side) button.
7. Adjust Origin parameter:
 - a. Rotate the **Horizontal Position** knob counterclockwise to show the rising edge of a pulse waveform
 - b. Set the active cursor position to the intersection of the rising edge of a pulse waveform and a horizontal axis.
 - c. Read the cursor delta (Δ) value and input this value in ps in the Origin frame of the AWG400 screen.
 - d. Push **OK** (side) button.

CH2 Skew Cal.

Change the test hookup as follows (see Figure 5–8).

8. Disconnect the cable connected to CH2 output, and connect it to CH1 MARKER OUT 1.
9. Set the oscilloscope controls as follows:

Trigger
 Level Press SET LEVEL TO 50% button

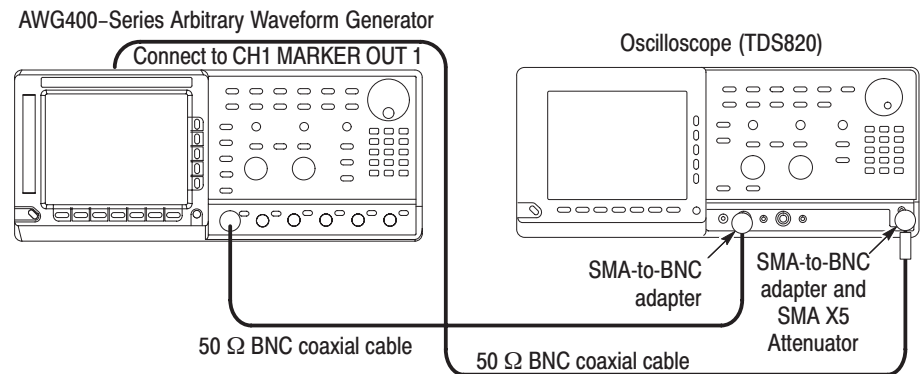

Figure 5-8: Channel skew test hookup for CH2 (1)

10. Push **CH2 Skew Cal...** (side), use the \blacktriangledown or \blacktriangle buttons to select **THRU**, and then push **Delay Setup** (side) buttons.
11. Set the position of the CH1 pulse waveform on the oscilloscope:
 - a. Set the **Horizontal Position** for the oscilloscope to **50%**, and adjust the position so that the rising edge of a CH1 pulse waveform is centered.
 - b. Set the active cursor position to the intersection of the CH1 rising edge of a pulse waveform and a horizontal axis.
12. Disconnect the cable connected to CH1 output of AWG400, and connect it to CH2 output of AWG400 (see Figure 5-9).

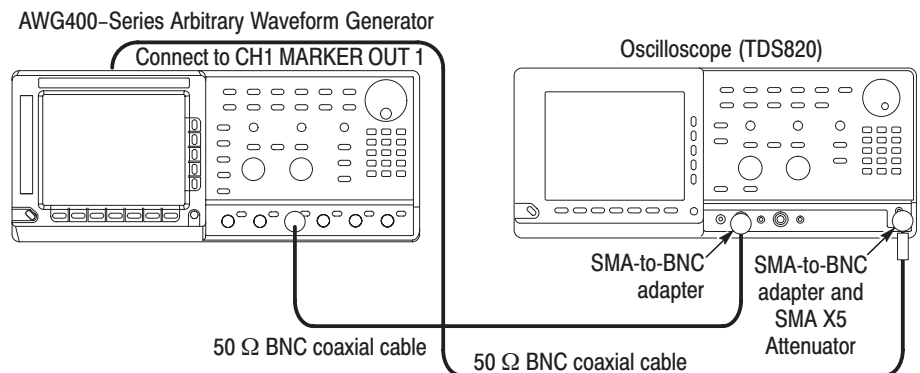

Figure 5-9: Channel skew test hookup for CH2 (2)

13. Focus on the CH2 pulse waveform:

- a. Push the **TOGGLE** button to change the active cursor.

NOTE. *From now, do not adjust an inactive cursor, Trigger level, Vertical position, or the Main Position of the Time Base Position without directions.*

- b. Set the active cursor position to the intersection of the rising edge of a CH2 pulse waveform and a horizontal axis.
- c. Read the cursor delta (Δ) value and input this value in ps in the THRU frame.

14. Adjust T0 parameter:

- a. Use the \blacktriangledown or \blacktriangle buttons to select **T0**, and then push **Delay Setup** (side) button.
- b. Rotate the **Horizontal Position** knob counterclockwise to show the rising edge of a CH2 pulse waveform.
- c. Set the active cursor position to the intersection of the rising edge of a pulse waveform and a horizontal axis.
- d. Read the cursor delta (Δ) value and input this value in ps in the T0 frame.

15. Adjust T1 to T8 parameters:

- a. Repeat step 14 a through d for T1 through T8.

16. Push **OK** (side)→ **Save Skew Calibration** (side)→ **Bitweight...** (side) (see Figure 5–10).

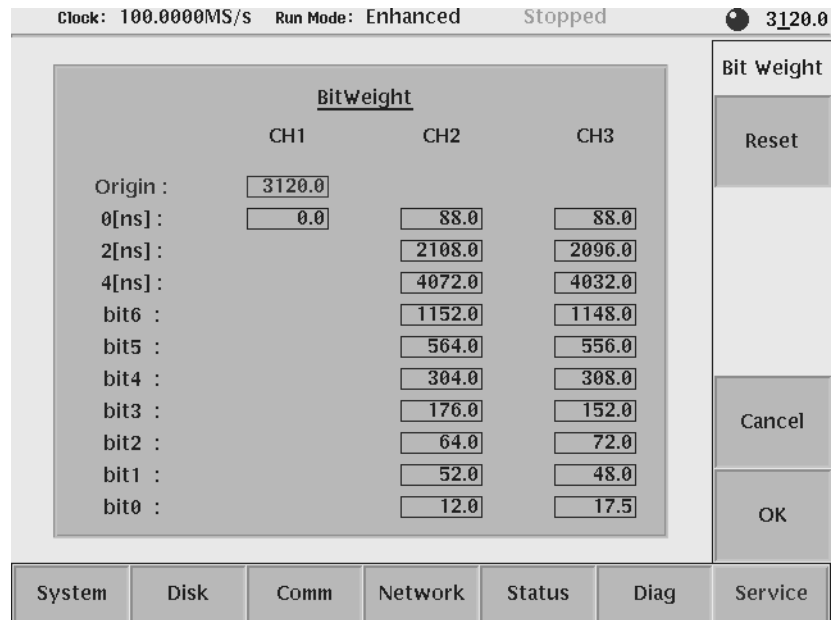

Figure 5-10: BitWeight table

17. Verify that the value of CH2 bit0 varies 8 to 20 ps.
18. Verify that the value is also increasing as bit0, bit1, bit2,... and a number become large. When the value is reversed, redo adjustment once again.
19. Push **OK** (side)→ **Save Skew Calibration** (side)

CH3 Skew Cal. (AWG430 only)

The test hookup is same as CH2 skew cal, except change the oscilloscope CH1 input cable connection from AWG CH2 output connector to CH3 output connector.

20. Disconnect the BNC cable at the AWG CH2 output connector, and then connect to the CH3 output connector (see Figure 5-11).

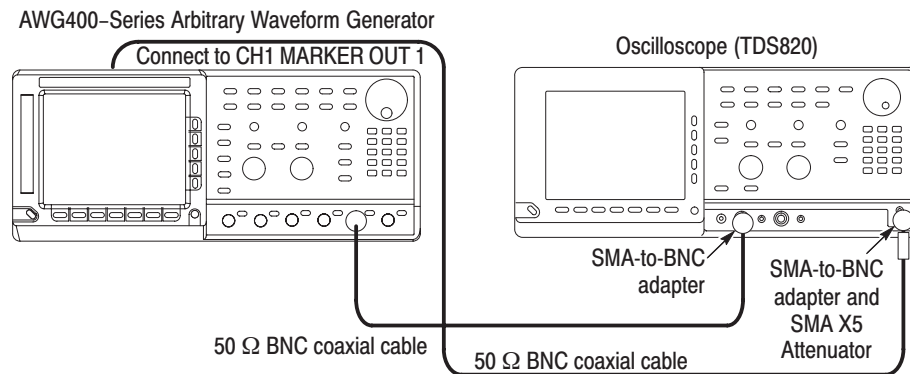

Figure 5-11: Channel skew test hookup for CH3

21. Push **CH3 Skew Cal...** (side), use the **▼** or **▲** buttons to select **THRU**, and then push **Delay Setup** (side) button.
22. Repeat steps 13 b through 19 for the CH3 signal.

NOTE. *It is not necessary to change the active cursor.*

23. Disconnect the cables.

Maintenance

This section contains the information needed to do periodic and corrective maintenance on the AWG400-Series Arbitrary Waveform Generator. The following subsections are included:

- **Related Maintenance Procedures** — Provides information about to various sections that have related maintenance information.
- *Preparation* — Introduction plus general information on preventing damage to internal modules when doing maintenance.
- *Inspection and Cleaning* — Information and procedures for inspecting the waveform generator and cleaning its external and internal modules.
- *Removal and Installation Procedures* — Procedures for the removal of defective modules and replacement of new or repaired modules.
- *Troubleshooting* — Information for isolating failed modules. Included are instructions for operating the internal diagnostic routines of the waveform generator and troubleshooting trees. Most of the trees make use of these internal diagnostic routines to speed fault isolation to a module.

Related Maintenance Procedures

The following sections contain information and procedures related to maintenance.

- The *Operating Information* section covers instructions useful when operating the waveform generator to troubleshoot it. It also details the service strategy and lists options for obtaining maintenance service and for replacing failed modules.
- The *Theory of Operation* section contains a circuit description at the module, or block, level.
- The *Performance Verification* section contains procedures that may be useful in isolating problems to modules by testing the waveform generator performance.
- The *Adjustment Procedures* section addresses after repair adjustment and the interval between periodic adjustments. It contains a procedure for adjusting the internal circuits of the waveform generator.
- The *Diagrams* section contains a block diagram using individual modules as blocks and an interconnection diagram showing connections between the modules.
- The *Replaceable Mechanical Parts* section, lists all field replaceable modules by part number.

Preparation

Before servicing this product, read the *Safety Summary* and *Introduction* at the front of the manual and the ESD information below.



CAUTION. *Static discharge can damage any semiconductor component in this generator.*

NOTE. *If you are removing a module for service, begin by doing the Access Procedure procedure on page 6–16. By following the instructions in that procedure, you remove the module to be serviced while removing the minimum number of additional modules.*

Preventing ESD

When performing any service which requires internal access to the waveform generator, adhere to the following precautions to avoid damaging internal modules and their components due to electrostatic discharge (ESD).

1. Minimize handling of static-sensitive modules.
2. Transport and store static-sensitive modules in their static protected containers or on a metal rail. Label any package that contains static-sensitive modules.
3. Discharge the static voltage from your body by wearing a grounded antistatic wrist strap while handling these modules. Do service of static-sensitive modules only at a static-free work station.
4. Do not allow anything capable of generating or holding a static charge on the work station surface.
5. Handle circuit boards by the edges when possible.
6. Do not slide the modules over any surface.
7. Avoid handling modules in areas that have a floor or work-surface covering capable of generating a static charge.

Susceptibility to ESD

Table 6–1 lists the relative susceptibility of various classes of semiconductors. Static voltages of 1 kV to 30 kV are common in unprotected environments.

Table 6–1: Relative susceptibility to static-discharge damage

| Semiconductor classes | Relative susceptibility levels ¹ |
|--|---|
| MOS or CMOS microcircuits or discrete circuits, or linear microcircuits with MOS inputs (most sensitive) | 1 |
| ECL | 2 |
| Schottky signal diodes | 3 |
| Schottky TTL | 4 |
| High-frequency bipolar transistors | 5 |
| JFET | 6 |
| Linear microcircuits | 7 |
| Low-power Schottky TTL | 8 |
| TTL (least sensitive) | 9 |

¹ **Voltage equivalent for levels (voltage discharged from a 100 pF capacitor through resistance of 100 ohms):**

| | |
|-------------------------|---------------------------------|
| 1 = 100 to 500 V | 6 = 600 to 800 V |
| 2 = 200 to 500 V | 7 = 400 to 1000 V (est.) |
| 3 = 250 V | 8 = 900 V |
| 4 = 500 V | 9 = 1200 V |
| 5 = 400 to 600 V | |

Inspection and Cleaning

Inspection and Cleaning describes how to inspect for dirt and damage. It also describes how to clean the exterior and interior of the AWG400-Series Arbitrary Waveform Generators. Inspection and cleaning are done as preventive maintenance. Preventive maintenance, when done regularly, may prevent waveform generator malfunctions and enhance its reliability.

Preventive maintenance consists of visually inspecting and cleaning the waveform generator and using general care when operating it.

How often to do maintenance depends on the severity of the environment in which the waveform generator is used. A proper time to perform preventive maintenance is just before generator adjustment.

General Care

The cabinet helps keep dust out of the waveform generator and should normally be in place when operating the generator. The front cover protects the front panel and display from dust and damage. Install the front cover when storing or transporting the waveform generator.

Inspection and Cleaning Procedures

Inspect and clean the waveform generator as often as operating conditions require. The collection of dirt on components inside can cause them to overheat and breakdown. (Dirt acts as an insulating blanket, preventing efficient heat dissipation.) Dirt also provides an electrical conduction path that could cause an generator failure, especially under high-humidity conditions.



CAUTION. *Avoid the use of chemical cleaning agents which might damage the plastics used in this waveform generator. Use only deionized water when cleaning the menu buttons or front-panel buttons. Use an ethyl alcohol solution as a cleaner and rinse with deionized water. Before using any other type of cleaner, consult your Tektronix Service Center or representative.*

Inspection — Exterior. Inspect the outside of the generator for damage, wear, and missing parts, using Table 6–2 as a guide. Waveform generators that appear to have been dropped or otherwise abused should be checked thoroughly to verify correct operation and performance. Immediately repair defects that could cause personal injury or cause further waveform generator damage.

Table 6–2: External inspection check list

| Item | Inspect for | Repair action |
|--------------------------------------|--|---|
| Cabinet, front panel, and cover | Cracks, scratches, deformations, damaged hardware or gaskets. | Repair or replace defective module. |
| Front-panel knobs | Missing, damaged, or loose knobs. | Repair or replace missing or defective knobs. |
| Connectors | Broken shells, cracked insulation, and deformed contacts. Dirt in connectors. | Repair or replace defective modules. Clear or wash out dirt. |
| Carrying handle, bail, cabinet feet. | Correct operation. | Repair or replace defective module. |
| Accessories | Missing items or parts of items, bent pins, broken or frayed cables, and damaged connectors. | Repair or replace damaged or missing items, frayed cables, and defective modules. |

Cleaning Procedure — Exterior. Do the following steps to clean the waveform generator exterior:

1. Remove loose dust on the outside of the waveform generator with a lint free cloth.
2. Remove remaining dirt with a lint free cloth dampened in a general purpose detergent-and-water solution. Do not use abrasive cleaners.
3. Clean the light filter protecting the monitor screen with a lint-free cloth dampened with either ethyl alcohol or, preferably, a gentle, general purpose detergent-and-water solution.



CAUTION. To prevent getting moisture inside the generator during external cleaning, use only enough liquid to dampen the cloth or applicator.

Inspection — Interior. To access the inside of the waveform generator for inspection and cleaning, refer to the *Removal and Installation Procedures* in this section.

Inspect the internal portions of the waveform generator for damage and wear, using Table 6–3 as a guide. Defects found should be repaired immediately.



CAUTION. To prevent damage from electrical arcing, ensure that circuit boards and components are dry before applying power to the waveform generator.

Table 6–3: Internal inspection check list

| Item | Inspect for | Repair action |
|--------------------|---|---|
| Circuit boards | Loose, broken, or corroded solder connections. Burned circuit boards. Burned, broken, or cracked circuit-run plating. | Remove failed module and replace with a new module. |
| Resistors | Burned, cracked, broken, blistered condition. | Remove failed module and replace with a new module. |
| Solder connections | Cold solder or rosin joints. | Resolder joint and clean with ethyl alcohol. |
| Capacitors | Damaged or leaking cases. Corroded solder on leads or terminals. | Remove damaged module and replace with a new module from the factory. |
| Semiconductors | Loosely inserted in sockets. Distorted pins. | Firmly seat loose semiconductors. Remove devices that have distorted pins. Carefully straighten pins (as required to fit the socket), using long-nose pliers, and reinsert firmly. Ensure that the straightening action does not crack pins, causing them to break off. |
| Wiring and cables | Loose plugs or connectors. Burned, broken, or frayed wiring. | Firmly seat connectors. Repair or replace modules with defective wires or cables. |
| Chassis | Dents, deformations, and damaged hardware. | Straighten, repair, or replace defective hardware. |

Cleaning Procedure — Interior. Do the following steps to clean the generator interior:

1. Blow off dust with dry, low-pressure, deionized air (approximately 9 psi).
2. Remove any remaining dust with a lint-free cloth dampened in ethyl alcohol and rinse with warm deionized water. (A cotton-tipped applicator is useful for cleaning in narrow spaces and on circuit boards.)

NOTE. *If, after doing steps 1 and 2, a module is clean upon inspection, skip the remaining steps.*

3. If steps 1 and 2 do not remove all the dust or dirt, the waveform generator may be spray washed using a solution of ethyl alcohol by doing steps 4 through 8.
4. Gain access to the parts to be cleaned by removing easily accessible shields and panels (see *Removal and Installation Procedures*).
5. Spray wash dirty parts with the ethyl alcohol and wait 60 seconds for the majority of the alcohol to evaporate.
6. Use hot (120° F to 140° F) deionized water to thoroughly rinse boards and components.
7. Dry all parts with low-pressure, deionized air.
8. Dry all components and assemblies in an oven or drying compartment using low-temperature (125° F to 150° F) circulating air.

Lubrication. There is no periodic lubrication required for the waveform generator.

Removal and Installation Procedures

This subsection contains procedures for removal and installation of all mechanical and electrical modules. Any electrical or mechanical module, assembly, or part listed in the *Replaceable Mechanical Parts* section of this manual is a module.

Preparation for Use



WARNING. Before doing this or any other procedure in this manual, read the *Safety Summary* at the beginning of this manual. Also, to prevent possible injury to service personnel or damage to components, read *Operating Information: Installation and Preventing ESD* in this section.

This subsection contains the following items:

- This preparatory information that you need to properly do the procedures that follow.
- A list of tools that are required to remove and disassemble all modules.
- Three module-locator diagrams for finding the External Modules (see Figure 6–2), Outer-Chassis Modules (see Figure 6–3), and Inner-Chassis Modules (see Figure 6–5).
- Procedures for removal and installation of the electrical and mechanical modules.
- A disassembly procedure for removal of all the major modules from the waveform generator at one time and for reassembly of those modules. A complete disassembly is normally only done when completely cleaning the waveform generator. (Instructions for doing the actual cleaning are found under *Inspection and Cleaning* at the beginning of this section.)
- Module disassembly procedures.



WARNING. To prevent serious injury or death, disconnect the power cord from the line voltage source before doing any procedure in this subsection.

List of Modules

The *Replaceable Mechanical Parts* section lists all modules.

Summary of Procedures

The following procedures are described in the order in which they appear in this section.

- The *Access Procedure* on page 6–16 directs you to the procedure(s) (if any) that are required to access the module to be serviced, and then it directs you to the procedure to remove that module.
- *Procedures for External Modules* on page 6–17 are procedures for removing modules that do not require internal access to the waveform generator.
- *Procedures for Internal Modules (1)* on page 6–30 are procedures for removing modules which require access to the internal part of the waveform generator but external to the chassis.
- *Procedures for Internal Modules (2)* on page 6–44 are procedures for removing modules which require access to the internal part of the waveform generator and internal to the chassis.

Equipment Required. Most modules in the waveform generator can be removed using a screwdriver with a #2 Phillips tip (see Table 6–4). Use this tool whenever a procedure step instructs you to remove or install a screw unless a different size screwdriver is specified in that step. All equipment required to remove and install a module are listed in the first step of each procedure.

Table 6–4: Tools required for module removal

| Item no. | Name | Description |
|----------|------------------------|---|
| 1 | Screwdriver handle | Accepts Phillips-driver bits |
| 2 | #1 Phillips tip | Phillips-driver bit for #1 screw size |
| 3 | #2 Phillips tip | Phillips-driver bit for #2 screw size |
| 4 | Flat-blade screwdriver | Screwdriver for removing slotted screws |
| 5 | Needle-Nose Pliers | Standard tool |
| 6 | Nutdriver, ½ inch | Standard tool |
| 7 | Nutdriver, 5 mm | Standard tool |
| 8 | Nutdriver, 7 mm | Standard tool |
| 9 | Retaining Ring Pliers | Standard tool |
| 10 | Angle-Tip Tweezers | Standard tool |
| 11 | Soldering Iron | Standard tool |
| 12 | Pliers | Standard tool |
| 13 | Solder Wick | Standard tool |
| 14 | Adhesive | TRA-CON: Tra-Bond #BA-2114 |

Instrument Orientation

The procedures refer to “front,” “right,” “top,” and so on. of the waveform generator. Figure 6–1 shows how the sides are referenced.

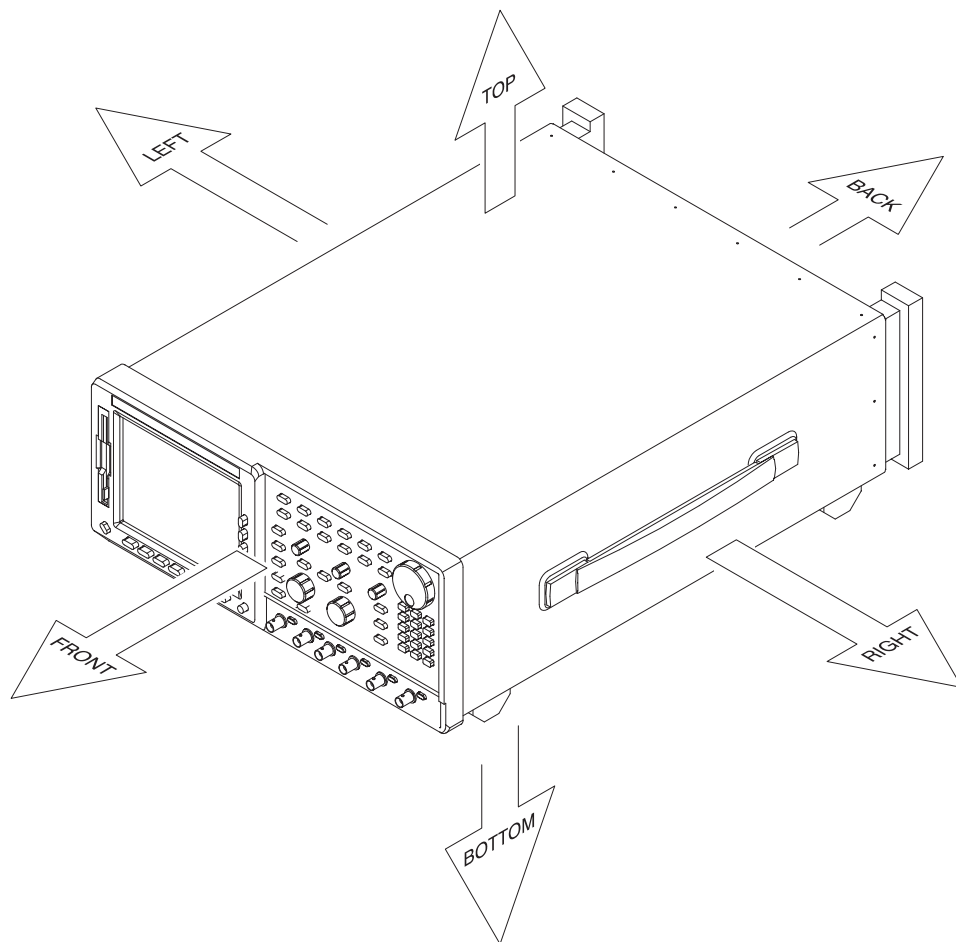

Figure 6–1: Instrument orientation

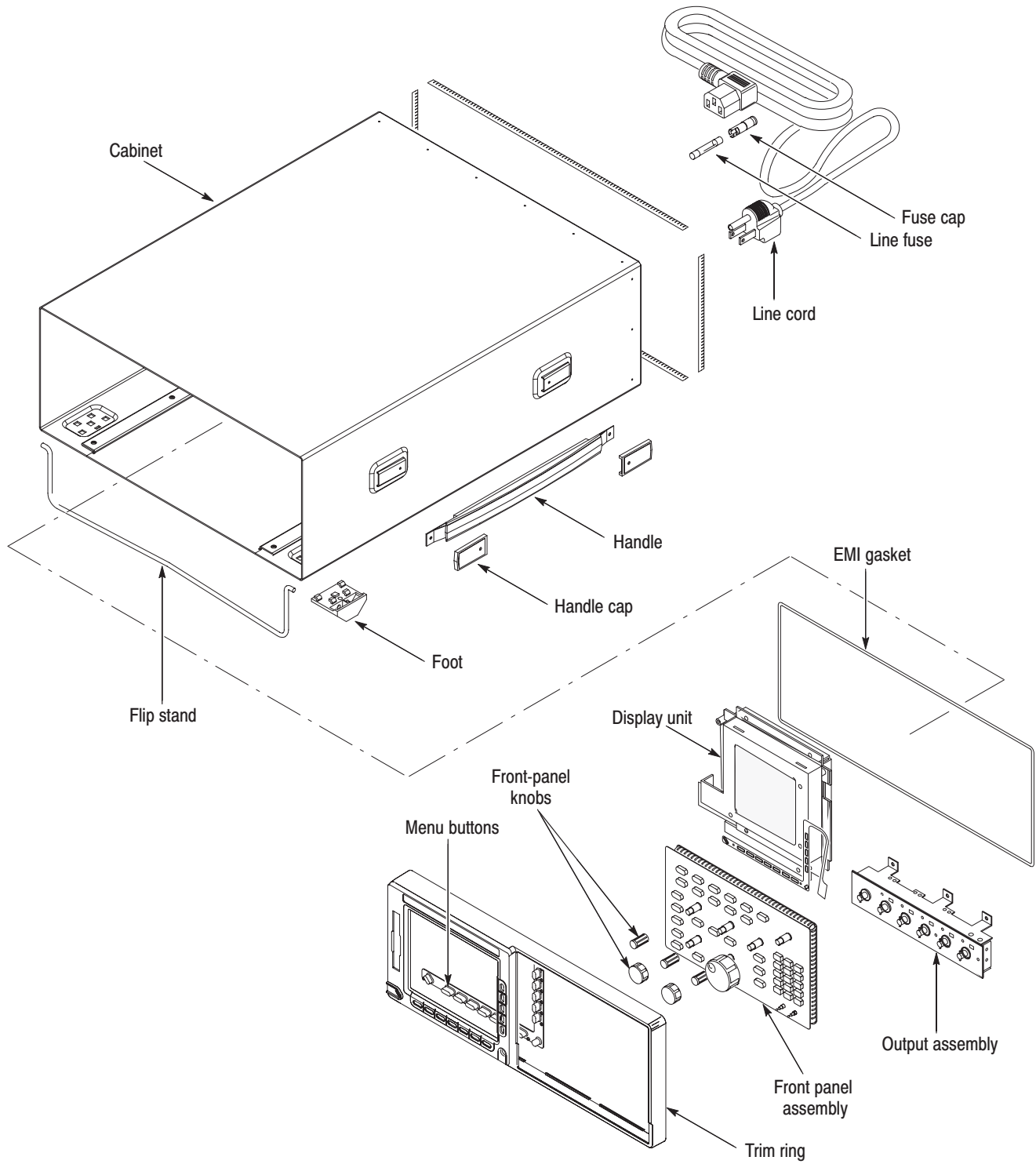

Figure 6-2: External modules

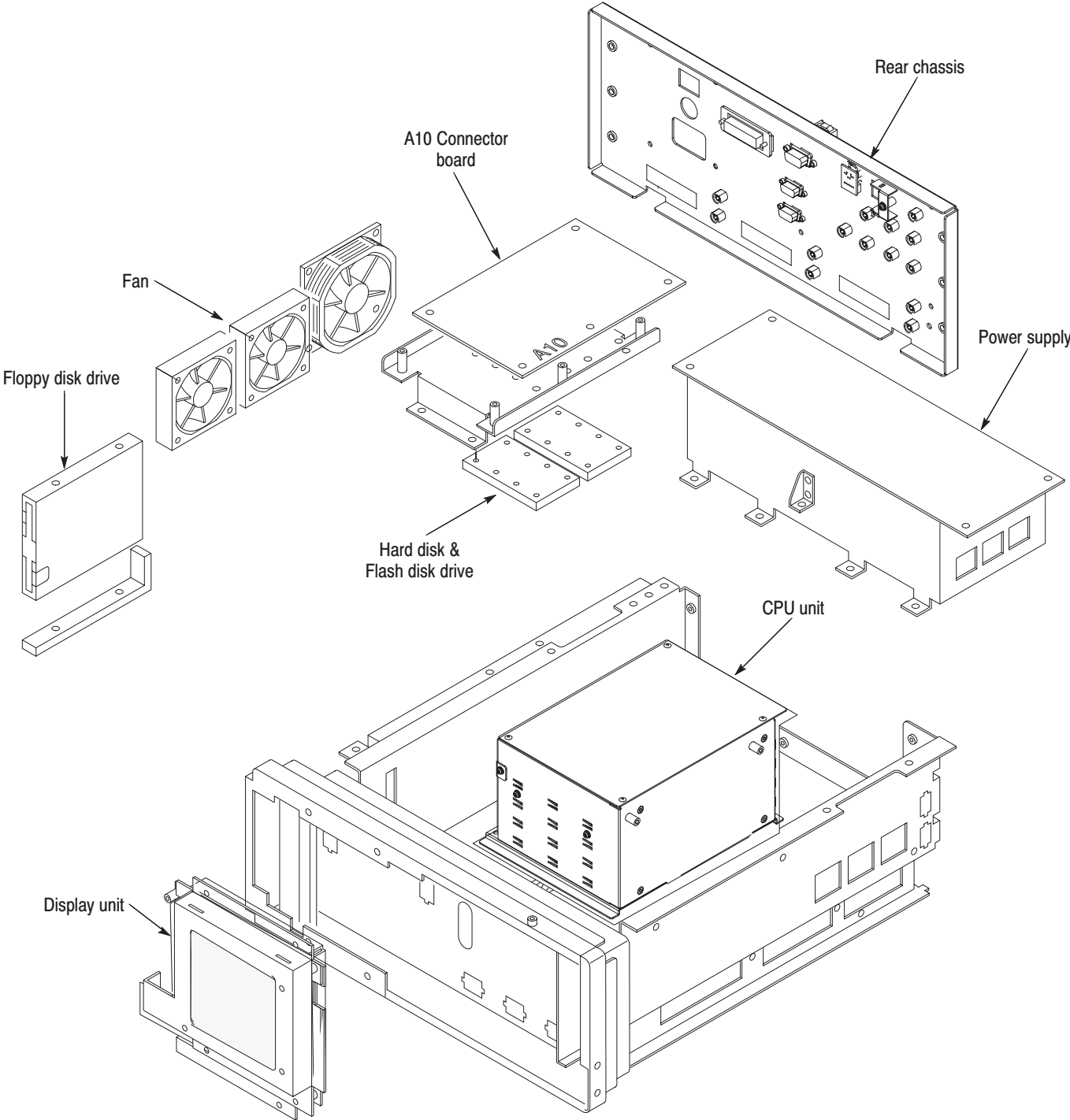

Figure 6-3: Internal modules (1)

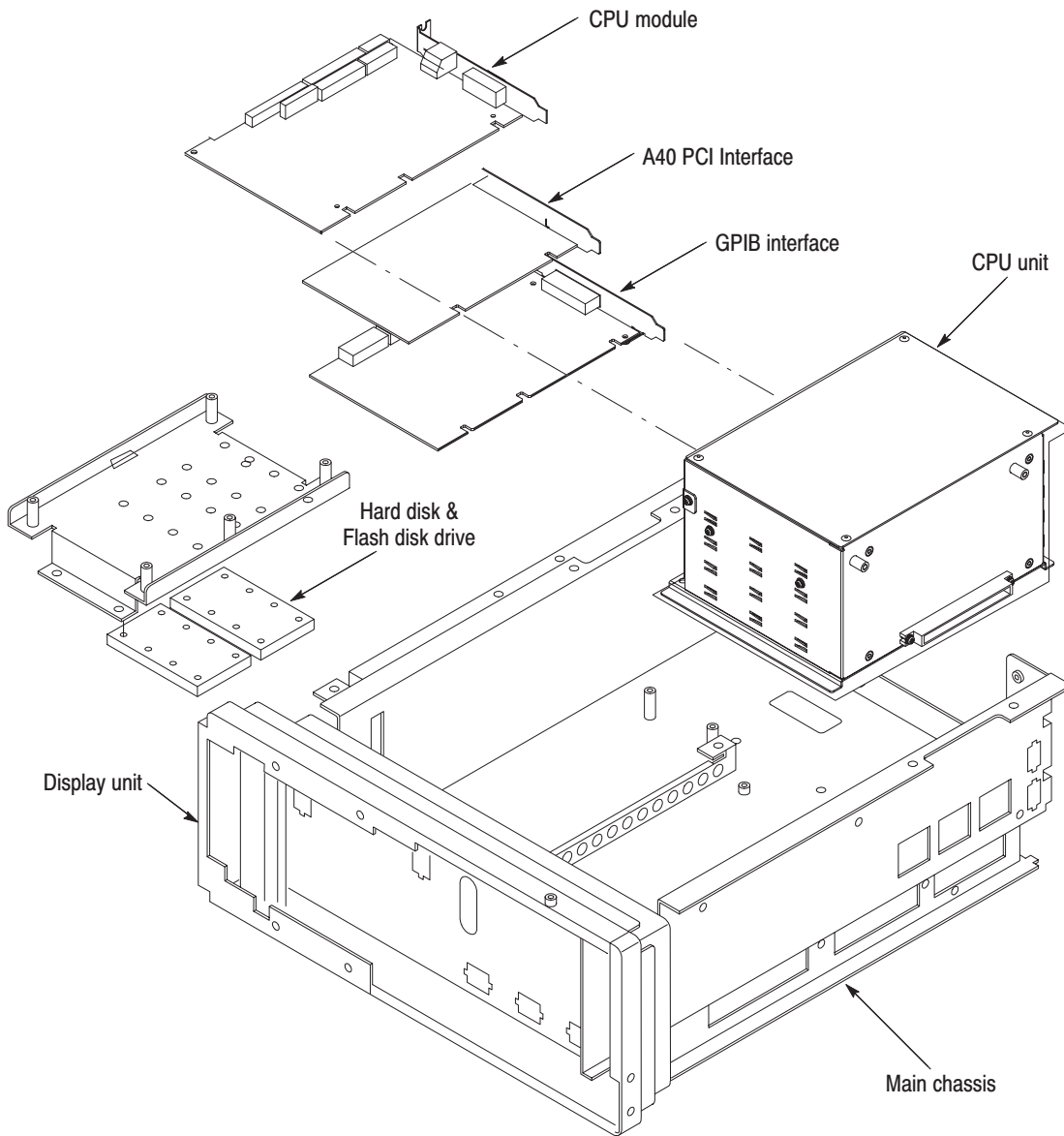

Figure 6-4: Internal modules(1)

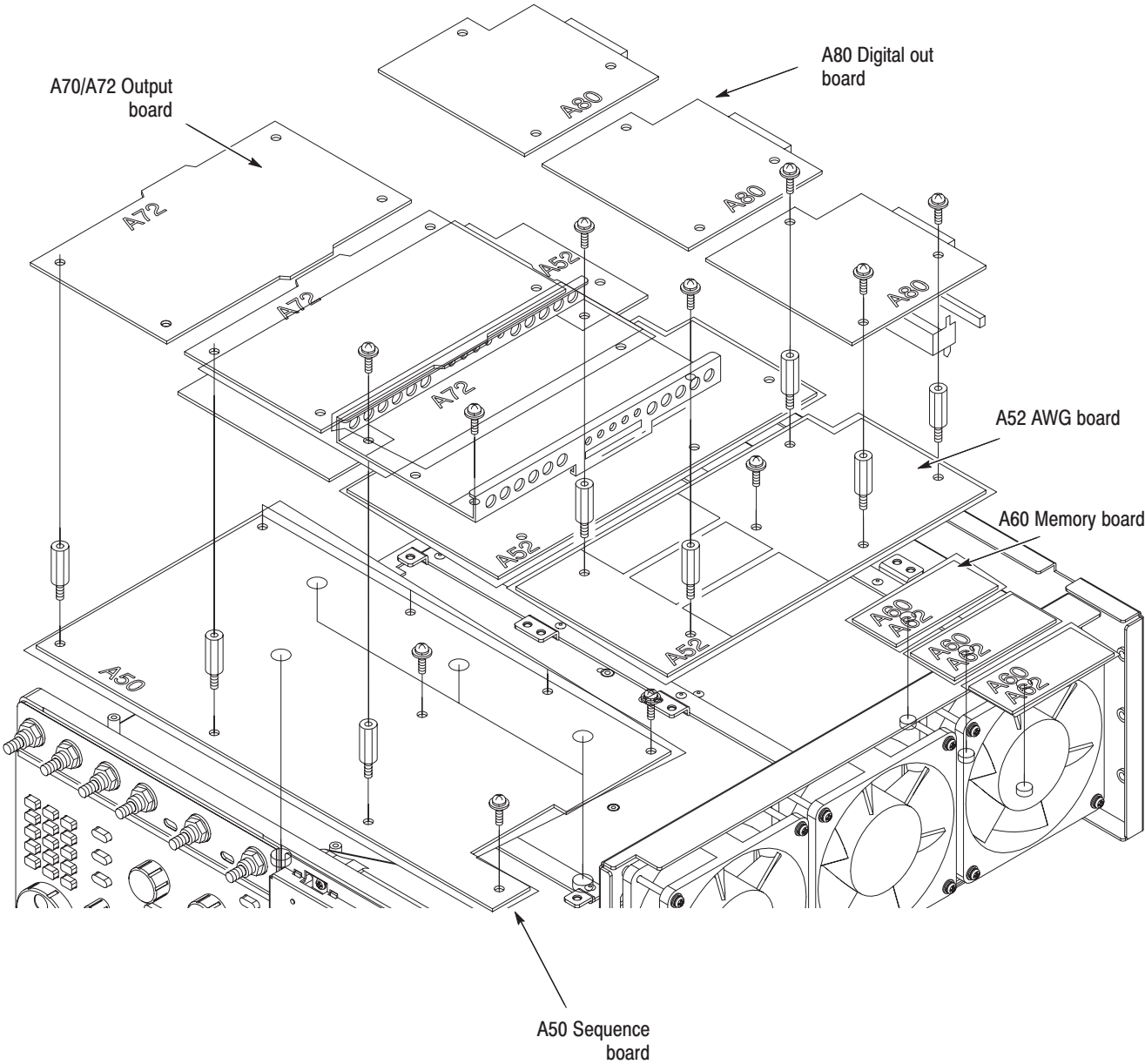

Figure 6-5: Internal modules(2)

Access Procedure

Begin with this procedure when you have identified a module to be removed for service.

1. Find the module to be removed in Figures 6–2 through 6–5.

The title of the figure indicates whether the module is an external, internal module (1), or internal module (2) part.

2. If the module is externally mounted and no internal access is required, remove the module. Locate the necessary procedure in the *Procedures for External Modules* on page 6–17.
3. If the module is an internal-chassis module and access is required inside of the instrument, do the *Line Fuse and Line Cord* procedure, and then do the *Cabinet* procedure. Both procedures are in the *Procedures for External Modules* subsection.
4. After completing those procedures, return to this procedure and continue with step 5.
5. If the module is an internal module(1), access the inner-chassis.
 - a. If removing the output assembly or display unit, first do the procedure *Trim Ring* found under *Procedures for External Modules* (page 6–17).
 - b. Find and do the procedure for the module to be removed under *Procedures for Internal Modules (1)* on page 6–30.
6. If the module is an internal module (2), access the reverse side of the chassis.
 - a. Since the ECB module is assembled by three classes, there is a removal order.
 - b. Find and do the procedure for the module to be removed under *Procedures for Internal Modules (2)*, page 6–44.
 - c. Do the procedure *A10 Connector Board* found under *Procedures for Internal Modules (1)*, page 6–30.
7. Install all modules previously removed. Read the instructions found at the end of the procedure that removes the module to be serviced. These instructions will guide you in installing all modules previously removed.

Procedures for External Modules

Do the *Access Procedure* on page 6–16, before doing any procedure in this collection.

The following procedures are listed in order presented.

- *Front-Panel Knobs*
- *Line Fuse and Line Cord*
- *EMI Gaskets*
- *Cabinet*
- *Trim Ring*
- *A20 Front-Panel Assembly*
- *Output Assembly*
- *Cabinet Modules*

Front Panel Knobs

You will need an angled-tip tweezers (Item 10).

1. Find the knob(s) to be removed on the front panel.
2. Orient the waveform generator so its bottom is down on the work surface and its front is facing you.
3. Remove the knob(s) by pulling it straight out from the front panel slightly to create some clearance between the base of the knob and the front panel. Insert the tweezers between the knob and front panel, and use them to remove the knob. See Figure 6–6.
4. To install, align knob to shaft and push it in until it snaps into place.

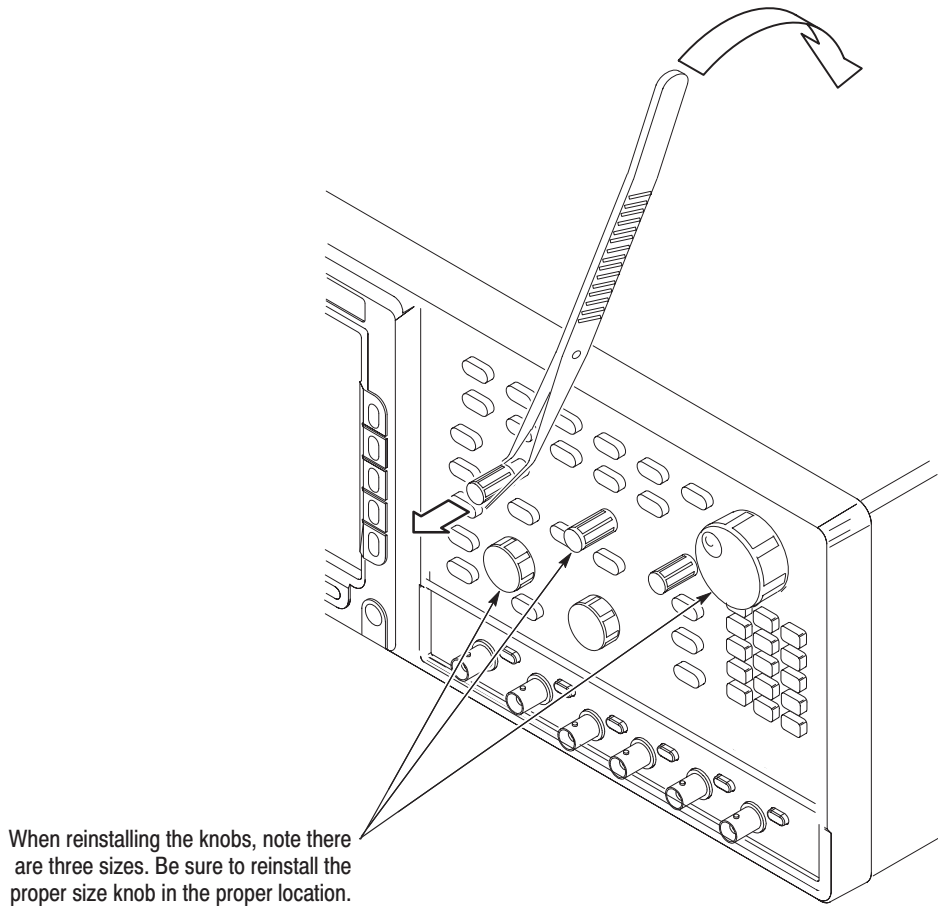

Figure 6-6: Knob removal

Line Fuse and Line Cord

You will need a flat-blade screwdriver (Item 4). Locate the line fuse and line cord (see Figure 6-2).

1. Orient the generator so its bottom is down on the work surface and its rear is facing you. If you are servicing the line fuse, do the next step; if you are servicing the line cord, skip to step 3.
2. Find the fuse cap on the rear panel. See Figure 6-7. Remove the fuse cap by turning it counterclockwise using a flat-blade screwdriver, and remove the line fuse.
3. Find the line cord on the rear cover. See Figure 6-7. Pull the line cord to complete the removal. Reverse the procedure to install the line cord.
4. Do in reverse steps 2 and 3 to install the line cord and then the line fuse.

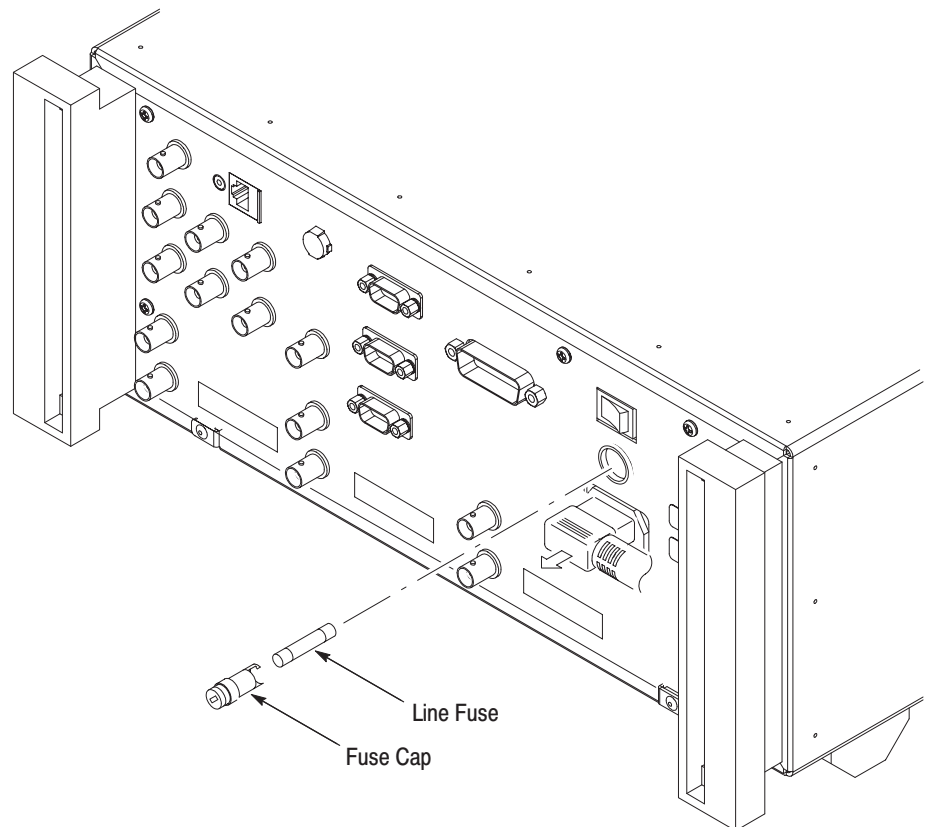

Figure 6-7: Line fuse and line cord removal

EMI Gaskets See cabinet procedure below.

Cabinet You will need a screwdriver with a Phillips #2 tip (Items 1 and 3).

1. Make sure the front cover (optional accessory) is installed; if it's not, install it by snapping its edges over the trim ring.
2. Locate the cabinet (see Figure 6–2, page 6–12).
3. Orient the waveform generator so that its face is down with its front cover on the work surface and its bottom is facing you (see Figure 6–4).
4. Unplug the line cord from its receptacle at the rear cover.
5. Remove the six screws at the rear of the cabinet that are securing the two feet.
6. Grasp the left and right edges at the rear of the cabinet.
7. Pull upward to slide the cabinet off the waveform generator. Take care not to bind or snag the cabinet on the internal cabling as you remove it.

NOTE. Do not do steps 8 through 13 to remove the EMI gasket(s) unless the gaskets must be replaced due to damage. If you are not replacing these gaskets, skip to step 14.

When installing EMI gaskets and/or the cabinet, carefully follow the instructions given. Unless they are performed properly, the waveform generator may not meet its emissions requirements (EMI).

8. Locate the EMI gaskets to be removed (see Figure 6–2 on page 6–12).

You will need a pair of needle-nose pliers (Item 6).

9. Look for the point where the ends of the gasket touch in the channel at the rear edge of the cabinet.
10. Use a pair of needle-nose pliers to pry up one of the ends.
11. Grasp the EMI gasket, and gently pull it out of its channel.
12. Repeat substeps 9 through 11 to remove the gasket from its channel on the front casting.
13. To install, press each EMI gasket back into its groove at the rear edge of the cabinet or front casting. Make sure the ends of the gasket touch, but do not overlap, when installing. Cut off excess length if required to prevent overlap.
14. To install the cabinet, do steps 3 and 4 in reverse order.

- a. Take care not to bind or snag the cabinet on internal cabling; redress cables if necessary.
- b. When sliding the cabinet, be sure that the front edge of the cabinet aligns with the groove containing the EMI shield on the front casting.
- c. Be sure that the ridge around the rear chassis slides into the groove containing a second EMI cable on the rear of the cabinet.
- d. When installing the four screws at the rear panel, tighten them to 16 foot-lbs torque.
- e. See the procedure *Line Fuse and Line Cord* to install the line cord.

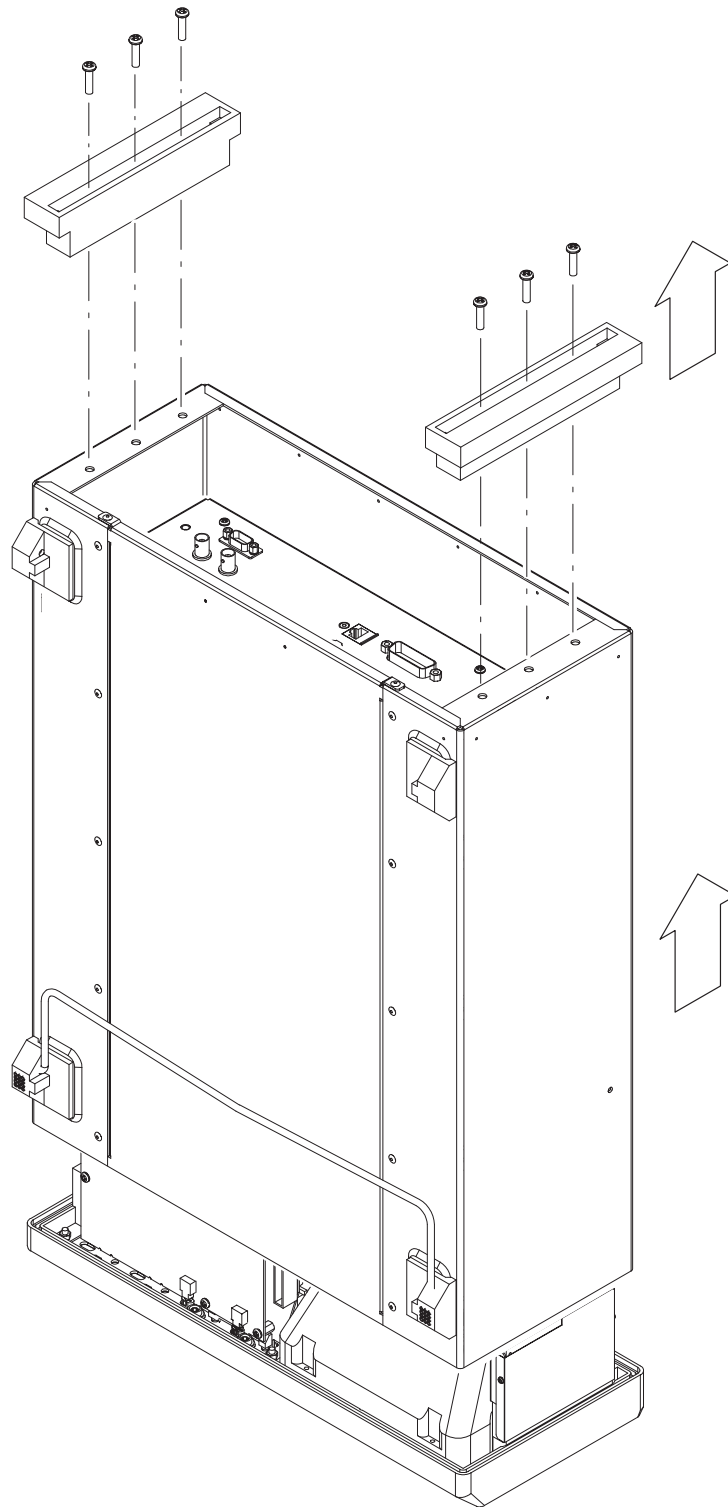

Figure 6-8: Cabinet removal

Trim Ring

No tools are needed for this procedure.

1. Locate the modules to be removed (see Figure 6-2 on page 6-12).
2. Orient the waveform generator so that its rear is down on the work surface and its bottom is facing you.
3. Remove the front cover by grasping the front cover by its left and right edges and snap it off of the front subpanel. When installing, align and snap back on. See Figure 6-9.

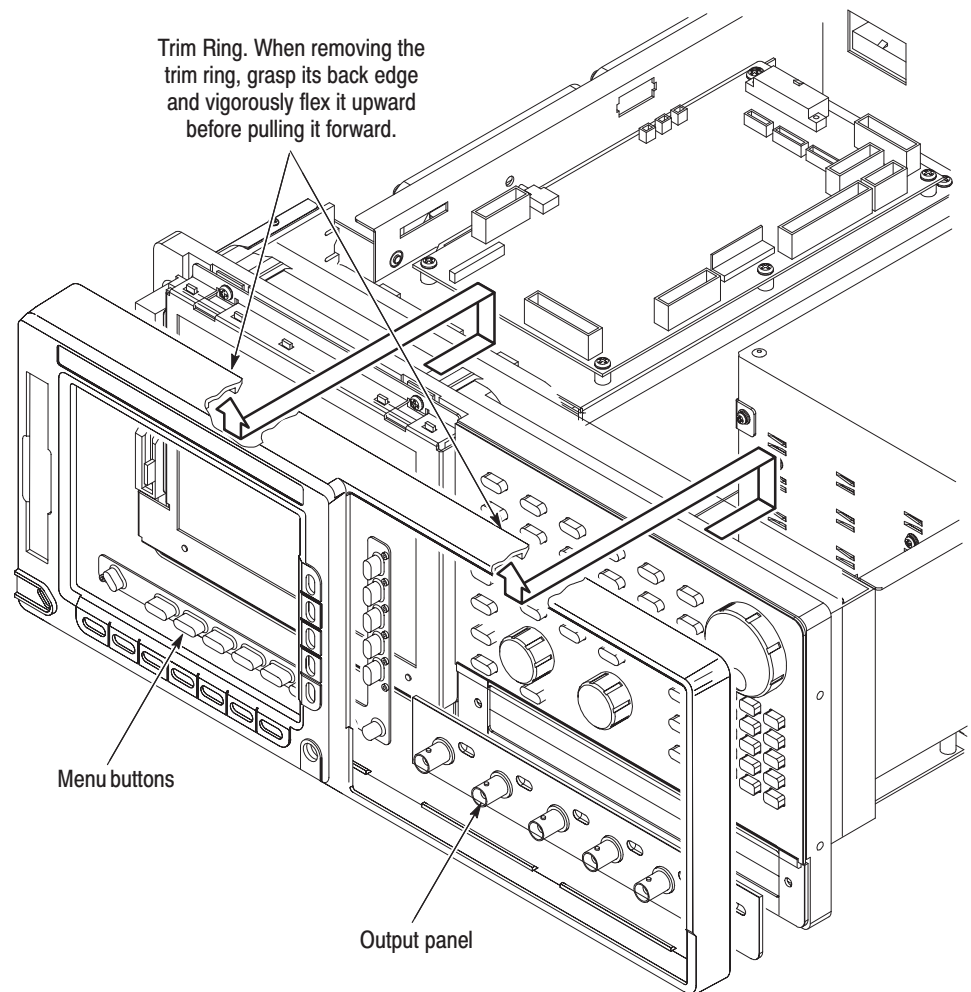

Figure 6-9: Trim ring and menu buttons removal

NOTE. Do not touch the carbon contact points on the menu buttons installed in the trim ring. Also, do not touch the contacts on the flex circuit exposed when you remove the trim ring.

4. Remove the trim ring by grasping its top edge, prying it up, and lifting it forward to snap it off of the front subpanel. If servicing the menu buttons, lift them out of the trim ring. When installing, insert the menu buttons, align the trim ring to the front subpanel and press it back on.
5. To install the output panel, menu buttons, and trim ring, do steps 3 through 4 in reverse.

A20 Front-Panel Assembly

This procedure includes removal and installation instructions for the front panel and front-panel buttons. Unless either of those modules are being serviced, do not do step 4.

You will need a screwdriver with a Phillips #2 tip (Items 1 and 3).

1. Locate the modules to be removed (see Figure 6–2 on page 6–12).
2. Do the procedure *Trim Ring* steps 1 to 5, immediately preceding this procedure.
3. Orient the waveform generator so that its bottom is down on the work surface and its front is facing you.
4. Remove the front-panel assembly out of the front subpanel by lifting the assembly until you can reach the interconnect cable connecting to the Connector board.
5. Disconnect the cable at J154 of the Connector board. Disconnect the flex-board connector at P3 of the Front-Panel assembly. (The flex board is part of the display-frame assembly). See Figure 6–10.
6. Lift the Front-Panel assembly out of the front subpanel to complete the removal.

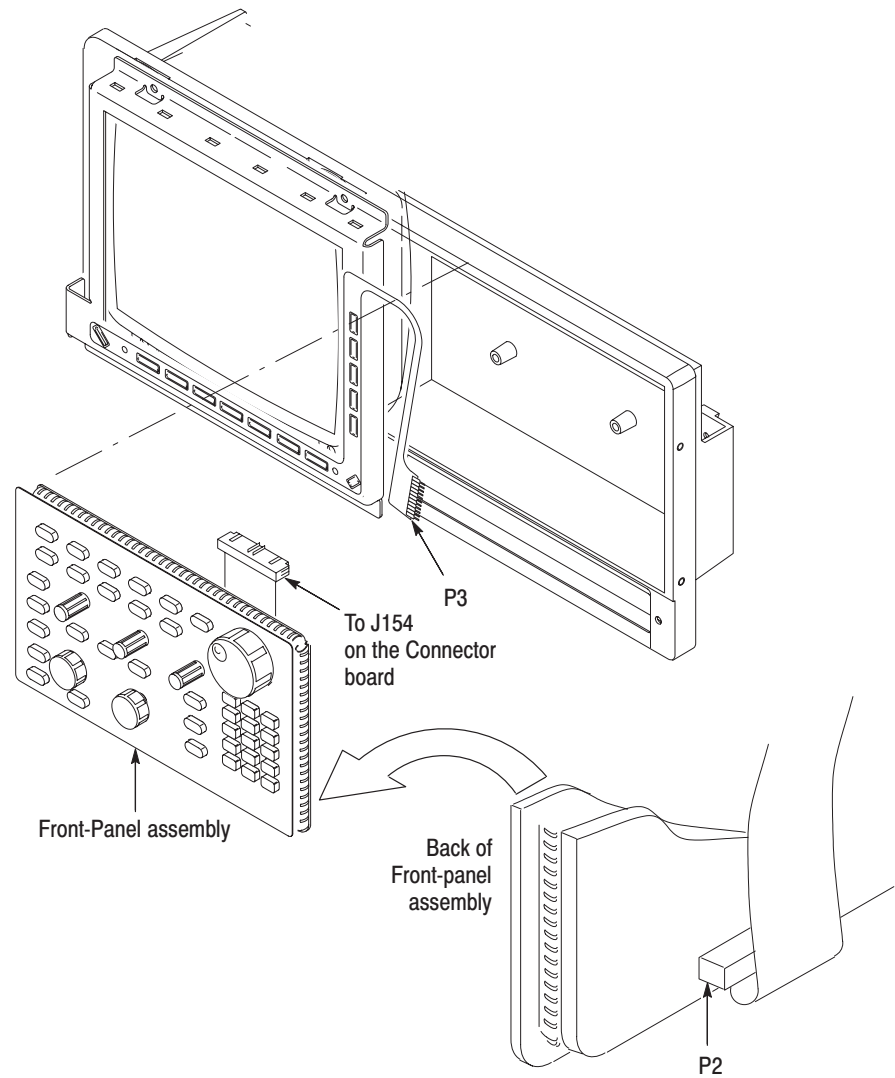

Figure 6-10: A20 Front-Panel assembly removal

If the front panel or the front-panel buttons are to be serviced, do the following steps:

7. Remove the front-panel control knobs from the front-panel assembly using the method described in *Front-Panel Knobs* on page 6-17.
8. Remove the eight screws mounting the front-panel board to the front panel.
9. Hand disassemble the front-panel assembly components using Figure 6-11 as a guide. Do this procedure in reverse to reassemble using Figure 6-11 as a guide.
10. To install, reverse this procedure.

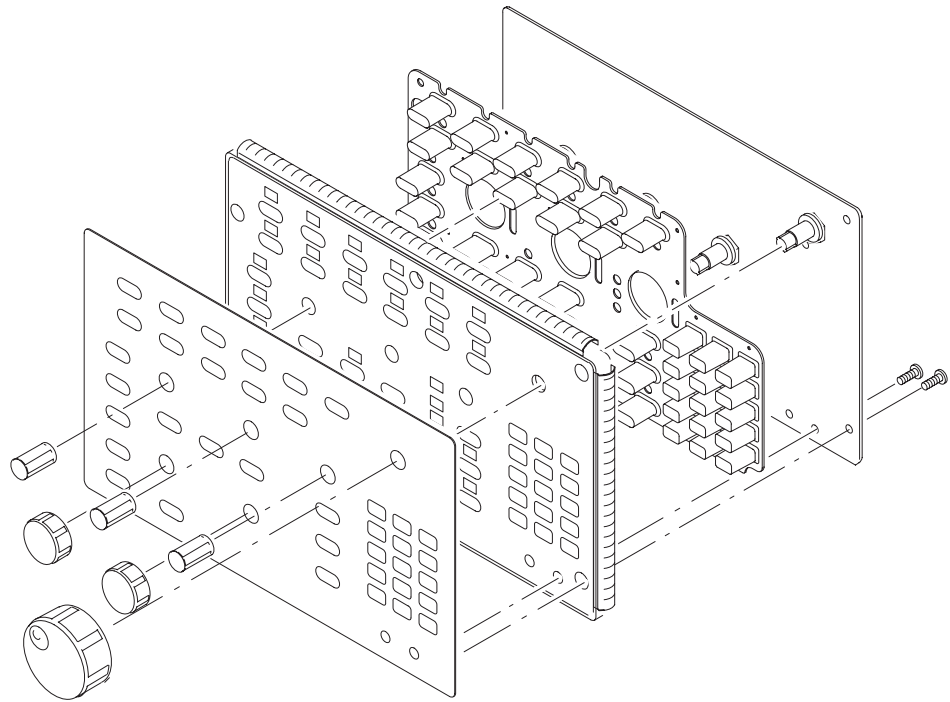

Figure 6-11: Disassembly of Front-Panel assembly

Output Assembly

You will need a screwdriver with a Phillips #2 tip (Items 1 and 3).

1. Locate the modules to be removed (see Figure 6-2 on page 6-12).
2. Do the procedure *Trim Ring and A20 Front panel assembly* immediately preceding this procedure.
3. Orient the waveform generator so its bottom is down on the work surface and its front is facing you.
4. To remove the output panel, disconnect the on/off cable at J200 of the A50 Sequence board and all the Analog output cables at J190 and J290 of each A70/A72 Output boards.
5. Remove the three screws at the front side of the chassis and the two screws at the bottom side of the chassis attaching the Output assembly to the main chassis.
6. Pull out the Output assembly from the main chassis.

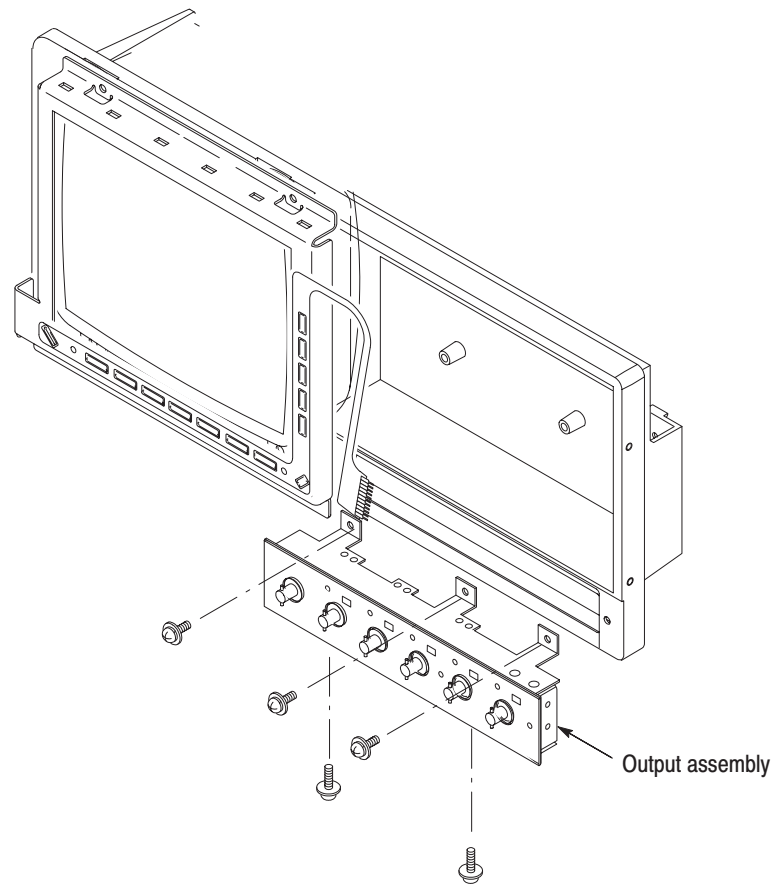

Figure 6-12: Output assembly removal

7. To install, reverse this procedure.

Cabinet Modules

You will need a pair of needle-nose pliers (Item 5).

1. Locate the modules to be removed in Figure 6-2, page 6-12.
2. Orient the waveform generator so that the left side is down on the work surface and its handle is facing upwards.
3. Remove the handle by inserting the tips of a pair of needle-nose pliers (Item 5) into the hole of either handle cap. Push and hold to depress the handle release.
4. While holding the handle release, pull it out of the slot in the handle cap. Repeat procedure to remove the handle from the other handle cap.
5. To install, reverse this procedure.

6. Remove the handle caps by inserting the retaining ring pliers (Item 9) into the opening created in the handle cap when you removed the handle.
7. While using the pliers to expand the handle cap outward, grasp it and snap it off.
8. Repeat procedure to remove the remaining cap as needed; push the cap(s) back on to install.
9. Remove the flip stand by grasping the flip stand by both sides near where it joins each flip stand foot. Now compress the flip stand until the flip stand ends clear the flip stand feet to complete the removal.
10. To remove the flip stand foot or feet, do the *Cabinet* procedure (page 6–20) to gain access to inside of the cabinet.
11. Working from inside the cabinet, push the two retainers to release the flip stand foot you wish to remove, and lift it away from the outside of the cabinet.
12. Repeat this procedure to remove as many of the remaining feet as needed. Insert the two retainers back in their slots in the cabinet, and snap any flip stand foot, previously removed, into place.
13. To install, reverse this procedure.

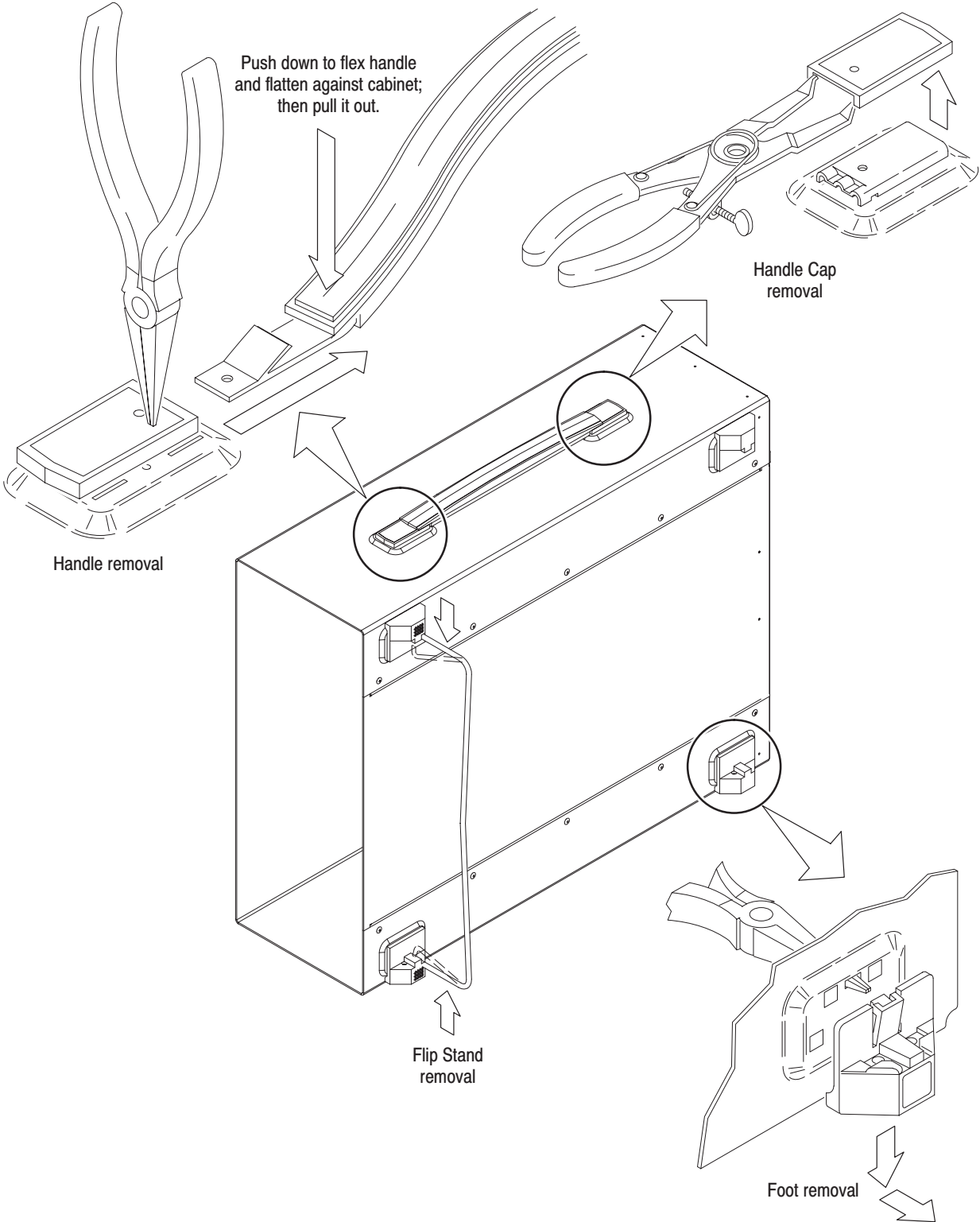

Figure 6-13: Cabinet modules removal

Procedures for Internal Modules (1)

You should have completed the *Access Procedure* before doing any procedure in this collection. This section describes removal/installation procedures for the following modules:

- *Fan*
- *Floppy disk drive*
- *Display Assembly*
- *PS100 Low Voltage Power Supply*
- *A10 Connector Board*
- *CPU unit*
 - *CPU Board*
 - *A40 PCI Interface Board*
 - *GPIB Board*
 - *Back Plane Board*
- *Hard disk and Flash disk*
- *Rear Chassis*

- Fan** You will need a screwdriver with a #2 Phillips tip (Items 1 and 3).
1. Locate the fan (see Figure 6-3 on page 6-13).
 2. Orient the waveform generator so that its bottom is down on the work surface and its left side is facing you (see Figure 6-14).
 3. Slide the cable connector at the fan to unplug the cable from the Connector board at J310.
 4. Remove the four screws that secure the fan to the main chassis, and lift the fan away. One large fan uses a spacer post.
 5. To install, do the steps in reverse order. Refer to the *Cabinet* procedure, on page 6-20, to complete assembly of the waveform generator.

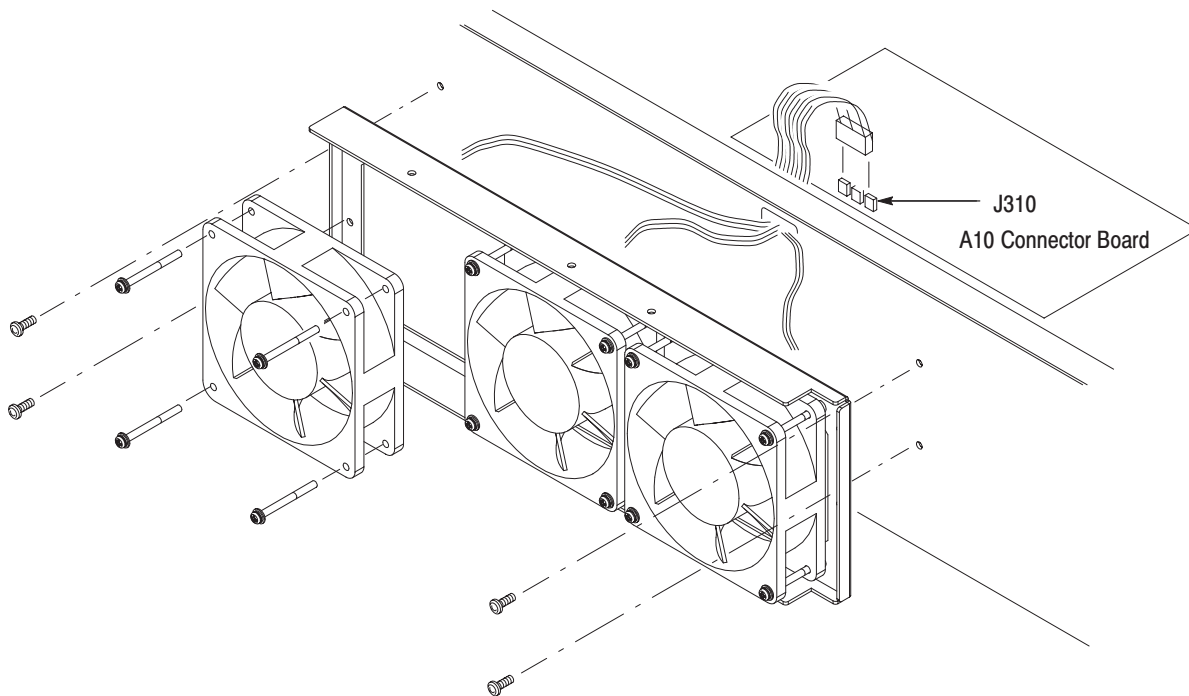

Figure 6-14: Fan removal

Floppy disk drive

You will need a screwdriver with a #1 Phillips tip (Items 1 and 2).

1. Locate the modules to be removed, including those listed under *Additional Modules Removed* in Figure 6-3 on page 6-13.
2. Orient the waveform generator so that its top is down on the work surface and its left side is facing you.
3. Unplug the J102 floppy driver connector (ribbon interconnect cable) that connects the disk drive to the A10 Connector board.
4. Use the screwdriver with a #1 Phillips tip to remove the two screws securing the floppy disk drive with bracket to the main chassis, and lift it away from the chassis (use Figure 6-15 as a guide). When removing the disk drive main body from the bracket, remove the one screw securing the drive to the bracket, and then pull out the disk drive.
5. To install, do this procedure in reverse order. Then refer to the *Cabinet* procedure on page 6-20 to complete assembly of the waveform generator.

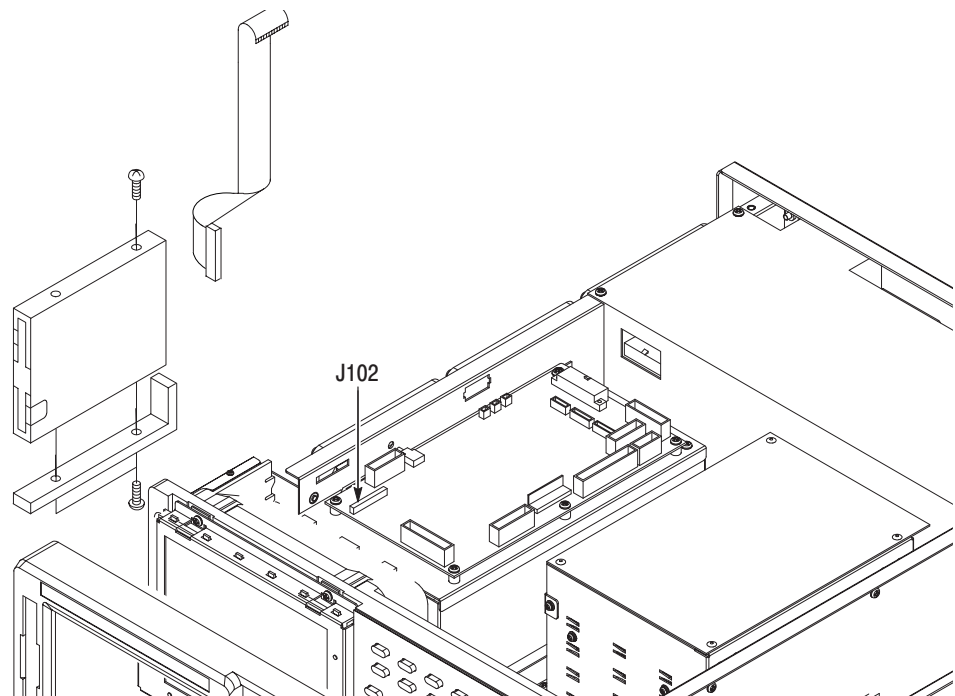

Figure 6-15: Floppy disk drive removal

Display Assembly

You will need a screwdriver with a #2 Phillips tip (Items 1 and 3).

1. Locate the modules to be removed (see Figure 6–3 on page 6–13).
2. Do the procedures *Trim Ring, Menu Button and A20 Front-Panel Assembly* immediately preceding this procedure.
3. Orient the waveform generator so that its bottom is down on the work surface and its front panel is facing you (see Figure 6–16).
4. Unplug the LCD and Back Light connectors J225 and J245 on the A10 Connector board.
5. Unplug the LCD connector in the right-hand side of the LCD display pushing toward a rear panel.
6. Remove the four screws on top and bottom of the display frame that mount the display assembly to the chassis.
7. Remove the display frame, filter, and filter retainer.
8. Remove the LCD display and bracket pulling out from left-hand side.

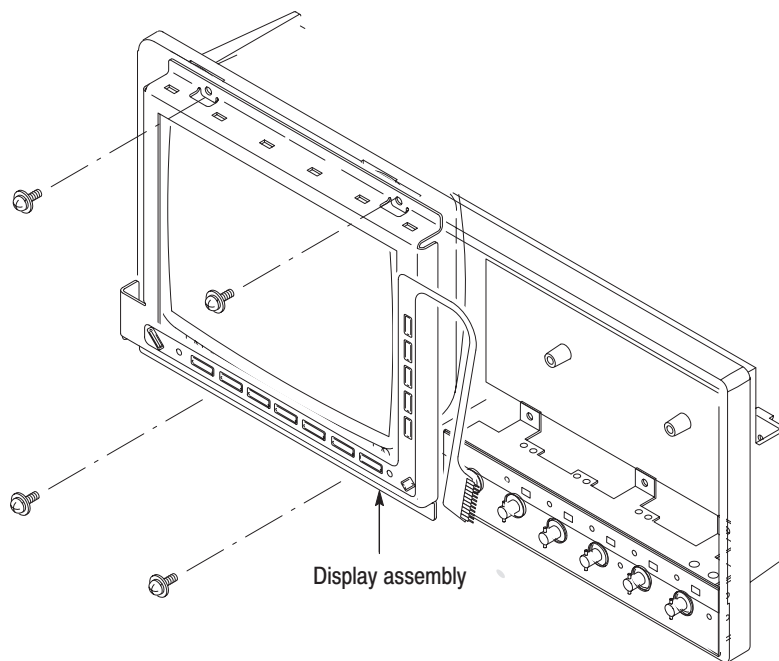

Figure 6–16: Display assembly removal

9. To install, do this procedure in reverse order.

10. See the following procedures, in the order shown, to complete reassembly of the waveform generator:
 - *A20 Front-Panel Assembly* (page 6–24)
 - *Time Ring, Menu Buttons* (page 6–23)
 - *Cabinet* (page 6–20)

PS100 Low Voltage Power Supply

You will need a screwdriver with a #2 Phillips tip (Items 1 and 3).

1. Locate the Power Supply (see Figure 6–3 on page 6–13).
2. Orient the waveform generator so that its bottom is down on the work surface and its right side is facing you.
3. To remove the low-voltage power supply, unplug four power cables from J3 on the A10 Connector board and J1, J2 and, J4 on the A50 Sequence board. See Figure 6–17.
4. Remove the two screws on the left-hand side of the rear Principal Power switch and the power cable connector that mount the low-voltage power supply to the rear chassis.
5. Remove the four screws from the top of the supply, the five screws at the bottom, and the one screw from the side that mount the supply to the main chassis. Then remove the screw securing the ground lead to the main chassis.
6. Lift the module up out of the generator to complete removal.
7. To install, do this procedure in reverse order, and then refer to the *Cabinet* procedure on page 6–20 to complete assembly of the generator.

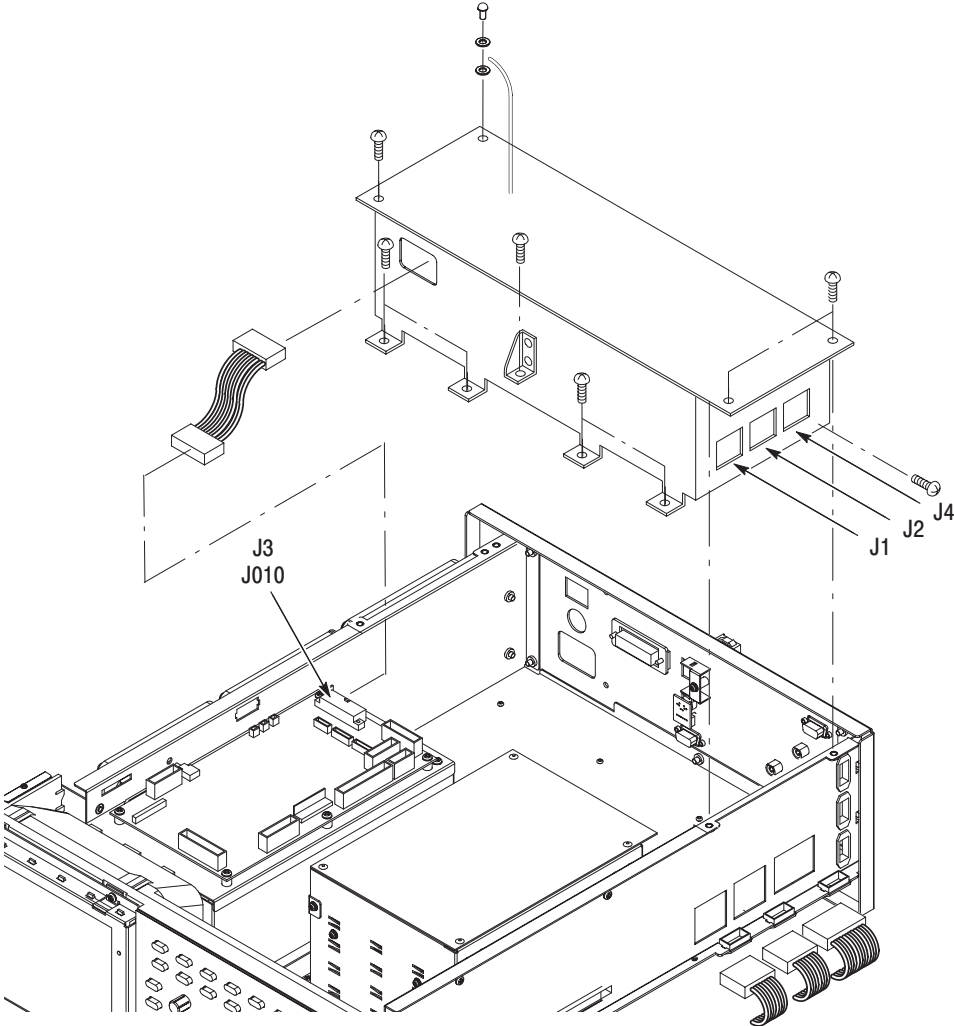

Figure 6-17: Power supply module removal

A10 Connector Board

You will need a screwdriver with a #2 Phillips tip (Items 1 and 3).

1. Locate the modules to be removed (see Figure 6–3 on page 6–13).
2. Orient the waveform generator so that its bottom is down on the work surface and its front is facing you.
3. To disconnect the *A10 Connector Board*, disconnect the following cables and connectors. See Figure 6–18 as a guide.
 - The fan's power cable at J310.
 - The cable from the low-voltage power supply at J010.
 - The cable to the PCI Backplane power supply at J320.
 - J245 LCD Backlight, J225 TFT LCD and J102 Floppy disk driver connector.
 - The interconnect cables from CPU board at J100 (CPU FDD), J110 (CPU MISC), J150 (CPU VGA & COM1) and J220 (CPU LCD).
 - The interconnect cables to the Monitor Out at J152 and the A90 Key board at J112.
 - The interconnect cable from the PCI Interface at 200.
 - The cables from the A20 Front Panel board at J154.
4. Use a screwdriver with a #2 Phillips tip to remove the five screws that attach the A11 Connector board to the HDD bracket.
5. Lift the board up and away from the HDD bracket to complete the removal.
6. To install, do this procedure in reverse order, and then refer to the *Cabinet* procedure on page 6–20 to complete assembly of the generator.

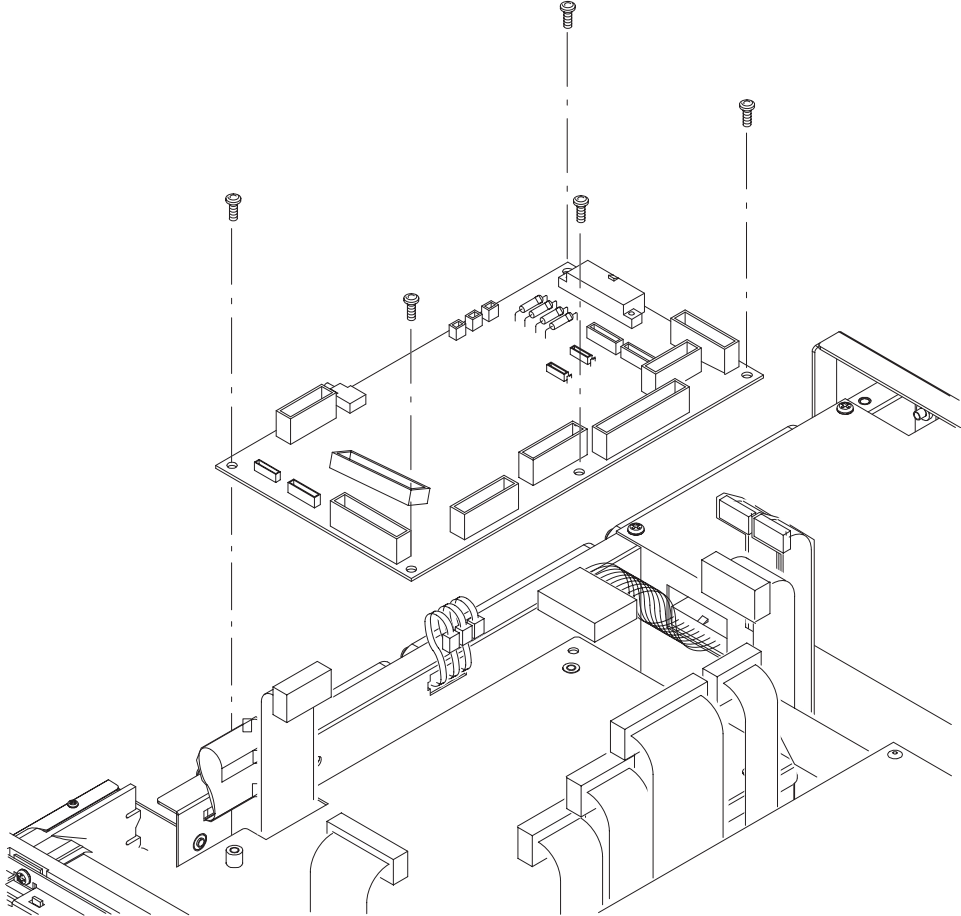

Figure 6-18: A10 Connector board removal

CPU unit This procedure describes how to remove these circuit boards contained in the CPU unit:

- CPU Board
- Hard disk and Flash disk
- A40 PCI Interface Board
- GPIB Board
- Back Plane

NOTE. *The Lithium polycarbon monofluoride battery on the CPU board is not user-replaceable. Removing the battery erases calendar backup data. Replace the CPU board as a unit.*

You will need a screwdriver with a #2 Phillips tip (Items 1 and 3).

1. Locate the modules to be removed (see Figure 6–4 on page 6–14).
2. Orient the waveform generator so that its bottom is down on the work surface and the right side facing you.
3. Remove the CPU unit using Figure 6–19 as a guide while doing the following substeps.
 - a. Unplug the GPIB interconnect cable at the GPIB board. Unplug the LAN interconnect cable and the VGA and COM1 interconnect cable at the CPU board.
 - b. Unplug the LCD flat cable, the FDD flat cable, the HDD IDE flat cable, and the MISC flat cable at the CPU board.
 - c. Unplug two flat cables from the A50 Sequence board and the flat cable from the A10 Connector board at the A40 PCI Interface board.
 - d. Remove the two screws on the bottom and another two from the right side.
 - e. Lift the CPU Unit up away from the main chassis.

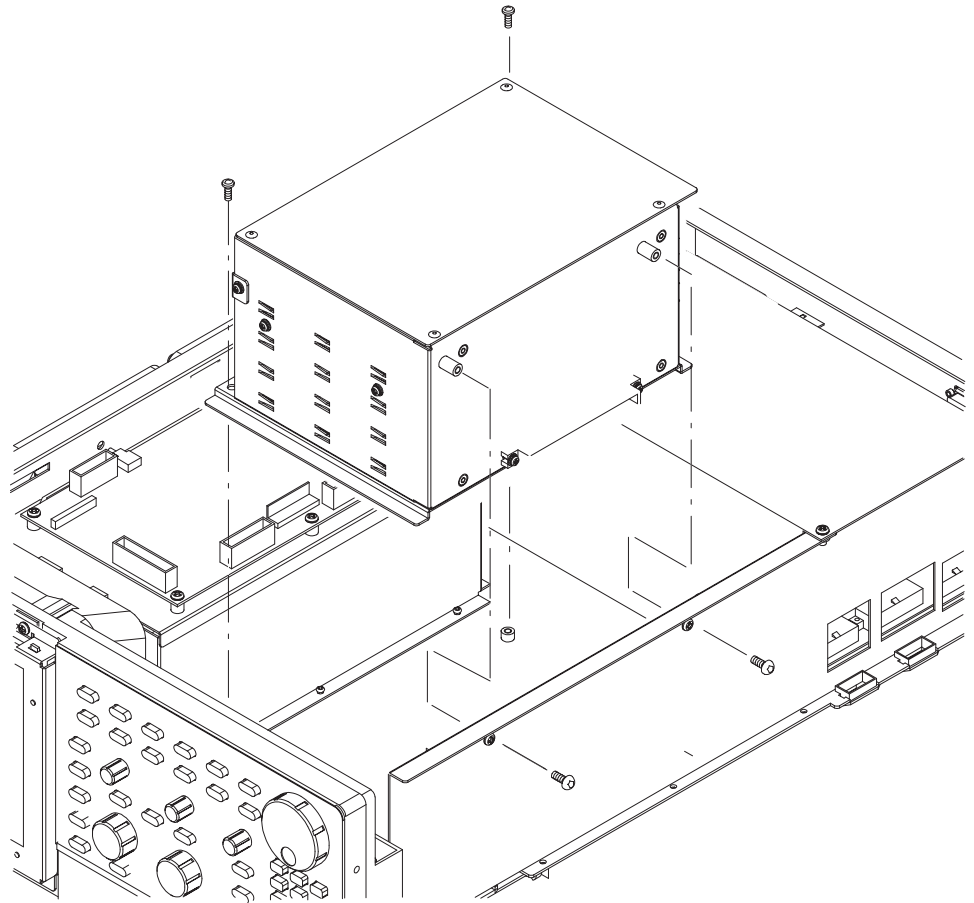

Figure 6-19: CPU unit removal

4. Remove the CPU Board using Figure 6-20 as a guide while doing the following substeps:
 - a. Using a screwdriver with a #2 Phillips tip, remove the screw securing the CPU board to the frame with a retainer on the the right side of the unit.
 - b. Remove the screw on the left side of the CPU board.
 - c. Grasp the board and slide it out of the unit.

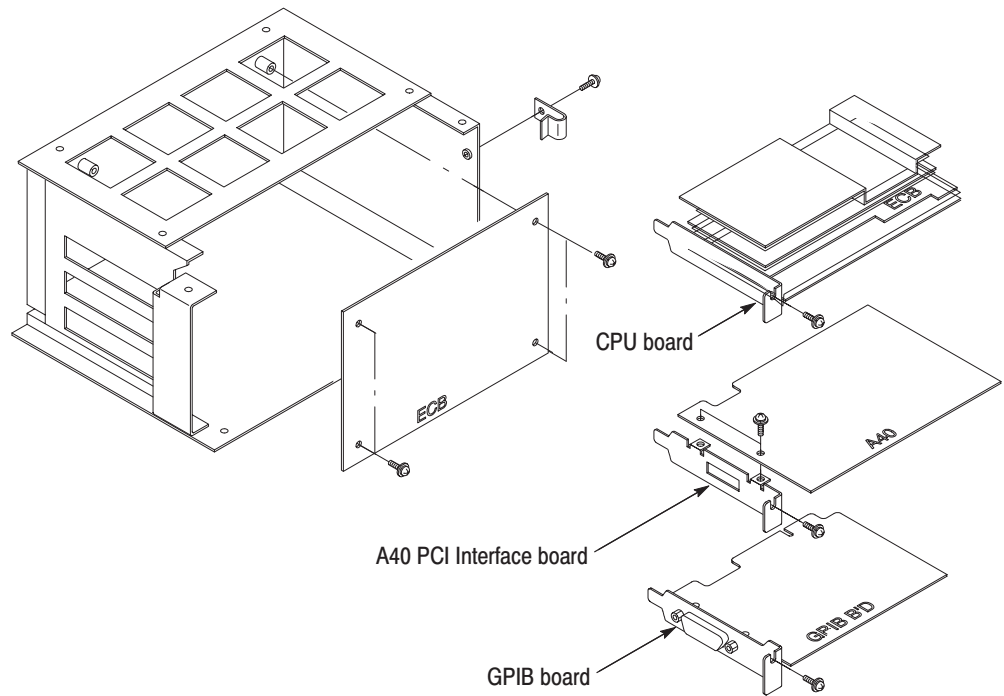

Figure 6-20: CPU, A40 PCI Interface, and GPIB boards removal

5. Remove the A40 PCI Interface Board using a screwdriver with a #2 Phillips tip to remove the screw on the left side of the A40 PCI Interface Board. See Figure 6-20.
6. Grasp the board, and slide it out.
7. Remove the GPIB board using a screwdriver with a #2 Phillips tip to remove the screw on the left side of the GPIB board. See Figure 6-20.
8. Grasp the board, and slide it out.
9. Remove the Back Plane by using a screwdriver with a #2 Phillips tip to remove the four screws securing the board to the frame. See Figure 6-20.
10. Grasp the board, and slide it out.
11. To install, do this procedure in reverse order.
12. Refer to the following procedures, in the order shown, to complete assembly of the waveform generator.
 - *Cabinet* (page 6-20)

Hard disk and flash disk

This procedure describes how to remove the Hard disk and Flash disk unit.

You will need a screwdriver with a Phillips #2 tip (Items 1 and 3).

1. Locate the modules to be removed (see Figure 6-4 on page 6-14).
2. Orient the waveform generator so that its bottom is down on the work surface and its front is facing you.
3. The hard disk unit is under the A10 board. Do the procedure *A10 Connector Board* on page 6-36.
4. Unplug the IDE interface cable from the IDE interface connector on the disk drive.
5. Using a screwdriver with a Phillips #2 tip, remove the four screws securing the hard disk and flash disk bracket to the chassis. See Figure 6-21.
6. Remove the four screws that secure the hard disk drive and the flash disk drive to the bracket.

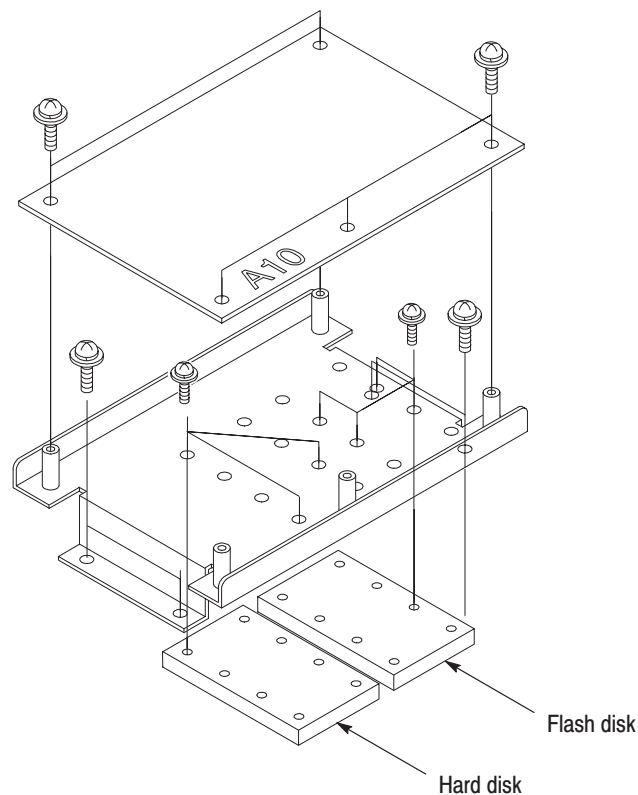

Figure 6-21: Hard disk and flash disk removal

Rear Chassis

You need a screwdriver with a #2 Phillips tip (Items 1 and 3).

1. Locate the modules to be removed (see Figure 6–3 on page 6–13).
2. Do the procedure *PS100 Low Voltage Power Supply* (see page 6–34) to remove the power supply module.
3. Install the front cover (optional accessory) if it's not already installed.
4. Orient the waveform generator so that its bottom is down on the work surface and its rear is facing you.
5. Remove the rear chassis using Figure 6–22 as a guide when doing the following substeps:
 - a. Unplug these cables:
 - The GPIB interconnect cable at GPIB card in the CPU Unit.
 - The LAN interconnect cable and the Option port interconnect cable at the connector on the CPU board.
 - The cable to the DISPLAY MONITOR OUT at J152 and the KEYBOARD at J112 on the A10 Connector board.
 - The Event In cable at J1000 on the A5 Sequence board.
 - The Clock In at J210, Clock Out at J700, 10size MHz Ref In at J500, 10MHz Ref Out at J530, and Trig In at J300 coaxial cables on the A50 Sequence board.
 - The CHx Add In at the J300 coaxial cable on the A70/A72 Output board.
 - The CHx Marker1 at J1004 and Marker2 at the J1006 coaxial cables on the A52 AWG board.
 - b. Remove the 5 screws securing the rear chassis to the main chassis.

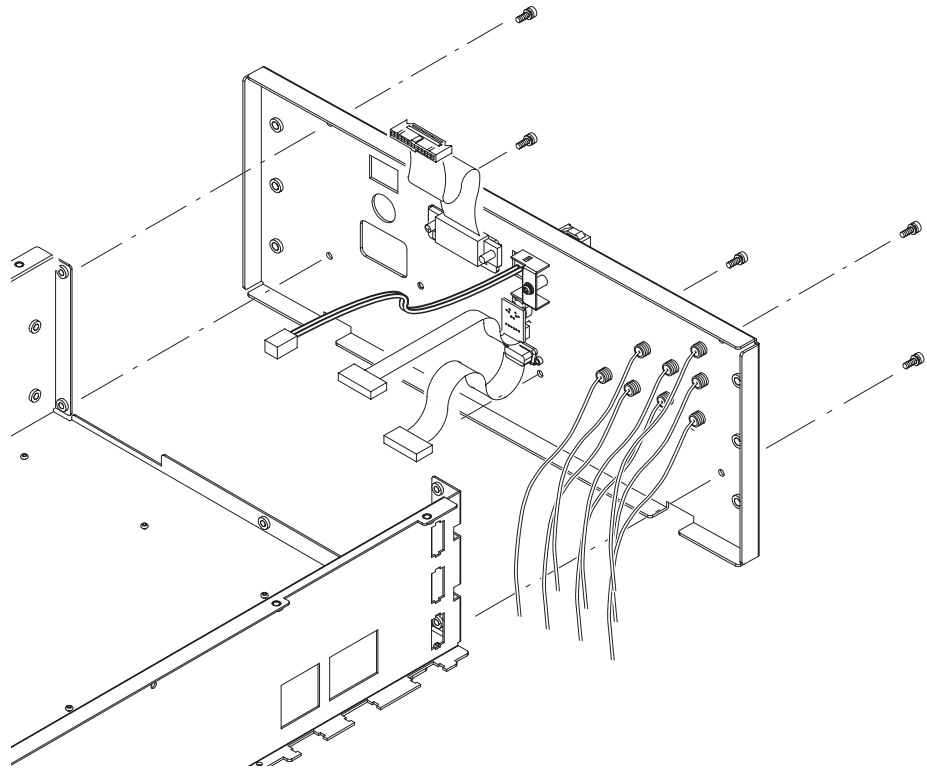

Figure 6-22: Rear Chassis removal

6. To install, do this procedure in reverse order, and then see the following procedures, in the order listed to complete the assembly.
 - *PS100 Low Voltage Power Supply* (page 6-34)
 - *Cabinet* (page 6-20)

Procedures for Internal Modules (2)

You should have completed the *Access Procedure* on page 6–16 before doing any of the procedures for the Internal modules(2). The procedures are presented in the following order:

- *A80 Digitalout Board*
- *A60 Memory Board*
- *A70/A72 Output Board*
- *A50 Sequence Board*
- *A52 AWG Board*

A80 Digital Out Board (Option03 only)

You will need a screwdriver with a #2 Phillips tip (Items 1 and 3).

1. Locate the modules to be removed (see Figure 6–5 on page 6–15).
2. Orient the waveform generator so that its top is down on the work surface and its rear is facing you.
3. Remove the *A80 Digital out Board* using Figure 6–23 on page 6–45 as a guide.
 - a. Remove the three screws attaching the Digital out board to the *A70/A72 Output Board*.
4. Lift the Digital Out board up perpendicularly from the *A70/A72 Output Board* to complete the removal.

NOTE. *A80 Digital Oout Board has a connector on its left-hand side, and is connected to the A70/A72 Output Board.*

If you remove A80 Digital Out Board, raise the bord perpendicularly. If the post spacer(s) is removed with the Output board, remove the spacer(s) and screw it back into its mounting hole.

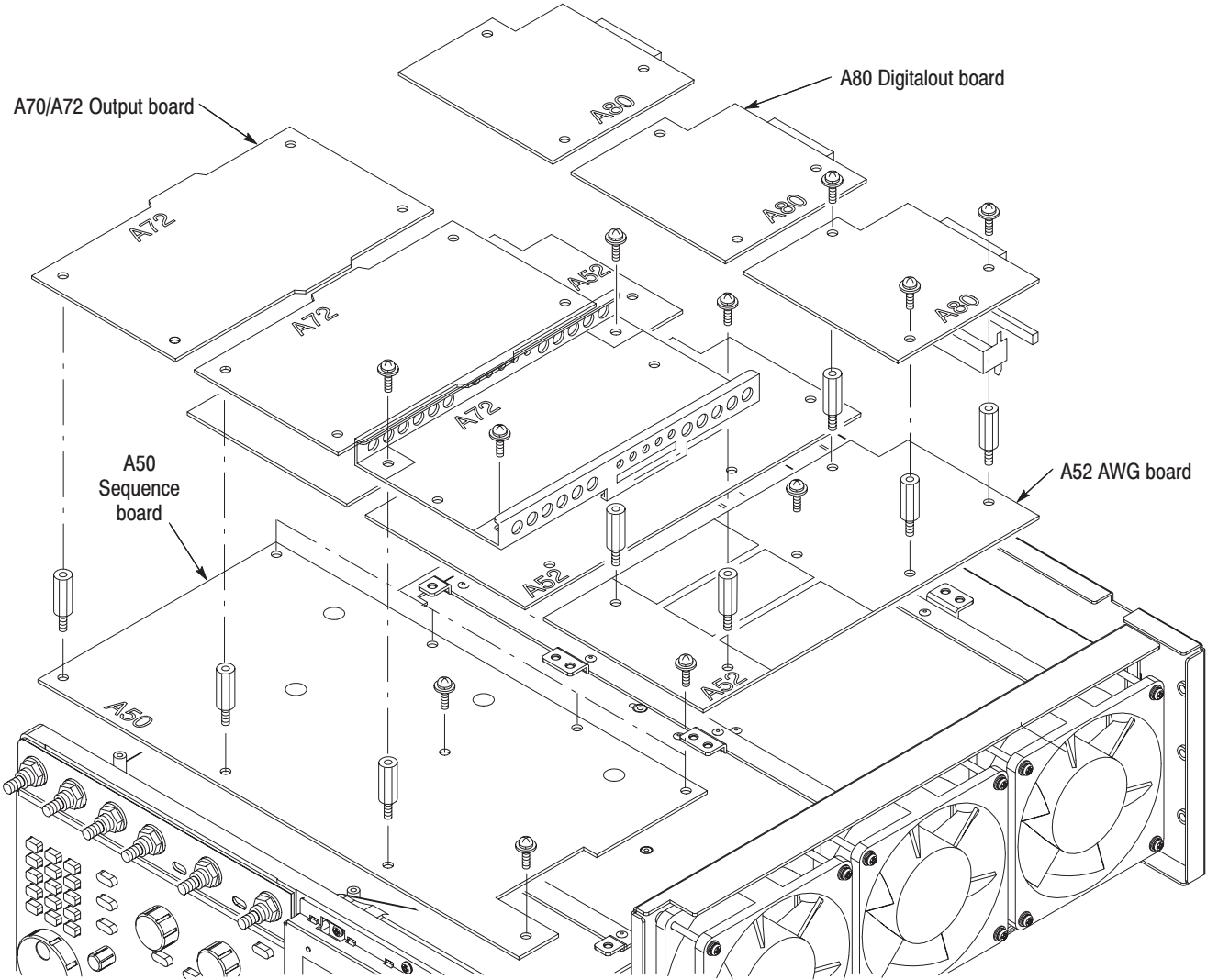

Figure 6-23: A80, A70/A72, A52, A50 Boards removal

5. To install, do the procedure in reverse order.

A60 Memory Board

You will need an angled-tip tweezers (Item 10).

1. Locate the modules to be removed (see Figure 6–5 on page 6–15).
2. Orient the waveform generator so that its top is down on the work surface and its right side is facing you.
3. To remove the *A60 Memory board*,. release the retainer latches securing the memory boards to the *A52 AWG Board*. See Figure 6–24. Using the tweezers, pinch the tab of the retainer out of the hole of the memory board. Then, insert the tip of the tweezers into the hole of the retainer to slide it out, and lift out the memory board.
4. Repeat step 3 to remove the other memory boards.

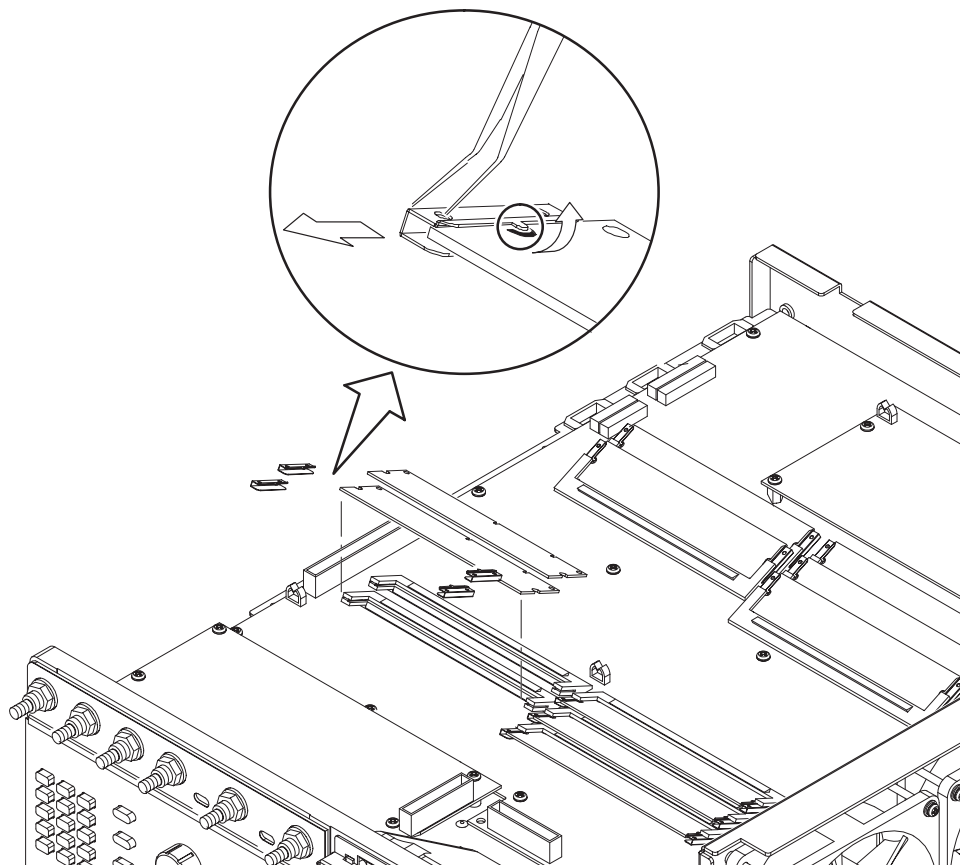

Figure 6–24: A60 Memory board removal

5. To install each memory board, reverse step 3.

A70/A72 Output Board

You will need a screwdriver with a #2 Phillips tip (Items 1 and 3).

1. Locate the modules to be removed (see Figure 6–5 on page 6–15).
2. Do the procedure that precedes this procedure to remove the interconnect cables.
3. Orient the waveform generator so that its top is down on the work surface and its front is facing you.
4. Remove *A70/A72 Output Board* using Figure 6–23 on page 6–45 as a guide.
5. Unplug the following cables and connector:
 - The coaxial cables to CHx Output connector at J190, and J290 (A72 only).
 - The coaxial cables from ADD INPUT at J300.
 - The interconnect cables from the *A52 AWG Board* at J100 and J200.
6. Remove the four screws attaching the Output board to the main chassis and *A52 AWG Board*.
7. Lift the Output board up perpendicularly from the main chassis and *A52 AWG Board* to complete the removal.

NOTE. *A70/A72 Output Board* has a connector in a frontpanel-hand side, and is connected with *A50 Sequence Board*.

If you remove A80 Digital Out Board, raise the board perpendicularly. If the post spacer(s) is removed with the Output board, remove the spacer(s) and screw it back into its mounting hole.

8. To install, do this procedure in reverse order, and then refer to the procedure *Cabinet* (page 6–20) to complete the assembly.

A52 AWG Board

You will need a screwdriver with a #2 Phillips tip (Items 1 and 3) and a nutdriver (Item 7).

1. Locate the modules to be removed (see Figure 6–5 on page 6–15).
2. Do the procedure *A70/A72 Output Board* and *A80 Digitalout Board* (Op 03 only) that precedes this procedure to remove the AWG board.
3. Orient the waveform generator so that its top is down on the work surface and its rear is facing you.
4. Remove the *A52 AWG Board*, using Figure 6–23 on page 6–45 as a guide.
5. Unplug the following cables and connectors:
 - Two connectors, J1004 and J1006, to the MARKER OUT1 and 2 of the rear panel.
6. Remove the five spacer posts and one screw securing the AWG board to the main chassis.
7. Lift the AWG board up perpendicularly from the main chassis to complete the removal.
8. To install, do this procedure in reverse order, and then refer to the following procedures, in the order listed, to complete the assembly.
 - *A70/A72 Output Board*
 - *A80 Digitalout Board* (Option 03 only)
 - *Cabinet* (page 6–20).

NOTE. *A52 AWG Board has a connector in a frontpanel-hand side, and is connected with A50 Sequence Board.*

If you remove A80 Digital Out Board, raise the board perpendicularly. If the post spacer(s) is removed with the Output board, remove the spacer(s) and screw it back into its mounting hole.

A50 Sequence Board

You will need a screwdriver with a #2 Phillips tip (Items 1 and 3) and a 5 mm nutdriver (Item 7).

1. Locate the modules to be removed (see Figure 6–5 on page 6–15).
2. Do the procedure *A70/A72 Output Board*, *A80 Digital Out Board* (Op 03 only) and *A52 AWG Board* that precedes this procedure to remove the Sequence board.
3. Orient the waveform generator so that its top is down on the work surface and its rear is facing you.
4. Unplug the following cables and connectors:
 - Three power supply cables at J0201, J0202 and J0204.
 - The cable from Event Input at J1000.
 - The flatcable from A22 On/Off board at J200.
 - Two flatcables from PCI Interface board at J100 and J110.
 - The coaxial cables from 10MHz Ref Out at J530, 10MHz Ref In at J500, Clock Out at J700, Clock In at J210, and Trigger In at J300.
5. Remove the *A50 Sequence Board* using Figure 6–23 on page 6–45 as a guide.
 - a. Remove the three spacer posts and five screws attaching the Sequencer board to the main chassis.
6. To install, do the procedure in reverse order.

Troubleshooting

This subsection contains information and procedures designed to help you isolate faulty modules in the waveform generator. If a module needs to be replaced, follow the *Removal and Installation Procedures* located in this section.

This subsection consists of the following flowcharts:

- Figure 6–25: Primary Troubleshooting Procedure
- Figure 6–26: Troubleshooting Procedure 1 — Power Supply Module
- Figure 6–28: Troubleshooting Procedure 2 — CPU or Front-panel Module
- Figure 6–29: Troubleshooting Procedure 3 — LCD and backlight
- Figure 6–31: Troubleshooting Procedure 4 — Module Isolation

Diagnostics

The waveform generator has two levels of internal diagnostics that focus on verifying, adjusting, and isolating faulty modules.

Both levels of internal diagnostics report any bad modules and/or interfaces. If a bad module and/or interface is found, use the troubleshooting procedures in this section to determine which module needs to be replaced.

The two levels of diagnostics are the short confidence set and the extended set that tests the oscilloscope circuitry in depth and takes more time. At power on, the waveform generator automatically executes the short set. The extended set is optional and is executed by using the following procedure:

Prerequisites: Power on the waveform generator and allow a 20 minute warm-up before doing this procedure.

1. *Display the diagnostics menu:* Press **UTILITY** → **Diag**.
2. *Select the menu:* Select **ALL** using the general purpose knob.
3. *Run the diagnostics:* Press **Execute Diagnostic**.
4. *Wait:* The internal diagnostics do an exhaustive verification of proper function. This verification will take several minutes. When finished, the waveform generator will display a report of any bad modules and/or interfaces.



For power supply connectors, see Figure 6–27.

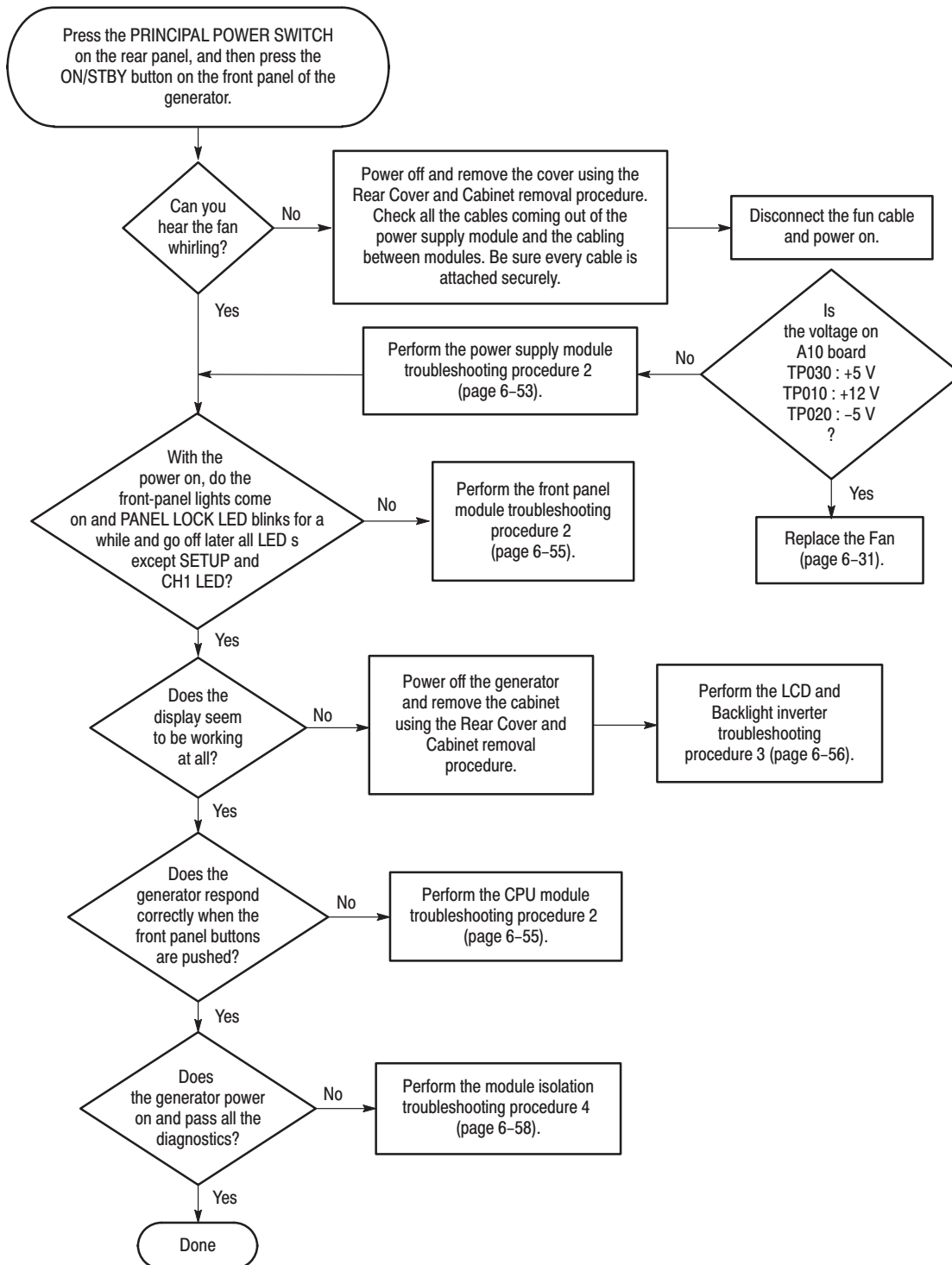

Figure 6-25: Primary troubleshooting procedure

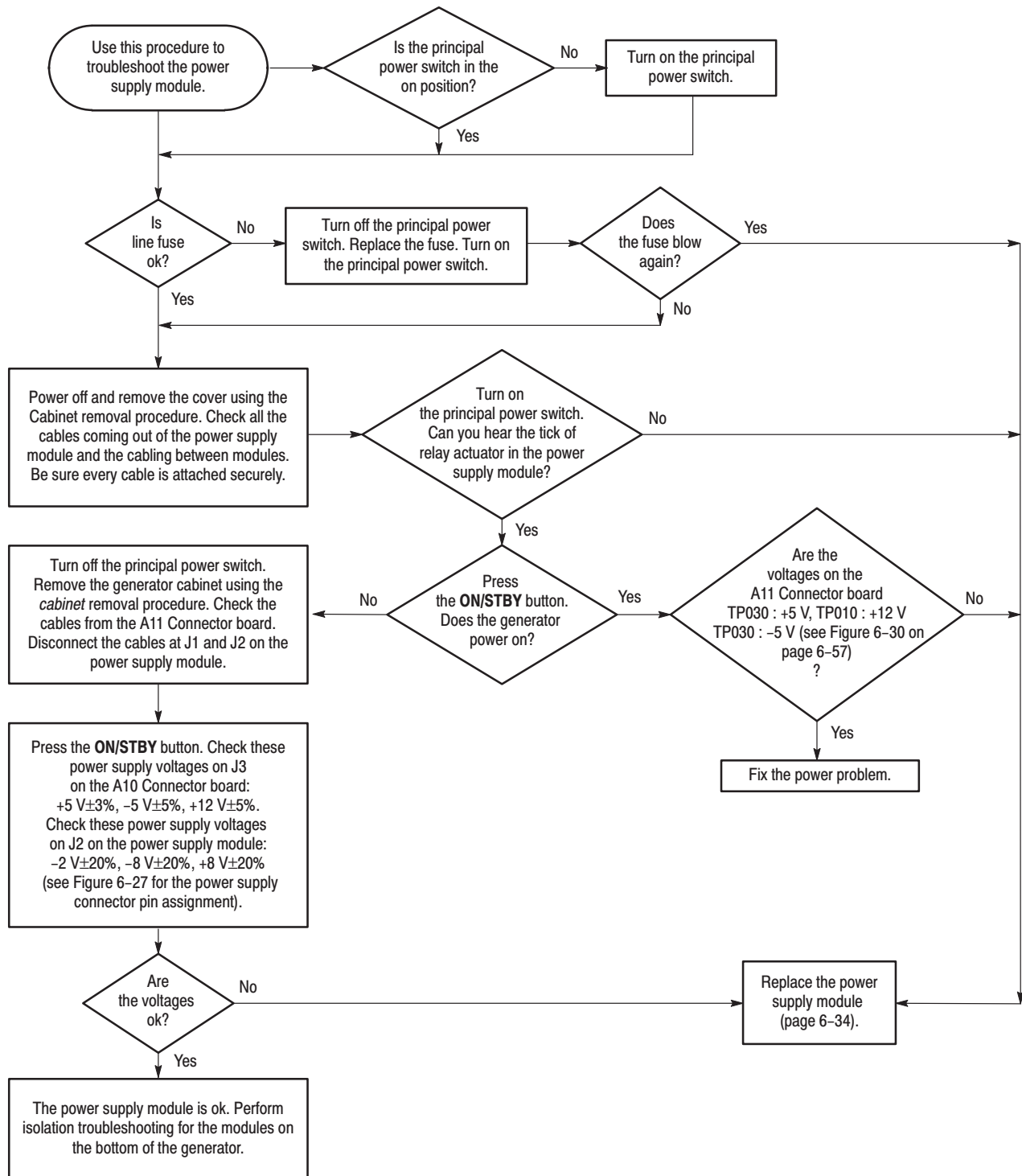

Figure 6-26: Troubleshooting procedure 1 — Power Supply module

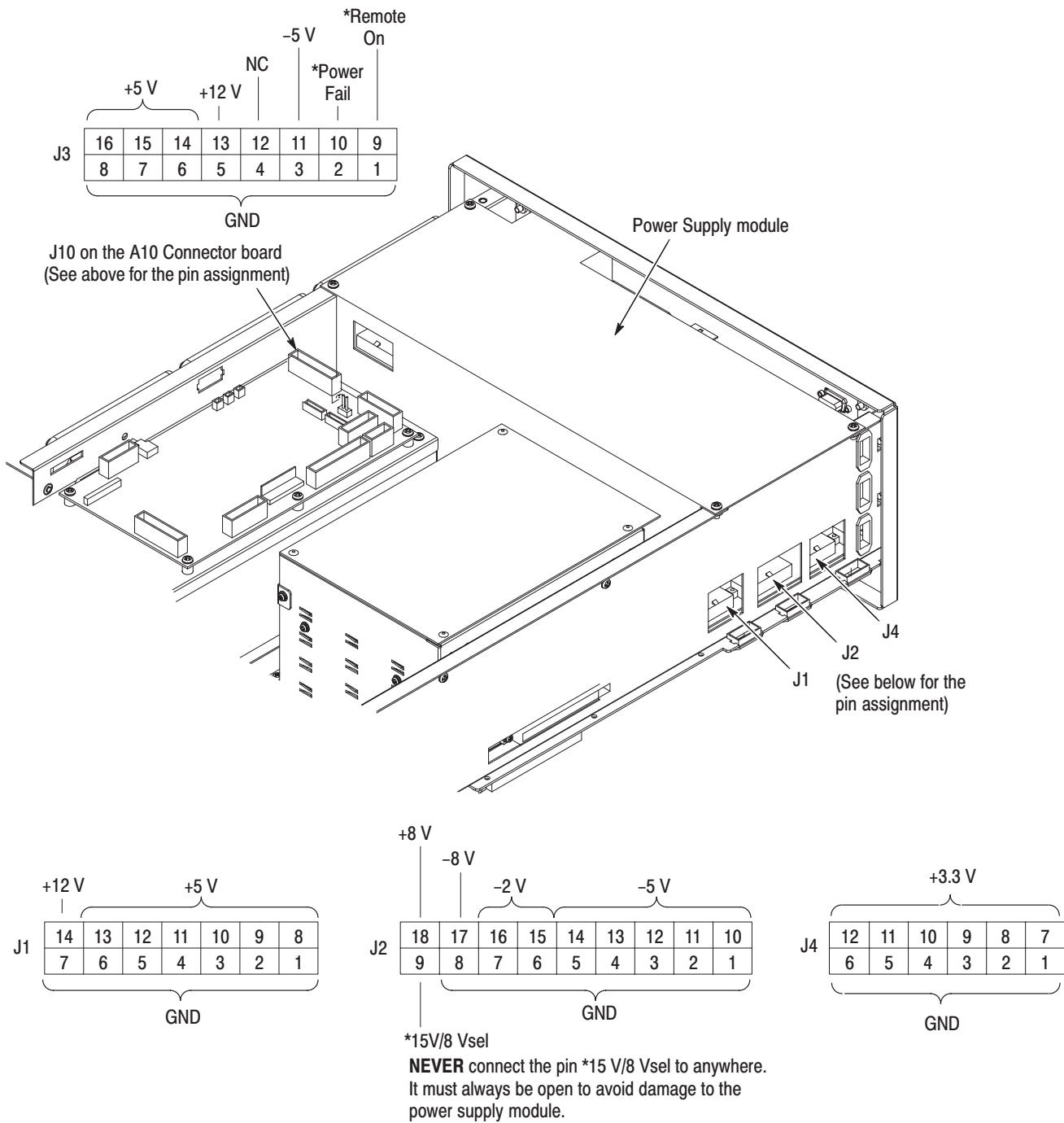

Figure 6-27: Power Supply connectors

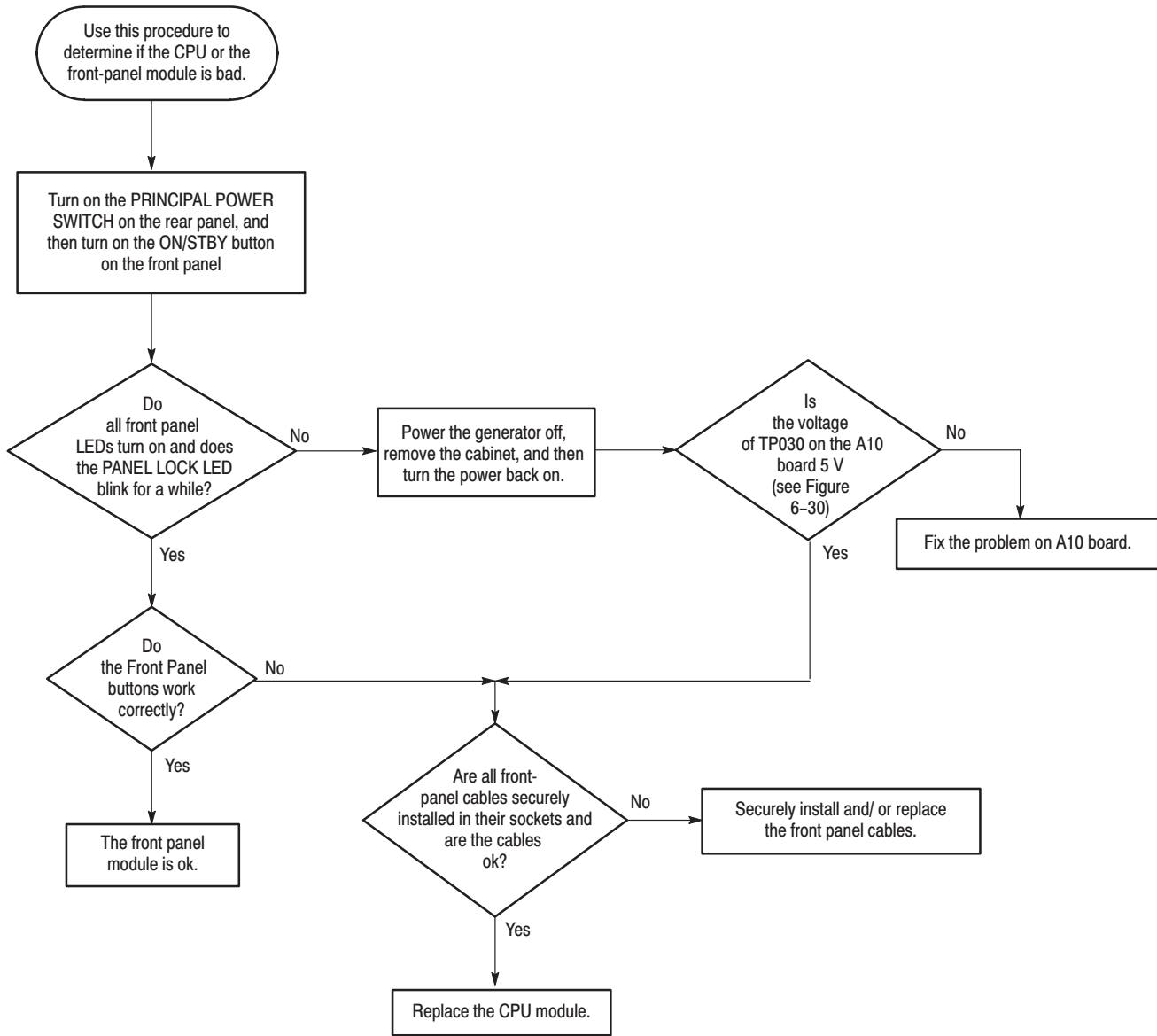

Figure 6-28: Troubleshooting procedure 2 — CPU or Front Panel module

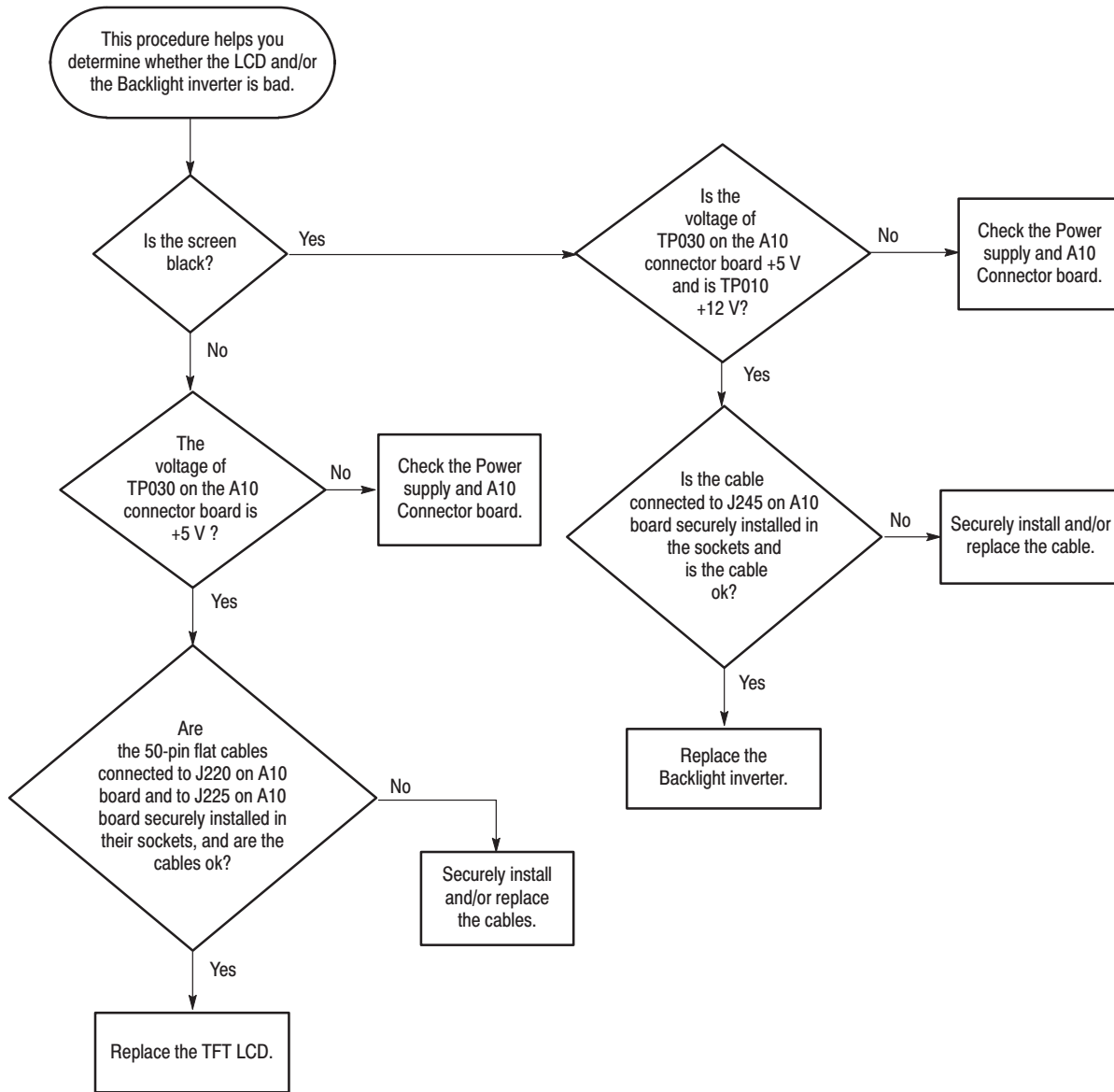

Figure 6-29: Troubleshooting procedure 3 — LCD module

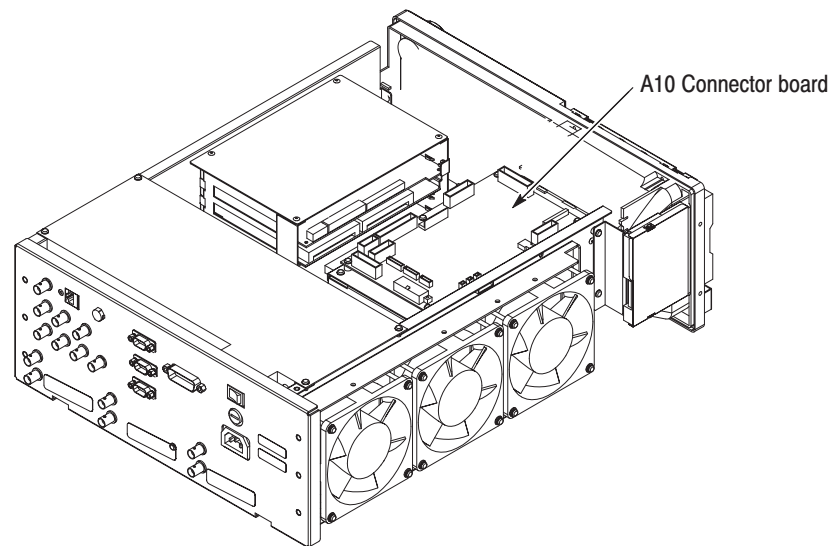
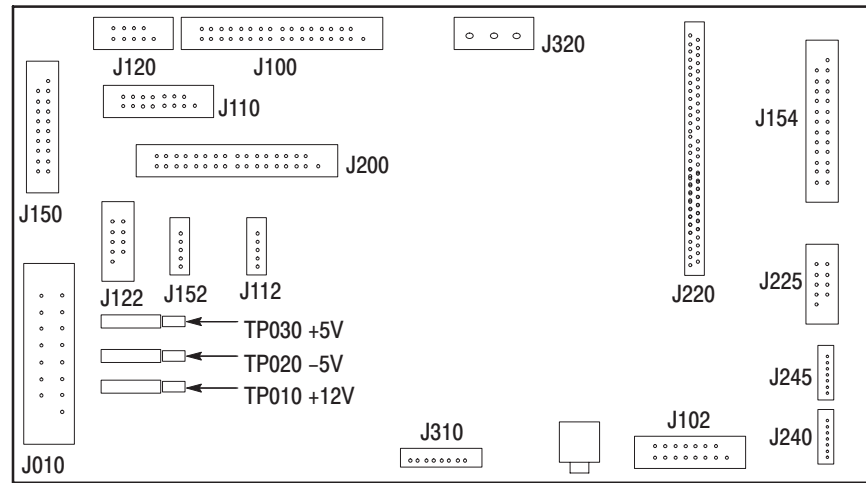

Figure 6-30: A10 Connector board

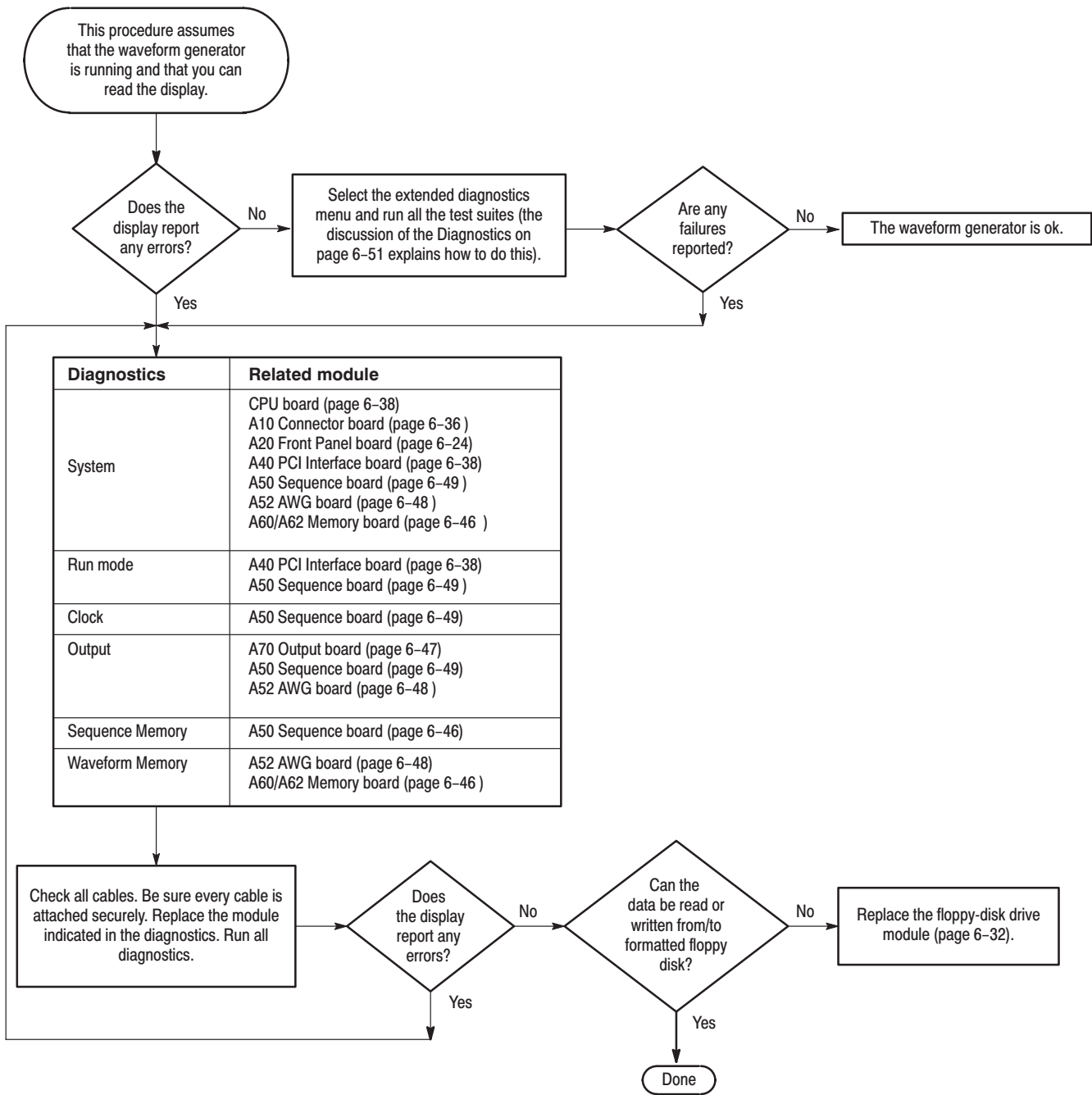

Figure 6-31: Troubleshooting procedure 4 — Module isolation

Messages and Codes

Error and event codes with negative values are SCPI standard codes. Error and event codes with positive values are unique to the waveform generator series number.

Table 6–5 lists event code definitions. When an error occurs, you can find its error class by checking for its the code range in Tables 6–6 through 6–14. Events in these tables are organized by event class.

Table 6–5: Definition of event codes

| Event class | Code range | Description |
|---------------------------------|-------------------|--------------------------------|
| No error | 0 | No event or status |
| Command errors | –100 to –199 | Command syntax errors |
| Execution errors | –200 to –299 | Command execution errors |
| Device-specific errors | –300 to –399 | Internal device errors |
| Query errors | –400 to –499 | System event and query errors |
| Power-on events | –500 to –599 | Power-on events |
| User request events | –600 to –699 | User request events |
| Request control events | –700 to –799 | Request control events |
| Operation complete events | –800 to –899 | Operation complete events |
| Extended device-specific errors | 1 to 32767 | Device dependent device errors |
| Reserved | other than above | not used |

Command Errors

Command errors are returned when there is a syntax error in the command.

Table 6-6: Command errors

| Error code | Error message |
|-------------------|---------------------------------|
| -100 | Command error |
| -101 | Invalid character |
| -102 | Syntax error |
| -103 | Invalid separator |
| -104 | Data type error |
| -105 | GET not allowed |
| -108 | Parameter not allowed |
| -109 | Missing parameter |
| -110 | Command header error |
| -111 | Header separator error |
| -112 | Program mnemonic too long |
| -113 | Undefined header |
| -114 | Header suffix out of range |
| -115 | Unexpected number of parameters |
| -120 | Numeric data error |
| -121 | Invalid character in number |
| -123 | Exponent too large |
| -124 | Too many digits |
| -128 | Numeric data not allowed |

Table 6-6: Command errors (Cont.)

| Error code | Error message |
|-------------------|----------------------------------|
| -130 | Suffix error |
| -131 | Invalid suffix |
| -134 | Suffix too long |
| -138 | Suffix not allowed |
| -140 | Character data error |
| -141 | Invalid character data |
| -144 | Character data too long |
| -148 | Character data not allowed |
| -150 | String data error |
| -151 | Invalid string data |
| -158 | String data not allowed |
| -160 | Block data error |
| -161 | Invalid block data |
| -168 | Block data not allowed |
| -170 | Expression error |
| -171 | Invalid expression |
| -178 | Expression data not allowed |
| -180 | Macro error |
| -181 | Invalid outside macro definition |
| -183 | Invalid inside macro definition |
| -184 | Macro parameter error |

Execution Errors

These error codes are returned when an error is detected during command execution.

Table 6-7: Execution errors

| Error code | Error message |
|-------------------|--------------------------|
| -200 | Execution error |
| -201 | Invalid while in local |
| -202 | Settings lost due to RTL |
| -203 | Command protected |
| -210 | Trigger error |
| -211 | Trigger ignored |
| -212 | Arm ignored |
| -213 | Init ignored |
| -214 | Trigger deadlock |
| -215 | Arm deadlock |
| -220 | Parameter error |
| -221 | Settings conflict |
| -222 | Data out of range |
| -223 | Too much data |
| -224 | Illegal parameter value |
| -225 | Out of memory |
| -226 | Lists not same length |
| -230 | Data corrupt or stale |
| -231 | Data questionable |
| -232 | Invalid format |
| -233 | Invalid version |
| -240 | Hardware error |
| -241 | Hardware missing |
| -250 | Mass storage error |
| -251 | Missing mass storage |
| -252 | Missing media |

Table 6-7: Execution errors (Cont.)

| Error code | Error message |
|-------------------|--------------------------------|
| -253 | Corrupt media |
| -254 | Media full |
| -255 | Directory full |
| -256 | File name not found |
| -257 | File name error |
| -258 | Media protected |
| -260 | Expression error |
| -261 | Math error in expression |
| -270 | Macro error |
| -271 | Macro syntax error |
| -272 | Macro execution error |
| -273 | Illegal macro label |
| -274 | Macro parameter error |
| -275 | Macro definition too long |
| -276 | Macro recursion error |
| -277 | Macro rejuvenation not allowed |
| -278 | Macro header not found |
| -280 | Program error |
| -281 | Cannot create program |
| -282 | Illegal program name |
| -283 | Illegal variable name |
| -284 | Program currently running |
| -285 | Program syntax error |
| -286 | Program runtime error |
| -290 | Memory use error |
| -291 | Out of memory |
| -292 | Referenced name does not exist |
| -293 | Referenced name already exists |
| -294 | Incompatible type |

Device Specific Errors

These error codes are returned when an internal instrument error is detected. This type of error can indicate a hardware problem.

Table 6-8: Device specific errors

| Error code | Error message |
|-------------------|----------------------------------|
| -300 | Device specific error |
| -310 | System error |
| -311 | Memory error |
| -312 | PUD memory lost |
| -313 | Calibration memory lost |
| -314 | Save/recall memory lost |
| -315 | Configuration memory lost |
| -320 | Storage fault |
| -321 | Out of memory |
| -330 | Self-test failed |
| -340 | Calibration failed |
| -350 | Queue overflow |
| -360 | Communication error |
| -361 | Parity error in program message |
| -362 | Framing error in program message |
| -363 | Input buffer overrun |
| -365 | Time out error |

Query Errors

These error codes are returned in response to an unanswered query (see Table 6–9).

Table 6–9: Query errors

| Error code | Error message |
|------------|--|
| -400 | query error |
| -410 | query INTERRUPTED |
| -420 | query UNTERMINATED |
| -430 | query DEADLOCKED |
| -440 | query UNTERMINATED after indefinite response |

Power-On Events

These events occur when the instrument detects an off to on transition in its power supply (see Table 6–10).

Table 6–10: Power-on events

| Event code | Event message |
|------------|---------------|
| -500 | Power on |

User Request Events

These events are unused in the waveform generator (see Table 6–11).

Table 6–11: User request events

| Event code | Event message |
|------------|---------------|
| -600 | User request |

Request Control Events

This event is unused in the waveform generator (see Table 6–12).

Table 6–12: Request control events

| Event code | Event message |
|------------|-----------------|
| -700 | Request control |

Operation Complete Events

This event occurs when the instrument’s synchronization protocol, having been enabled by an *OPC command, completes all selected pending operations (see Table 6–13).

Table 6–13: Operation complete events

| Event code | Event message |
|------------|--------------------|
| -800 | Operation complete |

Device Errors

Table 6–14 lists AWG400 series error code and their meaning.

Table 6–14: Messages and Codes

| Error code | Error message | Related module | Supplementary Information |
|-----------------------------|--|----------------|-------------------------------|
| /* ---- Calibration ---- */ | | | |
| 1101 | CH1 internal offset calibration failure | A72/70(Output) | Check A72/A70 and connection. |
| 1102 | CH2 internal offset calibration failure | A72/70(Output) | Check A72/A70 and connection. |
| 1103 | CH3 internal offset calibration failure | A72/70(Output) | Check A72/A70 and connection. |
| 1104 | $\overline{\text{CH1}}$ internal offset calibration failure | A70(Output) | Check A70 and connection. |
| 1105 | $\overline{\text{CH2}}$ internal offset calibration failure | A70(Output) | Check A70 and connection. |
| 1106 | $\overline{\text{CH3}}$ internal offset calibration failure | A70(Output) | Check A70 and connection. |
| 1201 | CH1 output offset calibration failure | A72/70(Output) | Check A72/A70 and connection. |
| 1202 | CH2 output offset calibration failure | A72/70(Output) | Check A72/A70 and connection. |
| 1203 | CH3 output offset calibration failure | A72/70(Output) | Check A72/A70 and connection. |
| 1204 | $\overline{\text{CH1}}$ output offset calibration failure | A70(Output) | Check A70 and connection. |
| 1205 | $\overline{\text{CH2}}$ output offset calibration failure | A70(Output) | Check A70 and connection. |
| 1206 | $\overline{\text{CH3}}$ output offset calibration failure | A70(Output) | Check A70 and connection. |
| 1301 | CH1 Gain calibration failure | A72/70(Output) | Check A72/A70 and connection. |
| 1302 | CH2 Gain calibration failure | A72/70(Output) | Check A72/A70 and connection. |
| 1303 | CH3 Gain calibration failure | A72/70(Output) | Check A72/A70 and connection. |
| 1304 | $\overline{\text{CH1}}$ Gain calibration failure | A70(Output) | Check A70 and connection. |
| 1305 | $\overline{\text{CH2}}$ Gain calibration failure | A70(Output) | Check A70 and connection. |
| 1306 | $\overline{\text{CH3}}$ Gain calibration failure | A70(Output) | Check A70 and connection. |
| 1401 | CH1 Gain difference calibration failure | A72/70(Output) | Check A72/A70 and connection. |
| 1402 | CH2 Gain difference calibration failure | A72/70(Output) | Check A72/A70 and connection. |
| 1403 | CH3 Gain difference calibration failure | A72/70(Output) | Check A72/A70 and connection. |
| 1404 | $\overline{\text{CH1}}$ Gain difference calibration failure | A70(Output) | Check A70 and connection. |
| 1405 | $\overline{\text{CH2}}$ Gain difference calibration failure | A70(Output) | Check A70 and connection. |
| 1406 | $\overline{\text{CH3}}$ Gain difference calibration failure | A70(Output) | Check A70 and connection. |
| 1501 | CH1 Direct output Gain calibration failure | A72/70(Output) | Check A72/A70 and connection. |
| 1502 | CH2 Direct output Gain calibration failure | A72/70(Output) | Check A72/A70 and connection. |
| 1503 | CH3 Direct output Gain calibration failure | A72/70(Output) | Check A72/A70 and connection. |
| 1504 | $\overline{\text{CH1}}$ Direct output Gain calibration failure | A70(Output) | Check A70 and connection. |
| 1505 | $\overline{\text{CH2}}$ Direct output Gain calibration failure | A70(Output) | Check A70 and connection. |
| 1506 | $\overline{\text{CH3}}$ Direct output Gain calibration failure | A70(Output) | Check A70 and connection. |

Table 6-14: Messages and Codes (Cont.)

| Error code | Error message | Related module | Supplementary Information |
|-------------------|--|-----------------------|----------------------------------|
| 1601 | CH1 Attenuator calibration failure | A72/70(Output) | Check A72/A70 and connection. |
| 1602 | CH2 Attenuator calibration failure | A72/70(Output) | Check A72/A70 and connection. |
| 1603 | CH3 Attenuator calibration failure | A72/70(Output) | Check A72/A70 and connection. |
| 1604 | CH1 Attenuator calibration failure | A70(Output) | Check A70 and connection. |
| 1605 | CH2 Attenuator calibration failure | A70(Output) | Check A70 and connection. |
| 1606 | CH3 Attenuator calibration failure | A70(Output) | Check A70 and connection. |
| 1611 | CH1 x5dB attenuator calibration failure | A72/70(Output) | Check A72/A70 and connection. |
| 1612 | CH2 x5dB attenuator calibration failure | A72/70(Output) | Check A72/A70 and connection. |
| 1613 | CH3 x5dB attenuator calibration failure | A72/70(Output) | Check A72/A70 and connection. |
| 1614 | CH1 x5dB attenuator calibration failure | A70(Output) | Check A70 and connection. |
| 1615 | CH2 x5dB attenuator calibration failure | A70(Output) | Check A70 and connection. |
| 1616 | CH3 x5dB attenuator calibration failure | A70(Output) | Check A70 and connection. |
| 1621 | CH1 x10dB 1 attenuator calibration failure | A72/70(Output) | Check A72/A70 and connection. |
| 1622 | CH2 x10dB 1 attenuator calibration failure | A72/70(Output) | Check A72/A70 and connection. |
| 1623 | CH3 x10dB 1 attenuator calibration failure | A72/70(Output) | Check A72/A70 and connection. |
| 1624 | CH1 x10dB 1 attenuator calibration failure | A70(Output) | Check A70 and connection. |
| 1625 | CH2 x10dB 1 attenuator calibration failure | A70(Output) | Check A70 and connection. |
| 1626 | CH3 x10dB 1 attenuator calibration failure | A70(Output) | Check A70 and connection. |
| 1631 | CH1 x10dB 2 attenuator calibration failure | A72/70(Output) | Check A72/A70 and connection. |
| 1632 | CH2 x10dB 2 attenuator calibration failure | A72/70(Output) | Check A72/A70 and connection. |
| 1633 | CH3 x10dB 2 attenuator calibration failure | A72/70(Output) | Check A72/A70 and connection. |
| 1634 | CH1 x10dB 2 attenuator calibration failure | A70(Output) | Check A70 and connection. |
| 1635 | CH2 x10dB 2 attenuator calibration failure | A70(Output) | Check A70 and connection. |
| 1636 | CH3 x10dB 2 attenuator calibration failure | A70(Output) | Check A70 and connection. |
| 1641 | CH1 x20dB attenuator calibration failure | A72/70(Output) | Check A72/A70 and connection. |
| 1642 | CH2 x20dB attenuator calibration failure | A72/70(Output) | Check A72/A70 and connection. |
| 1643 | CH3 x20dB attenuator calibration failure | A72/70(Output) | Check A72/A70 and connection. |
| 1644 | CH1 x20dB attenuator calibration failure | A70(Output) | Check A70 and connection. |
| 1645 | CH2 x20dB attenuator calibration failure | A70(Output) | Check A70 and connection. |
| 1646 | CH3 x20dB attenuator calibration failure | A70(Output) | Check A70 and connection. |
| 1701 | CH1 Filter calibration failure | A72/70(Output) | Check A72/A70 and connection. |
| 1702 | CH2 Filter calibration failure | A72/70(Output) | Check A72/A70 and connection. |
| 1703 | CH3 Filter calibration failure | A72/70(Output) | Check A72/A70 and connection. |
| 1704 | CH1 Filter calibration failure | A70(Output) | Check A70 and connection. |
| 1705 | CH2 Filter calibration failure | A70(Output) | Check A70 and connection. |

Table 6-14: Messages and Codes (Cont.)

| Error code | Error message | Related module | Supplementary Information |
|---|---|------------------------|--|
| 1706 | CH3 Filter calibration failure | A70(Output) | Check A70 and connection. |
| 1711 | CH1 1MHz Filter calibration failure | A72/70(Output) | Check A72/A70 and connection. |
| 1712 | CH2 1MHz Filter calibration failure | A72/70(Output) | Check A72/A70 and connection. |
| 1713 | CH3 1MHz Filter calibration failure | A72/70(Output) | Check A72/A70 and connection. |
| 1714 | CH1 1MHz Filter calibration failure | A70(Output) | Check A70 and connection. |
| 1715 | CH2 1MHz Filter calibration failure | A70(Output) | Check A70 and connection. |
| 1716 | CH3 1MHz Filter calibration failure | A70(Output) | Check A70 and connection. |
| 1721 | CH1 5MHz Filter calibration failure | A72/70(Output) | Check A72/A70 and connection. |
| 1722 | CH2 5MHz Filter calibration failure | A72/70(Output) | Check A72/A70 and connection. |
| 1723 | CH3 5MHz Filter calibration failure | A72/70(Output) | Check A72/A70 and connection. |
| 1724 | CH1 5MHz Filter calibration failure | A70(Output) | Check A70 and connection. |
| 1725 | CH2 5MHz Filter calibration failure | A70(Output) | Check A70 and connection. |
| 1726 | CH3 5MHz Filter calibration failure | A70(Output) | Check A70 and connection. |
| 1731 | CH1 20MHz Filter calibration failure | A72/70(Output) | Check A72/A70 and connection. |
| 1732 | CH2 20MHz Filter calibration failure | A72/70(Output) | Check A72/A70 and connection. |
| 1733 | CH3 20MHz Filter calibration failure | A72/70(Output) | Check A72/A70 and connection. |
| 1734 | CH1 20MHz Filter calibration failure | A70(Output) | Check A70 and connection. |
| 1735 | CH2 20MHz Filter calibration failure | A70(Output) | Check A70 and connection. |
| 1736 | CH3 20MHz Filter calibration failure | A70(Output) | Check A70 and connection. |
| 1741 | CH1 50MHz Filter calibration failure | A72/70(Output) | Check A72/A70 and connection. |
| 1742 | CH2 50MHz Filter calibration failure | A72/70(Output) | Check A72/A70 and connection. |
| 1743 | CH3 50MHz Filter calibration failure | A72/70(Output) | Check A72/A70 and connection. |
| 1744 | CH1 50MHz Filter calibration failure | A70(Output) | Check A70 and connection. |
| 1745 | CH2 50MHz Filter calibration failure | A70(Output) | Check A70 and connection. |
| 1746 | CH3 50MHz Filter calibration failure | A70(Output) | Check A70 and connection. |
| /* ---- System Diagnostics ---- */ | | | |
| 2100 | System failure | CPU/Flash Disk/ HDD | Check CPU/Flash Disk/HDD and connection. |
| 2101 | Real-time clock power | CPU/Flash Disk/ HDD | Check CPU/Flash Disk/HDD and connection. |
| 2102 | Configuration record and Check-sum status | CPU/Flash Disk/ HDD | Check CPU/Flash Disk/HDD and connection. |
| 2103 | Incorrect configuration | CPU/Flash Disk/ HDD | Check CPU/Flash Disk/HDD and connection. |
| 2104 | Memory size miscompare | CPU/Flash Disk/ HDD | Check CPU/Flash Disk/HDD and connection. |

Table 6-14: Messages and Codes (Cont.)

| Error code | Error message | Related module | Supplementary Information |
|---|---|-----------------------|--|
| 2105 | Fixed-disk drive initialization status | CPU/Flash Disk/HDD | Check CPU/Flash Disk/HDD and connection. |
| 2106 | Time status | CPU/Flash Disk/HDD | Check CPU/Flash Disk/HDD and connection. |
| 2110 | Front panel failure | A20(Front Panel) | Check A20 And connection. |
| 2111 | Front panel configuration | A20(Front Panel) | Check A20 and connection. |
| 2112 | Front panel communication | A20(Front Panel) | Check A20 and connection. |
| 2113 | Front panel RAM | A20(Front Panel) | Check A20 and connection. |
| 2114 | Front panel ROM | A20(Front Panel) | Check A20 and connection. |
| 2115 | Front panel A/D | A20(Front Panel) | Check A20 and connection. |
| 2116 | Front panel timer | A20(Front Panel) | Check A20 and connection. |
| 2700 | Calibration data failure | Flash Disk | Also possible no calibration after A50/A52/A7x were exchanged. |
| 2701 | Calibration data not found | Flash Disk | Also possible no calibration after A50/A52/A7x were exchanged. |
| 2702 | Calibration data checksum | Flash Disk | Also possible no calibration after A50/A52/A7x were exchanged. |
| 2703 | Calibration data invalid | Flash Disk | Also possible no calibration after A50/A52/A7x were exchanged. |
| <i>/* ---- Run Mode Diagnostics ---- */</i> | | | |
| 3000 | Run mode failure | A50(SEQ) | Check A50(SEQ). |
| 3100 | Run mode Control register failure | A50(SEQ) | Check A50(SEQ). |
| 3101-3132 | Run mode Control register bit0 to bit31 | A50(SEQ) | Check A50(SEQ). |
| <i>/* ---- Clock Diagnostics ---- */</i> | | | |
| 4000 | Clock failure | A50(SEQ) | Check A50(SEQ). |
| 4100 | PLL lock/unlock failure | A50(SEQ) | Check A50(SEQ). |
| <i>/* ---- Sequence Memory Diagnostics ---- */</i> | | | |
| 5000 | Sequence memory failure | A50(SEQ) | Check A50(SEQ). |
| 5100 | Sequence memory data bus failure | A50(SEQ) | Check A50(SEQ). |
| 5101-5132 | Sequence memory data bus bit0 to bit31 | A50(SEQ) | Check A50(SEQ). |
| 5200 | Sequence memory address bus failure | A50(SEQ) | Check A50(SEQ). |
| 5201-5224 | Sequence memory address bus bit0 to bit23 | A50(SEQ) | Check A50(SEQ). |
| 5300 | Sequence memory chip cell failure | A50(SEQ) | Check A50(SEQ). |
| 5301-5302 | Sequence memory chip 0 to chip 1 | A50(SEQ) | Check A50(SEQ). |
| 5350 | Sequence memory chip select failure | A50(SEQ) | Check A50(SEQ). |
| 5351-5352 | Sequence memory chip select 0 to select 1 | A50(SEQ) | Check A50(SEQ). |
| 5600 | Event table memory data bus failure | A50(SEQ) | Check A50(SEQ). |

Table 6-14: Messages and Codes (Cont.)

| Error code | Error message | Related module | Supplementary Information |
|--|---|--------------------------|--|
| 5601-5632 | Event table memory data bus chip 0 chip 32 | A50(SEQ) | Check A50(SEQ). |
| 5700 | Event table memory address data bus failure | A50(SEQ) | Check A50(SEQ). |
| 5701-5704 | Event table memory address data bus chip 0 chip 3 | A50(SEQ) | Check A50(SEQ). |
| 5800 | Event table memory chip call failure | A50(SEQ) | Check A50(SEQ). |
| 5801-5802 | Event table memory chip 0 to chip 1 | A50(SEQ) | Check A50(SEQ). |
| /* ---- Waveform Memory Diagnostics ---- */ | | | |
| 6000 | Waveform memory failure | A6x(Memory)/ A52(AWG) | “Check A60/A61 (Memory), A52(AWG) and connection in CH1” |
| 6100 | CH1 Waveform memory data bus failure | A6x(Memory)/A52(AWG) | “Check A60/A61 (Memory), A52(AWG) and connection in CH1” |
| 6101-6132 | CH1 Waveform memory data bus bit0 to bit31 | A6x(Memory)/A52(AWG) | “Check A60/A61 (Memory), A52(AWG) and connection in CH1” |
| 6200 | CH1 Waveform memory address bus failure | A6x(Memory)/A52(AWG) | “Check A60/A61 (Memory), A52(AWG) and connection in CH1” |
| 6201-6224 | CH1 Waveform memory address bus bit0 to bit23 | A6x(Memory)/A52(AWG) | “Check A60/A61 (Memory), A52(AWG) and connection in CH1” |
| 6300 | CH1 Waveform memory chip cell failure | A6x(Memory)/A52(AWG) | “Check A60/A61 (Memory), A52(AWG) and connection in CH1” |
| 6301-6332 | CH1 Waveform memory chip0 to chip31 | A6x(Memory)/A52(AWG) | “Check A60/A61 (Memory), A52(AWG) and connection in CH1” |
| 6350 | CH1 Waveform memory chip select failure | A6x(Memory)/A52(AWG) | “Check A60/A61 (Memory), A52(AWG) and connection in CH1” |
| 6351-6382 | CH1 Waveform memory chip select 0 to select 31 | A6x(Memory)/A52(AWG) | “Check A60/A61 (Memory), A52(AWG) and connection in CH1” |
| 6400 | CH2 Waveform memory data bus failure | A6x(Memory)/A52(AWG) | “Check A60/A61 (Memory), A52(AWG) and connection in CH2” |
| 6401-6432 | CH2 Waveform memory data bus bit0 to bit31 | A6x(Memory)/A52(AWG) | “Check A60/A61 (Memory), A52(AWG) and connection in CH2” |
| 6500 | CH2 Waveform memory address bus failure | A6x(Memory)/A52(AWG) | “Check A60/A61 (Memory), A52(AWG) and connection in CH2” |
| 6501-6524 | CH2 Waveform memory address bus bit0 to bit23 | A6x(Memory)/A52(AWG) | “Check A60/A61 (Memory), A52(AWG) and connection in CH2” |
| 6600 | CH2 Waveform memory chip cell failure | A6x(Memory)/A52(AWG) | “Check A60/A61 (Memory), A52(AWG) and connection in CH2” |
| 6601-6632 | CH2 Waveform memory chip0 to chip31 | A6x(Memory)/A52(AWG) | “Check A60/A61 (Memory), A52(AWG) and connection in CH2” |
| 6650 | CH2 Waveform memory chip select failure | A6x(Memory)/A52(AWG) | “Check A60/A61 (Memory), A52(AWG) and connection in CH2” |

Table 6-14: Messages and Codes (Cont.)

| Error code | Error message | Related module | Supplementary Information |
|------------------------------------|--|----------------------|---|
| 6651-6682 | CH2 Waveform memory chip select 0 to select 31 | A6x(Memory)/A52(AWG) | “Check A60/A61(Memory), A52(AWG) and connection in CH2” |
| 6700 | CH3 Waveform memory data bus failure | A6x(Memory)/A52(AWG) | “Check A60/A61(Memory), A52(AWG) and connection in CH3” |
| 6701-6732 | CH3 Waveform memory data bus bit0 to bit31 | A6x(Memory)/A52(AWG) | “Check A60/A61(Memory), A52(AWG) and connection in CH3” |
| 6800 | CH3 Waveform memory address bus failure | A6x(Memory)/A52(AWG) | “Check A60/A61(Memory), A52(AWG) and connection in CH3” |
| 6801-6824 | CH3 Waveform memory address bus bit0 to bit23 | A6x(Memory)/A52(AWG) | “Check A60/A61(Memory), A52(AWG) and connection in CH3” |
| 6900 | CH3 Waveform memory chip cell failure | A6x(Memory)/A52(AWG) | “Check A60/A61(Memory), A52(AWG) and connection in CH3” |
| 6901-6932 | CH3 Waveform memory chip0 to chip31 | A6x(Memory)/A52(AWG) | “Check A60/A61(Memory), A52(AWG) and connection in CH3” |
| 6950 | CH3 Waveform memory chip select failure | A6x(Memory)/A52(AWG) | “Check A60/A61(Memory), A52(AWG) and connection in CH3” |
| 6951-6982 | CH3 Waveform memory chip select 0 to select 31 | A6x(Memory)/A52(AWG) | “Check A60/A61(Memory), A52(AWG) and connection in CH3” |
| /* ---- Output Diagnostics ---- */ | | | |
| 7000 | Output failure | A72/70(Output) | Also possible D/A converter and so forth on A52. |
| 7100 | Internal offset failure | A72/70(Output) | Also possible D/A converter and so forth on A52. |
| 7101 | CH1 internal offset | A72/70(Output) | Also possible D/A converter and so forth on A52. |
| 7102 | CH2 internal offset | A72/70(Output) | Also possible D/A converter and so forth on A52. |
| 7103 | CH3 internal offset | A72/70(Output) | Also possible D/A converter and so forth on A52. |
| 7104 | $\overline{\text{CH1}}$ internal offset | A70(Output) | Also possible D/A converter and so forth on A52. |
| 7105 | $\overline{\text{CH2}}$ internal offset | A70(Output) | Also possible D/A converter and so forth on A52. |
| 7106 | $\overline{\text{CH3}}$ internal offset | A70(Output) | Also possible D/A converter and so forth on A52. |
| 7200 | Output offset failure | A72/70(Output) | Check A72/A70 and connection. |
| 7201 | CH1 output offset failure | A72/70(Output) | Check A72/A70 and connection. |
| 7202 | CH2 output offset failure | A72/70(Output) | Check A72/A70 and connection. |
| 7203 | CH3 output offset failure | A72/70(Output) | Check A72/A70 and connection. |
| 7204 | $\overline{\text{CH1}}$ output offset failure | A70(Output) | Check A70 and connection. |
| 7205 | $\overline{\text{CH2}}$ output offset failure | A70(Output) | Check A70 and connection. |
| 7206 | $\overline{\text{CH3}}$ output offset failure | A70(Output) | Check A70 and connection. |
| 7300 | Arb gain failure | A72/70(Output) | Check A72/A70 and connection. |
| 7301 | CH1 Arb gain | A72/70(Output) | Check A72/A70 and connection. |
| 7302 | CH2 Arb gain | A72/70(Output) | Check A72/A70 and connection. |

Table 6-14: Messages and Codes (Cont.)

| Error code | Error message | Related module | Supplementary Information |
|------------|---|----------------|-------------------------------|
| 7303 | CH3 Arb gain | A72/70(Output) | Check A72/A70 and connection. |
| 7304 | $\overline{\text{CH1}}$ Arb gain | A70(Output) | Check A70 and connection. |
| 7305 | $\overline{\text{CH2}}$ Arb gain | A70(Output) | Check A70 and connection. |
| 7306 | $\overline{\text{CH3}}$ Arb gain | A70(Output) | Check A70 and connection. |
| 7400 | Direct Gain failure | A72/70(Output) | Check A72/A70 and connection. |
| 7401 | CH1 Direct Gain | A72/70(Output) | Check A72/A70 and connection. |
| 7402 | CH2 Direct Gain | A72/70(Output) | Check A72/A70 and connection. |
| 7403 | CH3 Direct Gain | A72/70(Output) | Check A72/A70 and connection. |
| 7404 | $\overline{\text{CH1}}$ Direct Gain | A70(Output) | Check A70 and connection. |
| 7405 | $\overline{\text{CH2}}$ Direct Gain | A70(Output) | Check A70 and connection. |
| 7406 | $\overline{\text{CH3}}$ Direct Gain | A70(Output) | Check A70 and connection. |
| 7510 | 5dB attenuator failure | A72/70(Output) | Check A72/A70 and connection. |
| 7511 | CH1 5dB attenuator | A72/70(Output) | Check A72/A70 and connection. |
| 7512 | CH2 5dB attenuator | A72/70(Output) | Check A72/A70 and connection. |
| 7513 | CH3 5dB attenuator | A72/70(Output) | Check A72/A70 and connection. |
| 7514 | $\overline{\text{CH1}}$ 5dB attenuator | A70(Output) | Check A70 and connection. |
| 7515 | $\overline{\text{CH2}}$ 5dB attenuator | A70(Output) | Check A70 and connection. |
| 7516 | $\overline{\text{CH3}}$ 5dB attenuator | A70(Output) | Check A70 and connection. |
| 7520 | 10dB attenuator 1 failure | A72/70(Output) | Check A72/A70 and connection. |
| 7521 | CH1 10dB 1 attenuator | A72/70(Output) | Check A72/A70 and connection. |
| 7522 | CH2 10dB 1 attenuator | A72/70(Output) | Check A72/A70 and connection. |
| 7523 | CH3 10dB 1 attenuator | A72/70(Output) | Check A72/A70 and connection. |
| 7524 | $\overline{\text{CH1}}$ 10dB 1 attenuator | A70(Output) | Check A70 and connection. |
| 7525 | $\overline{\text{CH2}}$ 10dB 1 attenuator | A70(Output) | Check A70 and connection. |
| 7526 | $\overline{\text{CH3}}$ 10dB 1 attenuator | A70(Output) | Check A70 and connection. |
| 7530 | 10dB attenuator 2 failure | A72/70(Output) | Check A72/A70 and connection. |
| 7531 | CH1 10dB 2 attenuator | A72/70(Output) | Check A72/A70 and connection. |
| 7532 | CH2 10dB 2 attenuator | A72/70(Output) | Check A72/A70 and connection. |
| 7533 | CH3 10dB 2 attenuator | A72/70(Output) | Check A72/A70 and connection. |
| 7534 | $\overline{\text{CH1}}$ 10dB 2 attenuator | A70(Output) | Check A70 and connection. |
| 7535 | $\overline{\text{CH2}}$ 10dB 2 attenuator | A70(Output) | Check A70 and connection. |
| 7536 | $\overline{\text{CH3}}$ 10dB 2 attenuator | A70(Output) | Check A70 and connection. |
| 7540 | 20dB attenuator failure | A72/70(Output) | Check A72/A70 and connection. |
| 7541 | CH1 20dB attenuator | A72/70(Output) | Check A72/A70 and connection. |
| 7542 | CH2 20dB attenuator | A72/70(Output) | Check A72/A70 and connection. |

Table 6-14: Messages and Codes (Cont.)

| Error code | Error message | Related module | Supplementary Information |
|-------------------|--|-----------------------|----------------------------------|
| 7543 | CH3 20dB attenuator | A72/70(Output) | Check A72/A70 and connection. |
| 7544 | $\overline{\text{CH1}}$ 20dB attenuator | A70(Output) | Check A70 and connection. |
| 7545 | $\overline{\text{CH2}}$ 20dB attenuator | A70(Output) | Check A70 and connection. |
| 7546 | $\overline{\text{CH3}}$ 20dB attenuator | A70(Output) | Check A70 and connection. |
| 7610 | 1MHz filter failure | A72/70(Output) | Check A72/A70 and connection. |
| 7611 | CH1 1MHz filter | A72/70(Output) | Check A72/A70 and connection. |
| 7612 | CH2 1MHz filter | A72/70(Output) | Check A72/A70 and connection. |
| 7613 | CH3 1MHz filter | A72/70(Output) | Check A72/A70 and connection. |
| 7614 | $\overline{\text{CH1}}$ 1MHz filter | A70(Output) | Check A70 and connection. |
| 7615 | $\overline{\text{CH2}}$ 1MHz filter | A70(Output) | Check A70 and connection. |
| 7616 | $\overline{\text{CH3}}$ 1MHz filter | A70(Output) | Check A70 and connection. |
| 7620 | 5MHz filter failure | A72/70(Output) | Check A72/A70 and connection. |
| 7621 | CH1 5MHz filter | A72/70(Output) | Check A72/A70 and connection. |
| 7622 | CH2 5MHz filter | A72/70(Output) | Check A72/A70 and connection. |
| 7623 | CH3 5MHz filter | A72/70(Output) | Check A72/A70 and connection. |
| 7624 | $\overline{\text{CH1}}$ 5MHz filter | A70(Output) | Check A70 and connection. |
| 7625 | $\overline{\text{CH2}}$ 5MHz filter | A70(Output) | Check A70 and connection. |
| 7626 | $\overline{\text{CH3}}$ 5MHz filter | A70(Output) | Check A70 and connection. |
| 7630 | 20MHz filter failure | A72/70(Output) | Check A72/A70 and connection. |
| 7631 | CH1 20MHz filter | A72/70(Output) | Check A72/A70 and connection. |
| 7632 | CH2 20MHz filter | A72/70(Output) | Check A72/A70 and connection. |
| 7633 | CH3 20MHz filter | A72/70(Output) | Check A72/A70 and connection. |
| 7634 | $\overline{\text{CH1}}$ 20MHz filter | A70(Output) | Check A70 and connection. |
| 7635 | $\overline{\text{CH2}}$ 20MHz filter | A70(Output) | Check A70 and connection. |
| 7636 | $\overline{\text{CH3}}$ 20MHz filter | A70(Output) | Check A70 and connection. |
| 7640 | 50MHz filter failure | A72/70(Output) | Check A72/A70 and connection. |
| 7641 | CH1 50MHz filter | A72/70(Output) | Check A72/A70 and connection. |
| 7642 | CH2 50MHz filter | A72/70(Output) | Check A72/A70 and connection. |
| 7643 | CH3 50MHz filter | A72/70(Output) | Check A72/A70 and connection. |
| 7644 | $\overline{\text{CH1}}$ 50MHz filter | A70(Output) | Check A70 and connection. |
| 7645 | $\overline{\text{CH2}}$ 50MHz filter | A70(Output) | Check A70 and connection. |
| 7646 | $\overline{\text{CH3}}$ 50MHz filter | A70(Output) | Check A70 and connection. |
| 9111 | Waveform/Sequence load error: waveform memory full | - | |

Table 6-14: Messages and Codes (Cont.)

| Error code | Error message | Related module | Supplementary Information |
|-------------------|---|-----------------------|----------------------------------|
| 9112 | Waveform/Sequence load error: invalid waveform length | - | |
| 9113 | Waveform/Sequence load error: waveform length too short | - | |
| 9114 | Waveform/Sequence load error: waveform length changed | - | |
| 9121 | Sequence load error: missing file name in sequence | - | |
| 9122 | Sequence load error: too many nesting levels | - | |
| 9123 | Sequence load error: infinite loop in sub-sequence | - | |
| 9124 | Sequence load error: infinite sub-sequence loop | - | |
| 9125 | Sequence load error: max sequence elements exceeded | - | |
| 9126 | Sequence load error: invalid jump address | - | |
| 9127 | Sequence load error: sequence memory full | - | |
| 9128 | Sequence load error: infinite loop and Goto One not allowed | - | |
| 9151 | Waveform load warning: output disabled in some channels | - | |
| 9152 | Waveform/Sequence output warning: output disabled | - | |

Options and Accessories

This appendix describes the various options as well as the standard and optional accessories that are available for the AWG400-Series.

Power Cord Options

Table 7-1 lists the power cords available with the AWG400-Series.

Table 7-1: Power cord identification

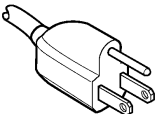
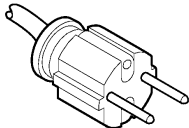
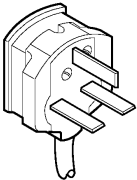
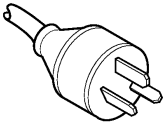
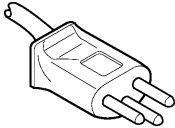
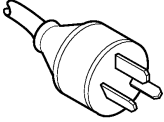
| Plug configuration | Normal usage | Option number |
|---|-------------------------|---------------|
|  | North America 125 V | Standard |
|  | Europe 230 V | A1 |
|  | United Kingdom 230 V | A2 |
|  | Australia 230 V | A3 |
|  | Switzerland 230 V | A5 |
|  | China 230 V | AC |
| | No power cord supplied. | A99 |

Options

This subsection describes the following options available with the AWG400-Series Arbitrary Waveform Generator:

Option D1 (Test Result Report)

A calibration data test result report will be provided with the AWG400-Series Arbitrary Waveform Generator when this option is specified.

Option 1R (Rack Mounting)

AWG400-Series Arbitrary Waveform Generator comes configured for installation in a 19-inch wide instrument rack. For later field conversions, order Tektronix part number 020-A045-00.

Option 01 (16 Mbyte Memory)

Each channel waveform memory serves as 16 M word per channel. For later field upgrades, order Tektronix part numbers: 020-A046-00 for AWG410, 020-A047-00 for AWG420, 020-A048-00 for AWG430.

Option 03 (Digital Data Out)

The function of digital data out outputs digital data from waveform memory through P4116 CMOS 16-Bits digital data output pod bypassing the D/A and output circuitry.

Option 05 (Single Ended Analog Out)

The complementary analog output of each channel turns into a single ended output.

Option 10 (Flash disk, alternate HDD & Standby Switch)

A 128 Mbyte flash disk addition. The hard disk is deleted when this option is ordered.

The AWG400-Series retains the state of the front panel ON/STBY switch. The ON/STBY switch must be left in the on position to be able to power on and power off the instrument using the principal power switch.

NOTE. *If the ON/STBY switch is left in the off position, you will not be able to power on/off the instrument using the principal power switch or an external power switch unit.*

Accessories

Standard Accessories The AWG400-Series Arbitrary Waveform Generator includes the standard accessories listed in Table 7–2:

Table 7–2: Standard accessories

| Accessory | Part number |
|--|-----------------|
| User Manual | 070-A809-52 |
| Programmer Manual | 070-A810-50 |
| Sample waveform floppy disk, 3.5 inch | 062-A257-XX |
| Sample program floppy disk, 3.5 inch | 062-A258-XX |
| Performance check/adjustment floppy disk, 3.5 inch | 062-A259-XX |
| Arb-Express Software Package, CD-R | 063-3763-XX |
| Arb-Express Software Package, Instructions | 061-4288-XX |
| Power Cord (except A99) | (see Table 7–1) |
| Certificate of Traceable Calibration | Not Orderable |

Optional Accessories The following optional accessories, listed in Table 7–3, are recommended for use with the instrument:

Table 7–3: Optional accessories

| Accessory | Part number |
|--|-------------|
| Service Manual | 070-A811-52 |
| Front cover | 200-3696-01 |
| SMB – Pin Header Cable Set (seventeen (17) 012-1503-00 and a Housing Shell) | 012-A217-00 |
| Pin Header – Pin Header Cable Set (seventeen (17) 012-1505-00 and two Housing Shell) | 012-A218-00 |
| SMB – Pin Header Cable (20 in) | 012-1503-00 |
| Pin Header – Pin Header Cable | 012-1505-00 |
| SMB to BNC adapter | 015-0671-00 |
| GPIB cable | 012-0991-00 |
| BNC cable, 50 Ω , 0.61 m (24 in) | 012-1342-00 |
| BNC cable, 50 Ω , 1.07 m (42 in) | 012-0057-01 |
| BNC cable, 50 Ω , 0.98 m (38.6 in) double-shield | 012-1256-00 |

Table 7-3: Optional accessories (cont.)

| Accessory | Part number |
|--|--|
| SMB-SMB cable, 50 Ω , 1 m (3.3 ft) double-shield | 012-1458-00 |
| SMB-BNC cable, 50 Ω , 1 m (3.3 ft) double-shield | 012-1459-00 |
| BNC terminator, 50 Ω | 011-0049-01 |
| BNC power divider, 50 Ω , DC to 300 MHz, VSWR: 1.2 max. | 015-0660-00 |
| BNC low pass filter, 100 MHz | 015-0657-00 |
| Cart | K475 |
| Rack Mount Kit (for field conversion) | 020-A045-00 |
| P4116 Digital Data Output Pod | 116-A015-00 |
| 16 MB Memory upgrade kit | 020-A046-00 (AWG410) 020-A047-00 (AWG420) 020-A048-00 (AWG430) |



Electrical Parts List

The modules that make up this instrument are a combination of mechanical and electrical subparts. Therefore, all replaceable modules are listed in *Replaceable-Mechanical Parts*. Refer to that section for part numbers when using this manual.

Diagrams

This section contains following diagram:

- Block & Interconnect Diagram for the AWG400-Series

This diagram shows the modules and functional blocks in the waveform generator. And it also shows how the modules in the waveform generator connect together.

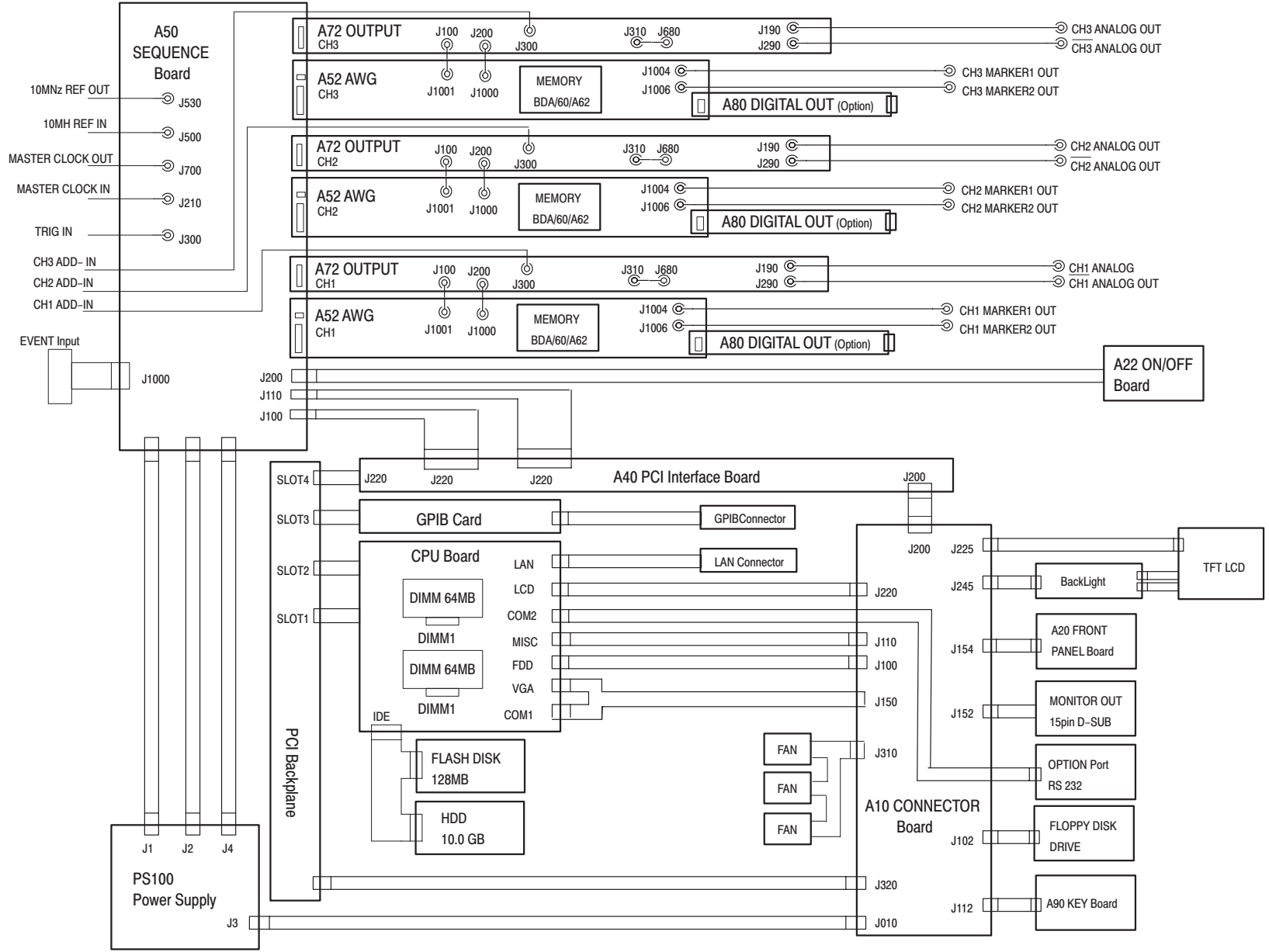

This table contains cable assembling parts.

These parts used for connecting a connection point A and a connection point B in the table. These connection points correspond to the diagram in the previous page.

Refer to replaceable mechanical parts section for the information about these parts.

Cable Assembling Parts List

| Tektronix part number | Connection point. A | Connection point. B |
|------------------------------|----------------------------|--|
| 174-B896-00 | A50 SEQUENCE Board:J530 | 10MHz REF OUT |
| 174-B895-00 | A50 SEQUENCE Board:J500 | 10MHz REF IN |
| 174-B873-00 | A50 SEQUENCE Board:J700 | MASTER CLOCK OUT |
| 174-B894-00 | A50 SEQUENCE Board:J210 | MASTER CLOCK IN |
| 174-B872-00 | A50 SEQUENCE Board:J300 | TRIG IN |
| 174-B876-00 | A72 OUTPUT :J300 | CH3 ADD-IN |
| 174-B875-00 | A72 OUTPUT:J300 | CH2 ADD-IN |
| 174-B874-00 | A72 OUTPUT:J300 | CH1 ADD-IN |
| 174-B878-00 | A50 SEQUENCE Board:J1000 | EVENT INPUT |
| 174-B879-00 | A50 SEQUENCE Board: | PS100 Power Supply:J1 |
| 174-B880-00 | A50 SEQUENCE Board: | PS100 Power Supply:J2 |
| 174-B881-00 | A50 SEQUENCE Board: | PS100 Power Supply:J4 |
| 174-B883-00 | A50 SEQUENCE Board:J100 | A40 J220 |
| 174-4315-00 | A50 SEQUENCE Board:J110 | A40 J220 |
| 174-B882-00 | A50 SEQUENCE Board:J200 | A22 ON/OFF Board |
| 174-3200-00 | A52:J1001 | A72 J100 |
| 174-B693-00 | A52:J1000 | A72 J200 |
| 174-B897-00 | A72:J310 | A72 J680 |
| 174-3200-00 | A72:J190 | CH1,CH2,CH3 ANALOG OUT |
| 174-B693-00 | A72:J290 | $\overline{\text{CH1}}, \overline{\text{CH2}}, \overline{\text{CH3}}$ ANALOG OUT |
| 174-4306-00 | A52:J1004 | CH1,2,3 MARKER1 OUT |
| 174-4306-00 | A52:J1006 | CH1,2,3 MARKER2 OUT |
| 174-B884-00 | GPIB:Card | GPIB Connector |
| 174-B885-00 | CPU Board:LAN | LAN Connector |
| 174-4302-00 | CPU:LCD | A10 J220 |
| 174-B335-00 | CPU:MICS | A10 J110 |
| 174-B334-00 | CPU:FDD | A10 J100 |
| 174-4298-00 | CPU:VGA,CPU:COM1 | A10 J150 |

Cable Assembling Parts List (Cont.)

| Tektronix part number | Connection point. A | Connection point. B |
|------------------------------|----------------------------|----------------------------|
| 174-B892-00 | A10 J310 | FAN |
| 174-B891-00 | CPU:IDE | FLASH DISK,HDD |
| 174-B887-00 | A10:J310 | PCI Backplane |
| 174-B356-00 | A10:J320 | PS100 Power supply |
| 174-B338-00 | A10:J112 | A90 Key Board |
| 174-B329-00 | A10:J102 | FLOPPY DISK |
| 174-B890-00 | CPU:COM2 | OPTION PORT |
| 174-3879-00 | A10:J152 | MONITOR OUT |
| 174-B337-00 | A10:J154 | A20 |
| 174-B889-00 | A10:J245 | BACK LIGHT |
| 174-B888-00 | A10:J225 | LCD |
| 174-B886-00 | A10:J200 | A40:J200 |

Replaceable Mechanical Parts

This section contains a list of the replaceable modules for the AWG400-Series Arbitrary Waveform Generator. Use this list to identify and order replacement parts.

Parts Ordering Information

Replacement parts are available through your local Tektronix field office or representative.

Changes to Tektronix instruments are sometimes made to accommodate improved components as they become available and to give you the benefit of the latest circuit improvements. Therefore, when ordering parts, it is important to include the following information in your order.

- Part number
- Instrument type or model number
- Instrument serial number
- Instrument modification number, if applicable

If you order a part that has been replaced with a different or improved part, your local Tektronix field office or representative will contact you concerning any change in part number.

Change information, if any, is located at the rear of this manual.

Part Number Revision Level

Tektronix part numbers contain two digits that show the revision level of the part. For most parts in this manual, you will find the letters XX in place of the revision level number.



When you order parts, Tektronix will provide you with the most current part for your product type, serial number, and modification (if applicable). At the time of your order, Tektronix will determine the part number revision level needed for your product, based on the information you provide.

Module Servicing

Modules can be serviced by selecting one of the following three options. Contact your local Tektronix service center or representative for repair assistance.

Module Exchange. In some cases you may exchange your module for a remanufactured module. These modules cost significantly less than new modules and meet the same factory specifications. For more information about the module exchange program, call 1-800-TEK-WIDE, extension 6630.

Module Repair and Return. You may ship your module to us for repair, after which we will return it to you.

New Modules. You may purchase replacement modules in the same way as other replacement parts.

Using the Replaceable Parts List

This section contains a list of the mechanical and/or electrical components that are replaceable for the generator. Use this list to identify and order replacement parts. The following table describes each column in the parts list.

Parts List Column Descriptions

| Column | Column name | Description |
|---------|-----------------------|--|
| 1 | Figure & Index Number | Items in this section are referenced by component number. |
| 2 | Tektronix Part Number | Use this part number when ordering replacement parts from Tektronix. |
| 3 and 4 | Serial Number | Column three indicates the serial number at which the part was first effective. Column four indicates the serial number at which the part was discontinued. No entries indicates the part is good for all serial numbers. |
| 5 | Qty | This indicates the quantity of parts used. |
| 6 | Name & Description | An item name is separated from the description by a colon (:). Because of space limitations, an item name may sometimes appear as incomplete. Use the U.S. Federal Catalog handbook H6-1 for further item name identification. |
| 7 | Mfr. Code | This indicates the code of the actual manufacturer of the part. (Code to name and address cross reference is located after this page.) |
| 8 | Mfr. Part Number | This indicates the actual manufacturer's or vendor's part number. |

Abbreviations

Abbreviations conform to American National Standard ANSI Y1.1-1972.

Mfr. Code to Manufacturer Cross Index

The following table cross indexes codes, names, and addresses of manufacturers or vendors of components listed in the parts list.

Manufacturers Cross Index

| Mfr. code | Manufacturer | Address | City, state, zip code |
|------------------|--|---|------------------------------|
| S3109 | FELLER | 72 VERONICA AVE UNIT 4 | SUMMERSET NJ 08873 |
| TK0392 | NORTHWEST FASTENER SALES INC | 8058 SW NIMBUS AVENUE | BEAVERTON OR 97008 |
| TK0435 | LEWIS SCREW CO | 4300 S RACINE AVE | CHICAGO IL 60609-3320 |
| TK1163 | POLYCAST INC | 9898 SW TIGARD ST | TIGARD OR 97223 |
| TK1287 | ENOCH MFG CO | 14242 SE 82ND DR PO BOX 98 | CLACKAMAS OR 97015 |
| TK1908 | PLASTIC MOLDED PRODUCTS | 4336 SO ADAMS | TACOMA WA 98409 |
| TK1918 | SHIN-ETSU POLYMER AMERICA INC | 1181 NORTH 4TH ST | SAN JOSE CA 95112 |
| TK2058 | TDK CORPORATION OF AMERICA | 1600 FEEHANVILLE DRIVE | MOUNT PROSPECT, IL 60056 |
| TK2432 | UNION ELECTRIC | 15/F #1, FU-SHING N. ROAD | TAIPEI, TAIWAN ROC |
| TK2548 | XEROX BUSINESS SERVICES DIV OF XEROX CORPORATION | 14181 SW MILLIKAN WAY | BEAVERTON OR 97077 |
| OJR05 | TRIQUEST CORP | 3000 LEWIS AND CLARK HWY | VANCOUVER WA 98661-2999 |
| OKB01 | STAUFFER SUPPLY | 810 SE SHERMAN | PORTLAND OR 97214 |
| 00779 | AMP INC | 2800 FULLING MILL PO BOX 3608 | HARRISBURG PA 17105 |
| 07416 | NELSON NAME PLATE CO | 3191 CASITAS | LOS ANGELES CA 90039-2410 |
| 2W733 | BELDEN CORPORATION | 2200 US HIGHWAY 27 SOUTH PO BOX 1980 | RICHMOND IN 47375-0010 |
| 24931 | SPECIALTY CONNECTOR CO INC | 2100 EARLYWOOD DR PO BOX 547 | FRANKLIN IN 46131 |
| 6D224 | HARBOR TRI-TEC A BERG ELECTRONICS COMPANY | 14500 SOUTH BROADWAY | GARDENA, CA 90248 |
| 61058 | MATSUSHITA ELECTRIC CORP OF AMERICA PANASONIC INDUSTRIAL CO DIV | TWO PANASONIC WAY | SECAUCUS NJ 07094 |
| 61857 | SAN-0 INDUSTRIAL CORP | 91-3 COLIN DRIVE | HOLBROOK NY 11741 |
| 61935 | SCHURTER INC | 1016 CLEGG COURT | PETALUMA CA 94952-1152 |
| 64537 | KDI/TRIANGLE ELECTRONICS | 60 S JEFFERSON ROAD | WHIPPANY, NJ 07981 |
| 73743 | FISCHER SPECIAL MFG CO | 111 INDUSTRIAL RD | COLD SPRING KY 41076-9749 |
| 75915 | LITTELFUSE TRACOR INC SUB OF TRACOR INC | 800 E NORTHWEST HWY | DES PLAINES IL 60016-3049 |
| 78189 | ILLINOIS TOOL WORKS INC SHAKEPROOF DIV | ST CHARLES ROAD | ELGIN IL 60120 |
| 80009 | TEKTRONIX INC | 14150 SW KARL BRAUN DR PO BOX 500 | BEAVERTON OR 97077-0001 |
| 86928 | SEASTROM MFG CO INC | 701 SONORA AVE | GLENDALE CA 91201-2431 |
| 98291 | SEAELECTRO CORP BICC ELECTRONICS | 40 LINDEMAN DR | TURNBULL CT 06611-4739 |

Replaceable Parts List

| Fig. & index number | Tektronix part number | Serial no. effective | Serial no. discont'd | Qty | Name & description | Mfr. code | Mfr. part number |
|---------------------|-----------------------|----------------------|----------------------|------|---|-----------|------------------|
| 10-1 | | | | | FRONT AND DISPLAY UNIT | | |
| -1 | 334-A566-00 | | | 1 | MARKER, IDENT:MKD AWG410, POLYCARBONATE | | 334-A566-00 |
| | 334-A567-00 | | | 1 | MARKER, IDENT:MKD AWG420, POLYCARBONATE | | 334-A567-00 |
| | 334-A568-00 | | | 1 | MARKER, IDENT:MKD AWG430, POLYCARBONATE | | 334-A568-00 |
| -2 | 101-0142-01 | | | 1 | TRIM,DECORATIVE:FRONT,RACK MOUNT | | 101-0142-00 |
| -3 | 260-2715-00 | | | 1 | ACTUATOR:ELASTOMER MAT,FRONT PANEL,RUBBER | | 260-2715-00 |
| -4 | 259-A001-00 | | | 1 | FLEX CIRCUIT BEZEL BUTTONS | | 259-A001-00 |
| -5 | 348-1276-00 | | | 11CM | GASKET,SHIELD: CONDUCTIVE FORM STRIP,3.3MM X 4.8MM,W/ADHESIVE TAPE,1M L | | 426-A188-00 |
| -6 | 426-A188-00 | | | 1 | FRAME, DISPLAY:MAIN FILTER, AL | | 426-A188-00 |
| -7 | 378-0466-00 | | | 1 | FILTER,LT,CRT SMOKE GRAY,ACRILIC,WITH AR FILM | | 378-0466-00 |
| -8 | 343-A344-00 | | | 1 | RETAINER, FILTER, SST, AWG400 | | 343-A344-00 |
| -9 | 426-A189-00 | | | 1 | FRAME, LCD:PC, BLACK, AWG400 | | 426-A189-00 |
| -10 | 119-B086-00 | | | 1 | DISPLAY MONITOR: 6.4 INCH, COLOR-TFT, 640X480, VGA | SHARP | LQ64D343 |
| -11 | 344-0472-00 | | | 1 | BUSHING:BUSHING,NYLON,GRAY | | 344-0472-00 |
| -12 | 407-A645-00 | | | 1 | BRACKET, LCD:AL, AWG400 | | 407-A645-00 |
| -13 | 119-B087-00 | | | 1 | INVERTER UNIT: IN 9.6-14.4V, FOR DUAL BULB | TDK | CXA-0214 |
| -14 | 211-1036-00 | | | 2 | SCREW,MACHINE M2 X 6MM L,PNH,STL,MFZN-C,CROSS REC,W/FALT&LOCK WASHERS | | 211-1036-00 |
| -15 | 174-B926-00 | | | 1 | CA, ASSY, SP ELEC 31, 28AWG, 15CM L, FD9M-31S-1R BOTH ENDS | | 174-B926-00 |
| -16 | 174-B889-00 | | | 1 | CA, ASSY, SP, ELEC:6, 26AWG, 15CM L, W/HOLDER, 1MM CTR | | 174-B889-00 |
| -17 | 343-0778-00 | | | 1 | CLAMP,LOOP:5.4MM ID,66NYLON | | 343-0778-00 |
| -18 | 211-1036-00 | | | 4 | SCREW,MACHINE M2 X 6MM L,PNH,STL,MFZN-C,CROSS REC,W/FALT&LOCK WASHERS | | 211-1036-00 |
| -19 | 211-0751-00 | | | 4 | SCREW,MACHINE:M3X8MM L,PNH,STL,ZN-C,CROSS REC W/FLAT&LOCK WASHERS | | 211-0751-00 |

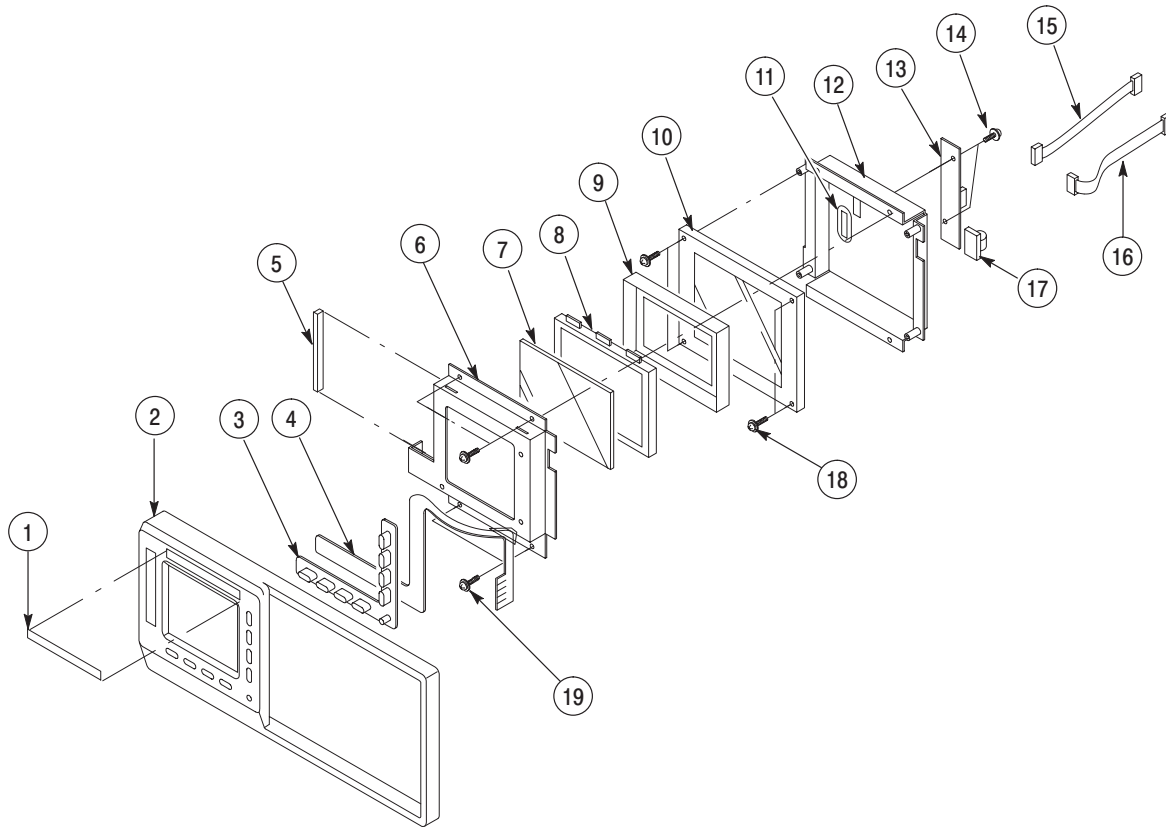

Figure 10-1: Front and Display unit

Replaceable Parts List

| Fig. & index number | Tektronix part number | Serial no. effective | Serial no. discont'd | Qty | Name & description | Mfr. code | Mfr. part number |
|---------------------|-----------------------|----------------------|----------------------|-----|--|-----------|------------------|
| 10-2 | | | | | FRONT PANEL | | |
| -1 | 333-A414-00 | | | 1 | PANEL, FRONT: KEYBOARD, AWG400, POLYCARBONATE | | 333-A414-00 |
| -2 | 386-A838-00 | | | 1 | SUBPANEL, FRONT:KEYBOARD, AL, AWG400 | | 386-A838-00 |
| -3 | 380-0927-01 | | | 1 | HOLDER,SWITCH | | 380-0927-01 |
| -4 | 260-2715-00 | | | 1 | ACTUATOR:ELASTOMER MAT,FRONT PANEL,RUBBER | | 260-2715-00 |
| -5 | 348-1159-00 | | | 2 | SHIELD,ELEC:SST,W/CHEVRONS,0.4 PITCH,8.0L | | 348-1159-00 |
| -6 | 671-B081-01 | | | 1 | CIRCUIT BD ASSY:A20,FRONT PANEL,389-A689-00 WIRED | | 671-B081-01 |
| -7 | 211-0751-00 | | | 6 | SCREW,MACHINE: M3X8MM L,PNH,STL,ZN-C,CROSS REC W/FLAT&LOCK WASHERS | | 211-0751-00 |
| -8 | 377-0579-00 | | | 5 | INSERT,KNOB:PLASTIC | | 337-0579-00 |
| -9 | 348-1160-00 | | | 1 | SHIELD,ELEC:SST,W/CHEVRONS,0.4 PITCH,5.0L | | 348-1160-00 |
| -10 | 124-0469-00 | | | 1 | STRIP,TRIM:FRONT PANEL,AL | | 124-0469-00 |
| -11 | 210-A084-00 | | | 1 | WASHER,PLAIN:M3,NYLON,3.1 X 6.0 X 0.5 | | 210-A084-00 |
| -12 | 366-2170-00 | | | 1 | KNOB:1.700DIA | | 366-2170-00 |
| -13 | 366-2114-00 | | | 2 | KNOB:IVORY GRAY,SCROLL,1.243 IDX 1.4 OD X 0.4 H | | 366-2114-00 |
| -14 | 366-2111-00 | | | 3 | KNOB:IVORY GRAY,SCROLL,1.243 IDX 1.4 OD X 0.4 H | | 366-2111-00 |

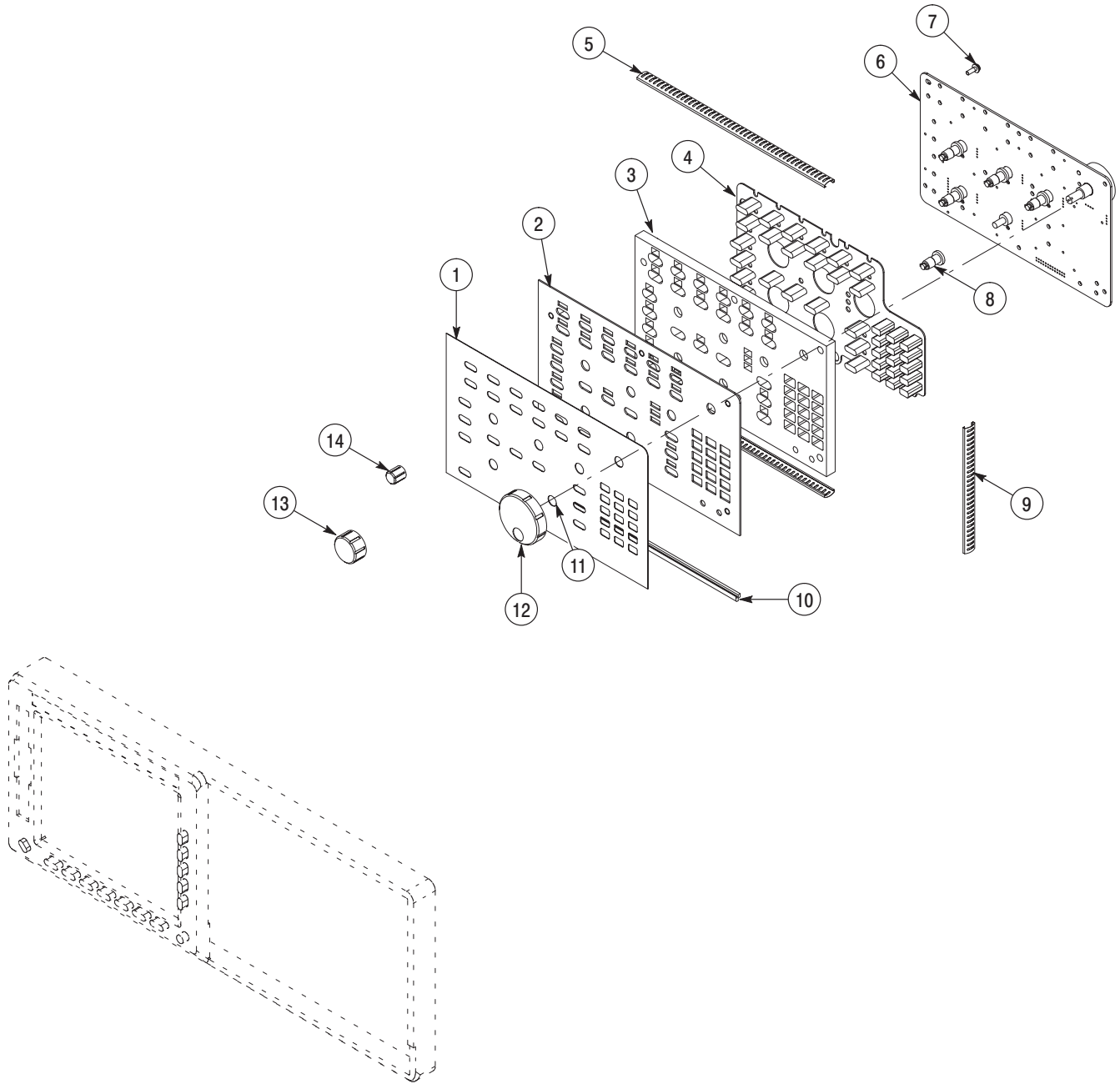

Figure 10-2: Front panel

Replaceable Parts List

| Fig. & index number | Tektronix part number | Serial no. effective | Serial no. discont'd | Qty | Name & description | Mfr. code | Mfr. part number |
|---------------------|-----------------------|----------------------|----------------------|-----|---|-----------|------------------|
| 10-3 | | | | | FRONT OUTPUT UNIT | | |
| -1 | 131-1315-01 | | | 1 | CONN,RF,JACK:BNC,50OHM,FEMALE,STR,PELTORA,PANEL MOUNT | | 131-1315-01 |
| -2 | 671-B091-01 | | | 1 | CIRCUIT BOARD ASSY: A22 ON/OFF KEY BOARD | | 671-B092-00 |
| -3 | 174-3200-00 | | | 1 | CA ASSY,RF:50 OHM COAX,30CM L,9-1,W/PELTORA | | 174-3200-00 |
| -4 | 366-A054-00 | | | 2 | PUSH BUTTON:TEK TAN, ABS, AWG410 | | 366-A054-00 |
| | | | | 4 | AWG420 | | |
| | | | | 6 | AWG430 | | |
| | | | | 1 | AWG410-Op05 | | |
| | | | | 2 | AWG420-Op05 | | |
| | | | | 3 | AWG430-Op05 | | |
| -5 | 343-0549-00 | | | 1 | STRAP,TIEDOWN:1.6-19MM DIA,66NYLON | | 343-0549-00 |
| -6 | 211-0751-00 | | | 5 | SCREW,MACHINE:M3X8MM L,PNH,STL,ZN-C,CROSS REC W/FLAT&LOCK WASHERS | | 211-0751-00 |
| -7 | 333-A417-00 | | | 1 | PANEL, FRONT: BNC, POLYCARBONATE, AWG410 | | 333-A417-00 |
| | 333-A418-00 | | | 1 | AWG420 | | 333-A418-00 |
| | 333-A419-00 | | | 1 | AWG430 | | 333-A419-00 |
| | 333-A420-00 | | | 1 | AWG410-Op05 | | 333-A420-00 |
| | 333-A421-00 | | | 1 | AWG420-Op05 | | 333-A421-00 |
| | 333-A422-00 | | | 1 | AWG430-Op05 | | 333-A422-00 |
| -8 | 407-A646-00 | | | 1 | BRACKET, ASSY:OUTPUT CONNECTOR, AL, AWG400 | | 407-A646-00 |

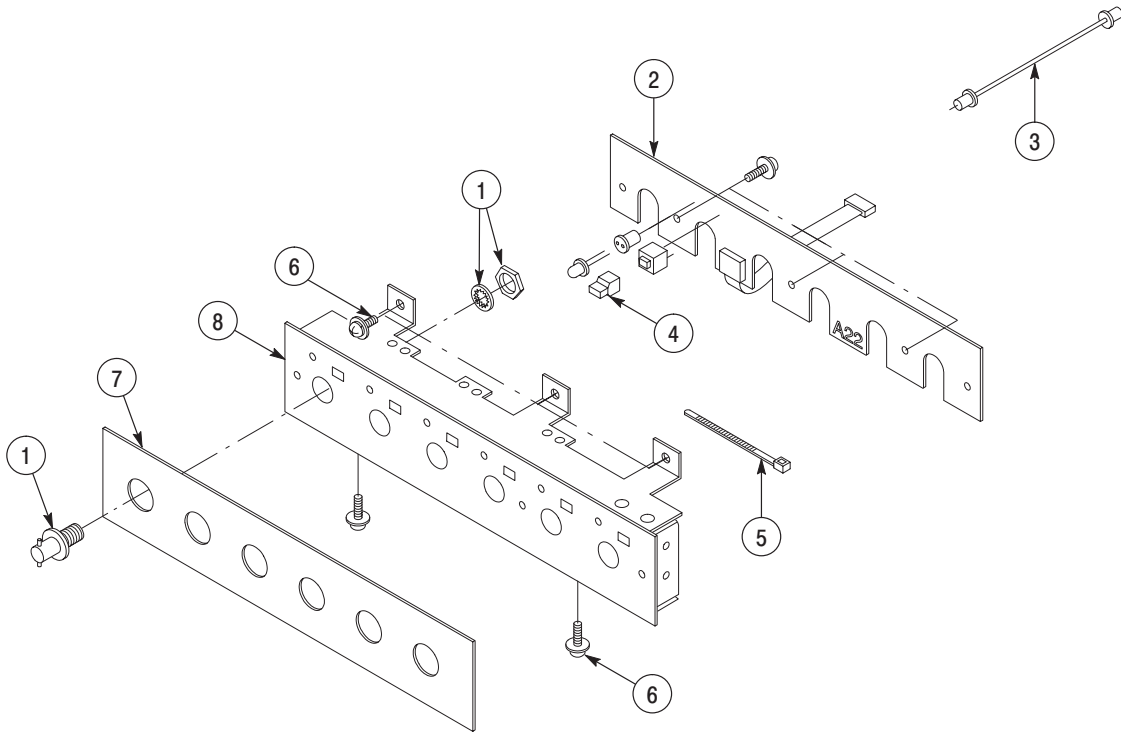

Figure 10-3: Front Output unit

Replaceable Parts List

| Fig. & index number | Tektronix part number | Serial no. effective | Serial no. discont'd | Qty | Name & description | Mfr. code | Mfr. part number |
|---------------------|-----------------------|----------------------|----------------------|-----|---|-------------|------------------|
| 10-4 | | | | | CHASSIS | | |
| -1 | 441-A282-00 | | | 1 | CHASSIS, ASSY:CPU, AL, AWG400, See Fig 10-5 | | 441-A282-00 |
| -2 | 211-0945-00 | | | | SCREW, MACHINE:M4X8MM L,STL,ZN-C,CROSS REC | | 211-0945-00 |
| -3 | 211-0871-00 | | | 5 | SCREW,MACHINE:M3X6MM L,PNH,STL,ZN PL,CROSS REC,W/FLAT(7MM OD)& LOCK WASHER | | 211-0871-00 |
| -4 | 671-B130-00 | | | 1 | CIRCUIT BD ASSY: A10 CONNECTOR, 389-B099-XX WIRED | | 671-B130-00 |
| -5 | 407-A648-00 | | | 1 | BRACKET:HDD, CONNECTOR BD, AL, AWG400 | | 407-A648-00 |
| -6 | 211-0871-00 | | | 7 | SCREW,MACHINE:M3X6MM L,PNH,STL,ZN PL,CROSS REC, W/FLAT(7MM OD)& LOCK WASHER | | 211-0871-00 |
| -7 | 119-B135-00 | | | 1 | HDD UNIT:"2.5", "10.06HB, IDE I/F", FORMATTED | IBM | DJSA-210 |
| -8 | 131-A609-00 | | | 1 | BUS,CONDUCTOR:SHORT BAR,2MM PITCH | | 131-A609-00 |
| -9 | 620-A006-00 | | | 1 | POWER SUPPLY:IN 90-250V, 47-63HZ, OUT +5V/20A, -2V/10A, -5V/18A, +12V/4.7A, 3.3V/20A, +15OR8V/3A, - | FUJI DENKI | FH0410 |
| -10 | 174-B881-00 | | | 1 | CA, ASSY, SP, ELEC:20, 30AWG, FLAT, 13CM L, 0.65CTR | | 174-B881-00 |
| -11 | 174-B880-00 | | | 1 | CA, ASSY, SP, ELEC:12, 22AWG, 26CM L | | 174-B880-00 |
| -12 | 174-B879-00 | | | 1 | CA, ASSY, SP, ELEC:18, 22AWG, 25CM L | | 174-B879-00 |
| -13 | 119-B134-00 | | | 1 | MEMORY MODULE:SOLID STATE DRIVE, 16MB, IDE-I/F F/W INSTALLED | SONY/TEK | 119-XXX-XX |
| -14 | 174-B891-00 | | | 1 | CA, ASSY, SP, ELEC:44, 28AWG, FLAT, 23CM L, 2MM CTR | | 174-B891-00 |
| -15 | 344-0472-00 | | | 3 | BUSHING:BUSHING,NYLON,GRAY | | 344-0472-00 |
| -16 | 174-B356-00 | | | 1 | CABLE, ASSY, SP:PS, 16CON, A10, 7CM, 5557-16R | | 174-B356-00 |
| -17 | 344-A019-00 | | | 2 | CLIP, CABLE:WIRE SADDLE, 16 MM X 15.5 MM, 66 NYLON | | WS-2WS |
| -18 | 343-1644-00 | | | 2 | CLIP, CABLE:WIRE SADDLE, | | UAMS-07-0 |
| -19 | 343-0549-00 | | | 8 | STRAP,TIEDOWN:1.6-19MM DIA,66NYLON | | 343-0549-00 |
| -20 | 211-A044-00 | | | 2 | SCREW,MACHINE:M3X10MML,FLH,STLZNPL,CROSSREC | | 211-A044-00 |
| -21 | 441-A278-00 | | | 1 | CHASSIS, ASSY:AL, AWG400 | | 441-A278-00 |
| -22 | 220-A177-00 | | | 1 | NUT, PLATE:STL, ZN PL | | 220-A177-00 |
| -23 | 344-0472-00 | | | 5 | BUSHING:BUSHING,NYLON,GRAY | | 344-0472-00 |
| -24 | 255-0732-00 | | | CM | PLASTICCHANNEL:1.7MMX3.7MMX4.0MM,NATURAL,NYLON | | 255-0732-00 |
| -25 | 211-1082-00 | | | 1 | SCREW,MACHINE: M2.6X10MM L,PNH,STL,ZN-C,CROSS REC,W/FLAT & LOCK WASHER | | 211-1082-00 |
| -26 | 211-1033-00 | | | 1 | SCREW,MACHINE:M2.6X3MM L,PNH,BRS NI PL CROSS REC | | 211-1033-00 |
| -27 | 105-1081-03 | | | 1 | BRACKET,FDD ADAPTOR | | 105-1081-03 |
| -28 | 119-5953-00 | | | 1 | FD DRIVE | | 119-5953-00 |
| -29 | 211-A218-00 | | | 1 | SCREW,MACHINE:M2.6X6MML,PNH,STL,ZN-C,CROSSREC W/LOCK&FLAT | | 211-A218-00 |
| -30 | 174-B329-01 | | | 1 | CA ASSY,SP,ELEC:26 COND,150MM,FFC | | 174-B329-01 |
| -31 | 344-0472-00 | | | 3 | BUSHING,NYLON,GRAY | | 344-0472-00 |
| -32 | 119-B103-00 | | | 2 | FAN, TUBEAXIAL:12V, 225MA, 2.7W, 2950RPM, 56.8CFM, 42.1PA, FBA09A12HZ, W/O LEAD | MATSU SHITA | FBA09A12HZ |

Replaceable Parts List (Cont.)

| Fig. & index number | Tektronix part number | Serial no. effective | Serial no. discont'd | Qty | Name & description | Mfr. code | Mfr. part number |
|---------------------|-----------------------|----------------------|----------------------|-----|---|-------------|------------------|
| -33 | 129-A229-00 | | | 4 | SPACER, POST:20.0MM L, M4 INT/EXT THD, 7MM HEX, STL ZN-C PL | | UN237-P4 |
| -34 | 210-0008-00 | | | 1 | WASHER, LOCK:#8 INTL, 0.02 THK, STL CD PL | | 210-0008-00 |
| -35 | 174-B892-00 | | | 1 | CA, ASSY, SP, ELEC:6, 26AWG, 26CM L, FOR FAN MOTOR | | 174-B892-00 |
| -36 | 212-A049-00 | | | 8 | SCREW, MACHINE:M4X30MM L, BDGH, STL ZN-C PL, CROSS REC | | 212-A049-00 |
| -37 | 211-1042-00 | | | 4 | SCREW, MACHINE:M4X10MM L, BDGH, STL, ZN PL | | 211-1042-00 |
| -38 | 119-B104-00 | | | 1 | FAN, TUBEAXIAL: 12V, 370MA, 4.44W, 2500RPM, 103.8CFM, 66.7PA, FBL12G12H, W/O LEAD | MATSU SHITA | FBL12G12H |

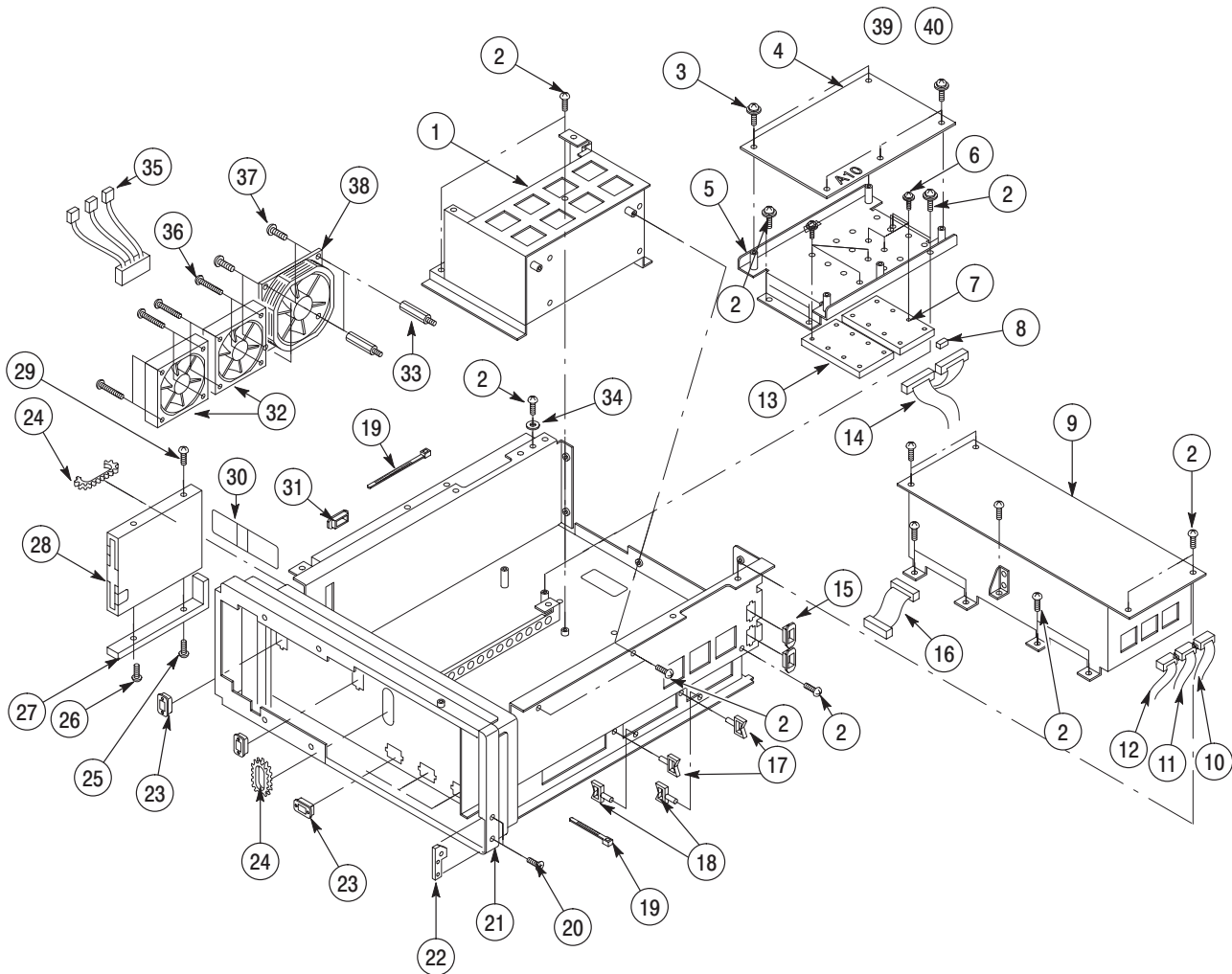

Figure 10-4: Chassis

Replaceable Parts List

| Fig. & index number | Tektronix part number | Serial no. effective | Serial no. discont'd | Qty | Name & description | Mfr. code | Mfr. part number |
|---------------------|-----------------------|----------------------|----------------------|-----|--|-----------|------------------|
| 10-5 | | | | | CPU UNIT | | |
| -1 | 441-A282-00 | | | 1 | CHASSIS, ASSY:CPU, AL, AWG400 | | 441-A282-00 |
| -2 | 343-A345-00 | | | 1 | RETAINER,CKT BD:CPU,AL,AWG400 | | 343-A345-00 |
| -3 | 211-0871-00 | | | 10 | SCREW,MACHINE:M3X6MM L,PNH,STL,ZN PL,CROSS REC,W/FLAT(7MM OD)& LOCK WASHER | | 211-0871-00 |
| -4 | 119-6139-00 | | | 1 | COMPUTER KIT:BACK PLANE BD,3SLOT,PCI BUS | | 119-6139-00 |
| -5 | 119-B136-00 | | | 1 | CPU, UNIT:PENTIUM 133MHZ, W/64MB DIMM, 100BT, HALF-SIZE WITH DIMM AND SET UP | | HPU5810ADA-133 |
| -6 | 671-B129-00 | | | 1 | CIRCUIT BD ASSY:A40 PCI I/F, 389-B102-XX WIRED | | 671-B129-00 |
| -7 | 119-A849-00 | | | 1 | INTERFACE BOARD: PCI-GPIB CARD | | 777440-01 |
| -8 | 407-A647-00 | | | 1 | BRACKET, BOARD:PCI I/F, AL, AWG400 | | 407-A647-00 |
| -9 | 174-B334-00 | | | 1 | CA ASSY, SP, ELEC:34, 28AWG, 9CM L, FLAT | | 174-B334-00 |
| | 174-B335-00 | | | 1 | CA ASSY, SP, ELEC:16, 28AWG, 11CM L, FLAT, DISPLAY | | 174-B336-00 |
| | 174-4298-00 | | | 1 | CA ASSY,SP,ELEC:20CON/9CON/15CON,AWG26,23CM L | | 174-4298-00 |
| | 174-B886-00 | | | 1 | CA, ASSY, SP, ELEC:26, 28AWG, FLAT, 25CM L | | 174-B886-00 |
| | 174-4302-00 | | | 1 | CA ASSY,SP,ELEC:50,AWG28,20CM L,FLAT, 1MM | | 174-4302-00 |
| | 174-B883-00 | | | 1 | CA, ASSY, SP, ELEC:80, 30AWG, FLAT, 27CM L, 0.65CTR | | 174-B883-00 |
| | 174-4315-00 | | | 1 | CA ASSY,SP,ELEC: 100,AWG32,30CM L,FLAT | | 174-4315-00 |
| | 174-B887-00 | | | 1 | CA, ASSY, SP, ELEC:3, 18AWG, 30CM L | | 174-B887-00 |
| -10 | 343-1644-00 | | | | CLAMP,CABLE:CLIP LOCKING WIRE,NYLON | | 343-1644-00 |

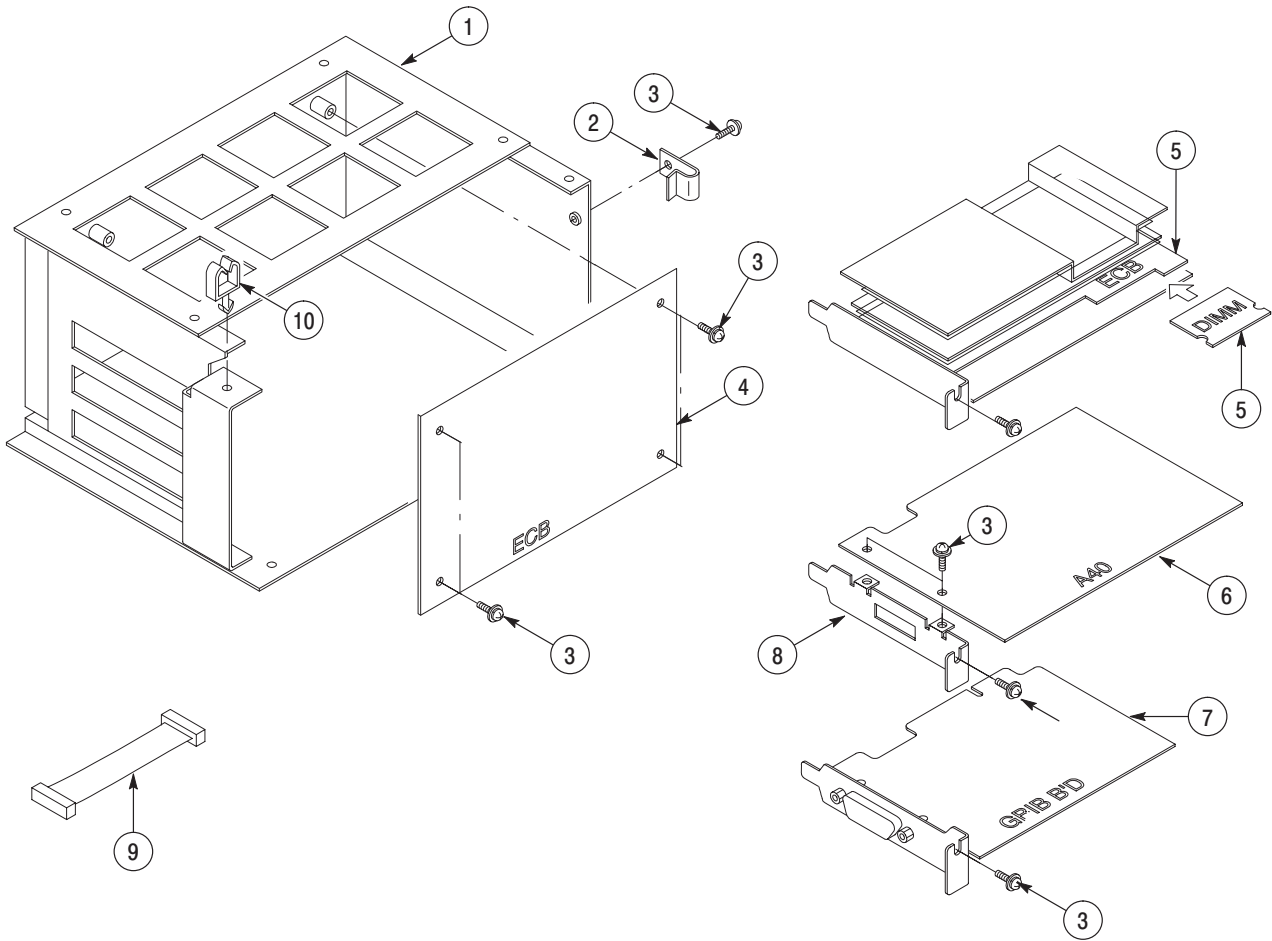

Figure 10-5: CPU unit

Replaceable Parts List

| Fig. & index number | Tektronix part number | Serial no. effective | Serial no. discont'd | Qty | Name & description | Mfr. code | Mfr. part number |
|---------------------|-----------------------|----------------------|----------------------|-----|--|-----------|------------------|
| 10-6 | | | | | BOARD A50, A52, A72, A80 | | |
| -1 | 671-B136-01 | | | 1 | CIRCUIT BD ASSY:A72 COMPLEMENTARY 2V OUTPUT, 389-B108-XX WIRED, AWG410 Op-05 | | 671-B136-01 |
| | | | | 2 | AWG420 Op-05 | | |
| | | | | 3 | AWG430 Op-05 | | |
| | 671-B135-01 | | | 1 | CIRCUIT BD ASSY :A70 SINGLE 5V OUTPUT, AWG410 | | 671-B135-01 |
| | | | | 2 | AWG420 | | |
| | | | | 3 | AWG430 | | |
| -2 | 671-B137-50 | | | 1 | CIRCUIT BD ASSY:A80 DIGITAL OUTPUT, 389-B109-50 WIRED, AWG410 Op-03 | | 671-B137-50 |
| | | | | 2 | AWG420 Op-03 | | |
| | | | | 3 | AWG430 Op-03 | | |
| -3 | 386-A844-00 | | | 1 | STIFFENER:CKT BD, W/SHIELD ELEC, AL, AWG410 | | 386-A844-00 |
| | | | | 2 | AWG420 | | |
| | | | | 3 | AWG430 | | |
| -4 | 386-A843-01 | | | 1 | STIFFENER:CKT BD, AL, AWG410 | | 386-A843-01 |
| | | | | 2 | AWG420 | | |
| | | | | 3 | AWG430 | | |
| -5 | 211-0751-00 | | | EA | SCREW,MACHINE:M3X8MM L,PNH,STL,ZN-C,CROSS REC W/FLAT&LOCK WASHERS | | 211-0751-00 |
| -6 | 211-0871-00 | | | EA | SCREW,MACHINE:M3X6MM L,PNH,STL,ZN PL,CROSS REC,W/FLAT(7MM OD)& LOCK WASHER | | 211-0871-00 |
| -7 | 348-1276-00 | | | 6CM | GASKET,SHIELD:CONDUCTIVE FORM STRIP,3.3MM X 4.8MM, W/ADHESIVE TAPE,1M L | | 348-1276-00 |
| -8 | 131-A793-01 | | | 1 | CONTACT, ELC:GROUNDING, DIGITAL OUT, AWG410 Op-03 | | 131-A793-01 |
| | | | | 2 | AWG420 Op-03 | | |
| | | | | 3 | AWG430 Op-03 | | |
| -9 | 129-A062-00 | | | 3 | SPACER, POST:20.0MM L, M3 INT/EXT THD, 5.5MM HEX, BRS NI P, AWG410 | | SQ-20 |
| | | | | 6 | AWG420 | | |
| | | | | 9 | AWG430 | | |
| -10 | 671-B133-00 | | | 3 | CIRCUIT BD ASSY:A60 4M MEMORY, 389-B105-XX WIRED AWG410 | | 671-B133-00 |
| | | | | 6 | AWG420 | | |
| | | | | 9 | AWG430 | | |
| | 671-B134-00 | | | 3 | CIRCUIT BD ASSY:A62 16M MEMORY, 389-B106-XX WIRED AWG410 Op-01 | | 671-B134-00 |
| | | | | 6 | AWG420 Op-01 | | |
| | | | | 9 | AWG430 Op-01 | | |
| -11 | 348-1203-00 | | | 1 | FOOT,CABINET:CLEAR POLYURETHANE W/ADHESIVE | | 348-1203-00 |
| -12 | 129-A050-00 | | | 2 | SPACER, POST:15.0MM L, M3 INT/EXT THD, BRS, 5.5MM HEX, AWG410 | | SQ-15 |
| | | | | 4 | AWG420 | | |
| | | | | 6 | AWG430 | | |
| -13 | 671-B132-01 | | | 1 | CIRCUIT BD ASSY:A52 AWG, 389-B104-XX WIRED, AWG410 | | 671-B132-00 |
| | | | | 2 | AWG420 | | |
| | | | | 3 | AWG430 | | |
| -14 | 348-1371-00 | | | 4 | FOOT,CABINET:CLEAR POLYURETHANE W/ADHESIVE BACK | | 348-1371-00 |

Replaceable Parts List (Cont.)

| Fig. & index number | Tektronix part number | Serial no. effective | Serial no. discont'd | Qty | Name & description | Mfr. code | Mfr. part number |
|---------------------|-----------------------|----------------------|----------------------|-----|---|-----------|------------------|
| -15 | 671-B131-00 | | | 1 | CIRCUIT BD ASSY:A50 SEQUENCE, 389-B103-XX WIRED | | 671-B131-00 |
| -16 | 129-A589-00 | | | 3 | SPACER, POST:24.0MM L, M3 INT/EXT THD, 5.5MM HEX, BRS NI PL | | SQ-24 |
| -17 | 174-3200-00 | | | 3 | CA ASSY,RF:50 OHM COAX,30CM L,9-1,W/PELTORA | | 174-3200-00 |
| -18 | 174-B897-00 | | | 3 | CA, ASSY, RF:50OHM COAX, 13CM L, 9-N, PELTRA | | 174-B897-00 |

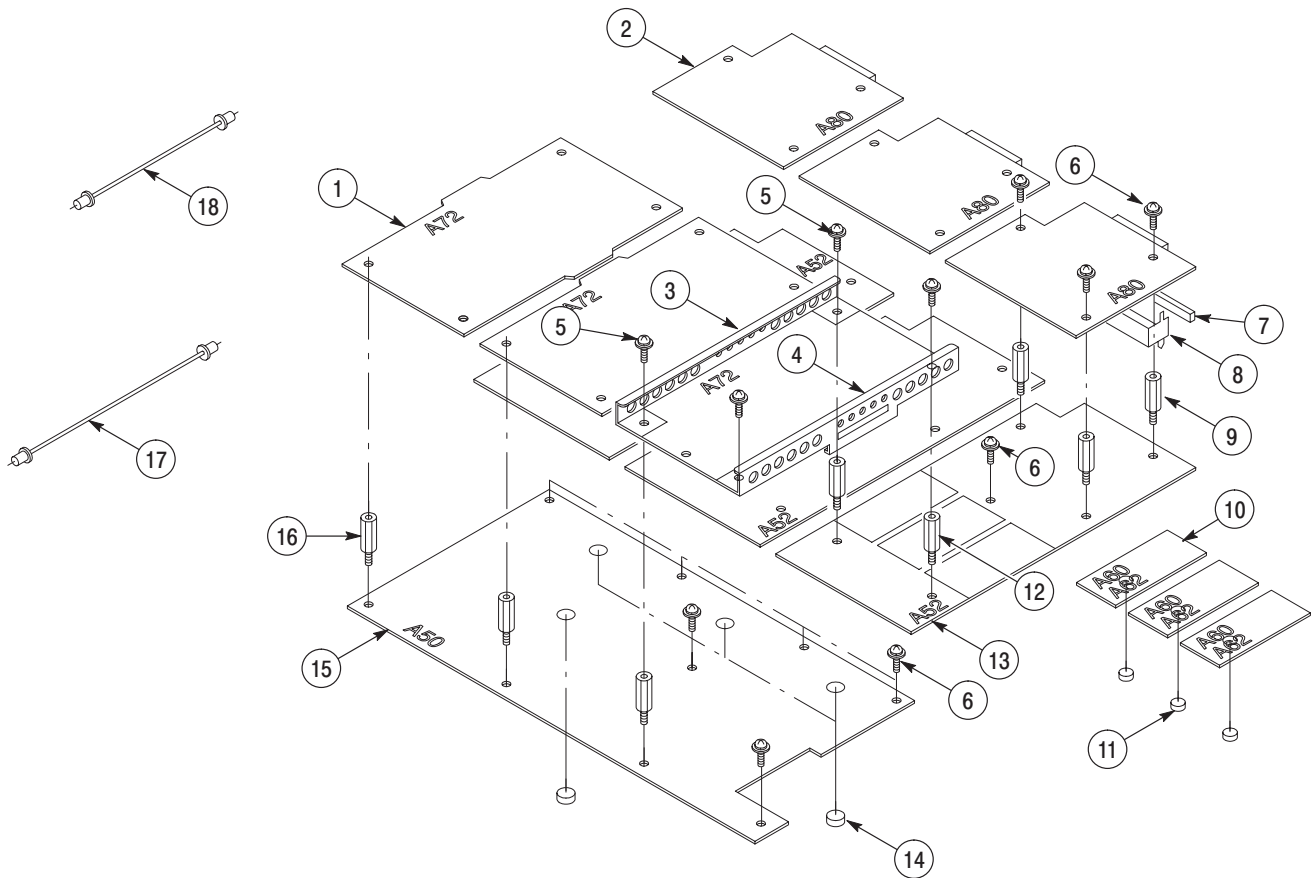

Figure 10-6: Board A50, A52, A72, A80

Replaceable Parts List

| Fig.& index number | Tektronix part number | Serial no. effective | Serial no. discont'd | Qty | Name & description | Mfr. code | Mfr. part number |
|--------------------|-----------------------|----------------------|----------------------|-----|--|-----------|------------------|
| 10-7 | | | | | REAR PANEL | | |
| -1 | 333-A416-01 | | | 1 | PANEL, REAR:AWG400, AL | | 333-A416-01 |
| -2 | 174-B338-00 | | | 1 | CA ASSY, SP, ELEC:6, 26AWG, 43CM L, RIBBON, W/HOLDER, 2MM PITCH | | 174-B338-00 |
| -3 | 131-1315-01 | | | 8 | CONN,RF,JACK:BNC,50OHM,FEMALE,STR,PELTORA,PANEL MOUNT | | |
| -4 | 671-4326-00 | | | 1 | CIRCUIT BD ASSY:A90 KEYBOARD; 389-A695-00 WIRED | | |
| -5 | 174-B885-00 | | | 1 | CA, ASSY, SP, ELEC:8, LAN, 100BASE-T, 35CM L, TWISTED | | 174-B885-00 |
| -6 | 407-4554-00 | | | 1 | BRACKET, CONN:MODULAR CONN | | |
| -7 | 211-0871-00 | | | 1 | SCREW,MACHINE:M3X6MM L,PNH,STL,ZN PL,CROSS REC,W/FLAT(7MM OD)& LOCK WASHER | | |
| -8 | 174-B894-00 | | | | CA, ASSY, RF:50OHM COAX, 60CM L, MKD 21, PELTRA | | 174-B894-00 |
| | 174-B872-00 | | | | CA, ASSY, RF:50OHM COAX, 70CM L, MKD 30, PELTRA | | 174-B872-00 |
| | 174-B895-00 | | | | CA, ASSY, RF:50OHM COAX, 60CM L, MKD 50, PELTR | | 174-B895-00 |
| | 174-B896-00 | | | | CA, ASSY, RF:50OHM COAX, 60CM L, MKD 53, PELTRA | | 174-B896-00 |
| | 174-B873-00 | | | | CA, ASSY, RF:50OHM COAX, 60CM L, MKD 70, PELTRA | | 174-B873-00 |
| | 174-B874-00 | | | | CA, ASSY, RF:50OHM COAX, 70CM L, MKD A1, PELTRA | | 174-B874-00 |
| | 174-B875-00 | | | | CA, ASSY, RF:50OHM COAX, 70CM L, MKD A2, PELTRA | | 174-B875-00 |
| | 174-B876-00 | | | | CA, ASSY, RF:50OHM COAX, 70CM L, MKD A3, PELTRA | | 174-B876-00 |
| -9 | 174-B876-00 | | | | CA, ASSY, RF:50OHM COAX, 70CM L, MKD A3, PELTRA | | 174-B876-00 |
| | 174-4306-00 | | | 6 | CA ASSY,RF:50OHMCOAX,60MM L,8-N | | |
| | 174-B875-00 | | | | CA, ASSY, RF:50OHM COAX, 70CM L, MKD A2, PELTRA | | 174-B875-00 |
| -10 | 220-A176-00 | | | 1 | NUT, PLATE:STL | | 220-A176-00 |
| -11 | 174-B884-00 | | | 1 | CA, ASSY, SP, ELEC: 24, 28AWG, FLAT, 40CM, GPIB | | 174-B884-00 |
| -12 | 131-6383-00 | | | 2 | CONN,RF:BNC,50OHM,FEMALE,STR,SNAP IN/PNL MTG, 12.5MM MLG | | |
| -13 | 211-0945-00 | | | 7 | SCREW, MACHINE:M4X8MM L,STL,ZN-C,CROSS REC | | |
| -14 | 337-A207-01 | | | 3 | SHIELD, ELEC:REAR, AL | | 337-A207-00 |
| -15 | 211-0751-00 | | | 6 | SCREW,MACHINE:M3X8MM L,PNH,STL,ZN-C,CROSS REC W/FLAT&LOCK WASHERS | | |
| -16 | 134-0218-00 | | | 6 | BUTTON,PLUG:0.625 DIA,PLASRIC,TAN | | 134-0218-00 |
| -17 | 174-3879-00 | | | 1 | CA ASSY, SP, ELEC:8,26AWG, 43 CM L, RIBON W/HOLDER, 2MM PITCH | | 174-3879-00 |
| -18 | 174-B890-00 | | | 1 | CA, ASSY, SP, ELEC:9, 28AWG, FLAT, 30CM L, D-SUB9 | | 174-B890-00 |
| -19 | 200-A207-00 | | | 1 | CAP, PROT, DUST:CAP FOR 9 CONTACTS D-SUB, FEMALE, POLYETHYLENE | | 025-5060-000 |
| -20 | 210-A015-00 | | | 6 | WASHER, LOCK:#3, SPLIT, STL MFZN-C | | 210-A015-00 |
| -21 | 214-3903-01 | | | 6 | SCREW,JACK:4-40 X 0.312 EXT THD,4-40 INT THD,0.188 HEX,STEEL,CAD PLATE | | 214-3903-01 |

Replaceable Parts List (Cont.)

| Fig. & index number | Tektronix part number | Serial no. effective | Serial no. discontinued | Qty | Name & description | Mfr. code | Mfr. part number |
|---------------------|-----------------------|----------------------|-------------------------|-----|---|-----------|------------------|
| -22 | 210-A007-00 | | | 6 | WASHER, PLAIN:#3, 6MM OD, STL MFZn-C, KOGATAMARU | | 210-A007-00 |
| -23 | 174-B878-00 | | | 1 | CA, ASSY, SP, ELEC:9, 28AWG, FLAT, 65CM L, D-SUB9 | | 174-B878-00 |
| | 159-0407-XX | | | 1 | FUSE, CARTRIDGE, 3AG, 10A, 350VAC, FAST, 6.35MM X 31.75 MM (0.25 IN X 1.25 IN) | | 159-0407-XX |
| | 159-0210-XX | | | 1 | FUSE, CARTRIDGE, DIN 5 X 20MM, 5A, 250V SLOW BLOW, 5MM X 20MM (.197 IN X .788 IN) | | 159-0210-XX |
| | 200-2264-XX | | | 1 | CAP, FUSEHOLDER, 3AG FUSES | | 200-2264-XX |
| | 200-2265-XX | | | 1 | CAP, FUSEHOLDER, 5 X 20MM FUSES | | 200-2265-XX |

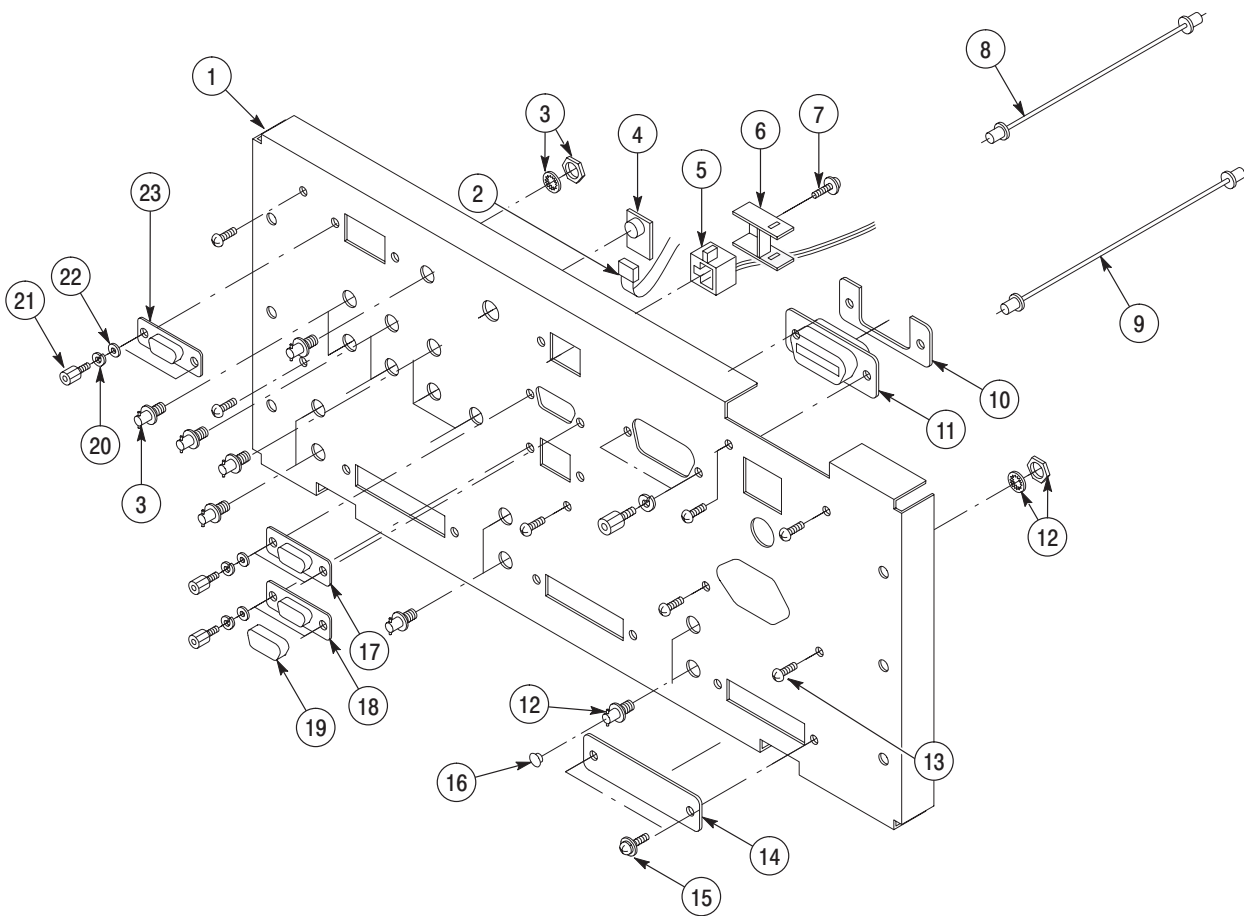

Figure 10-7: Rear Panel

Replaceable Parts List

| Fig.& index number | Tektronix part number | Serial no. effective | Serial no. discont'd | Qty | Name & description | Mfr. code | Mfr. part number |
|---------------------------------------|----------------------------------|---------------------------------|---------------------------------|------------|--|----------------------|-------------------------|
| 10-8 | | | | | CABINET | | |
| -1 | 390-A088-00 | | | 1 | CABINET ASSY:AL, AWG400 | | 390-A088-00 |
| -2 | 348-1314-00 | | | 122 CM | GASKET,SHIELD:FINGER TYPE,BE-CU,609.6MM L,W/ADHESIVE | | 348-1314-00 |
| -3 | 211-0945-00 | | | 2 | SCREW, MACHINE:M4X8MM L,STL,ZN-C,CROSS REC | | 211-0945-00 |
| -4 | 212-0210-00 | | | 6 | SCREW, MACHINE:M5X20MM L,PNH,STL,ZN-C,CROSS REC JIS B111 | | 212-0210-00 |
| -5 | 348-1115-00 | | | 2 | FOOT,CABINET:SLATE GRAY,PLASTIC | | 348-1115-00 |
| -6 | 437-A011-00 | | | 1 | CABINET ASSY:FOOT STAND & CARRING HANDLE, BUILT ON CABINET(390-A088-XX) | | 437-A011-00 |
| -7 | 101-0142-00 | | | 1 | TRIM,DECORATIVE:FRONT | | 101-0142-00 |
| -8 | 348-1569-00 | | | 114 CM | SHILD GASKET, ELEC:MESH TYPE, 3.2MM OD, SI SPONG CORE | | 348-1569-00 |

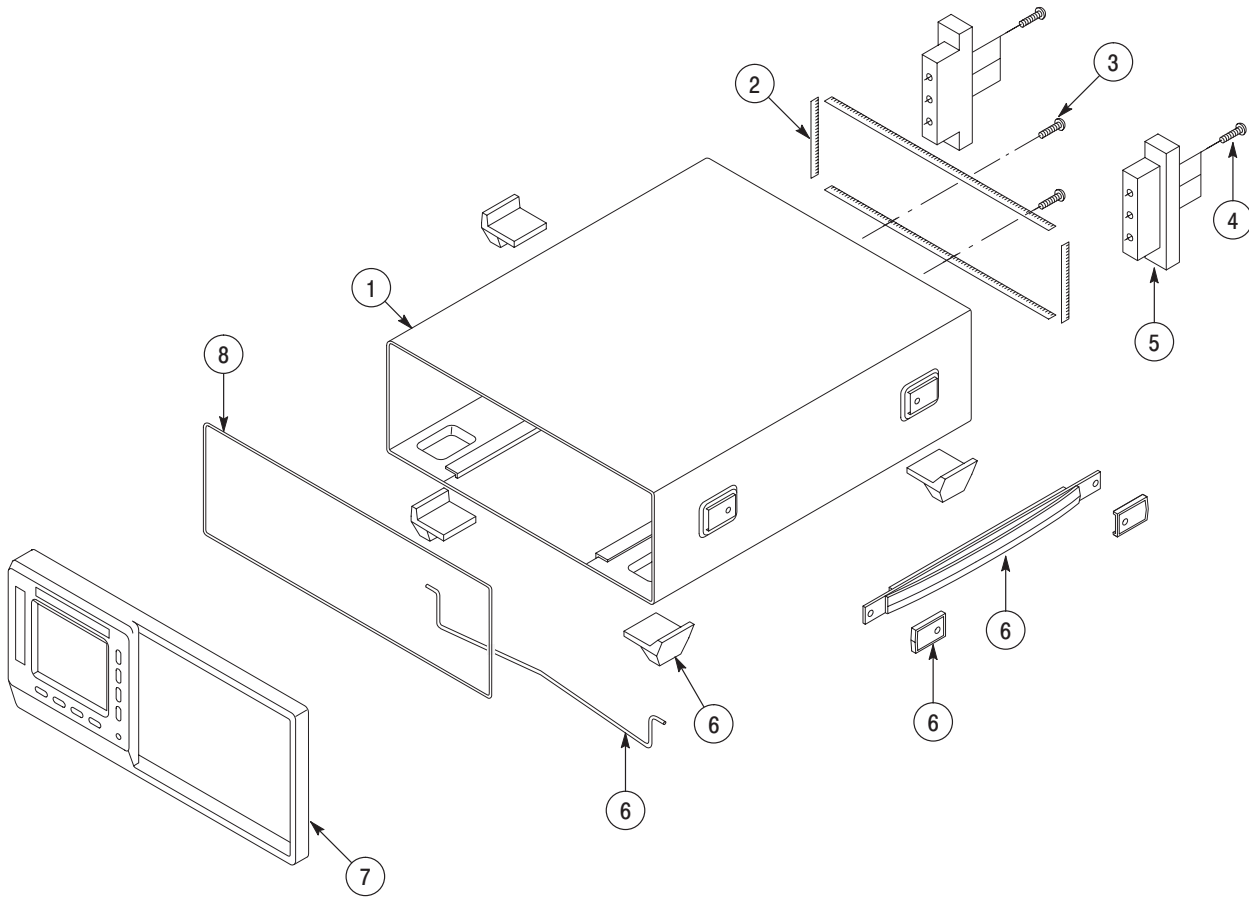

Figure 10-8: Cabinet

Replaceable Parts List

| Fig. & index number | Tektronix part number | Serial no. effective | Serial no. discont'd | Qty | Name & description | Mfr. code | Mfr. part number |
|---------------------|-----------------------|----------------------|----------------------|-----------|---|-----------|------------------|
| 10-9 | | | | | RACK MOUNT | | |
| -1 | 101-0142-01 | | | 1 | TRIM,DECORATIVE:FRONT,RACK MOUNT | | 101-0142-01 |
| -2 | 348-1569-00 | | | 114 CM | SHILD GASKET, ELEC:MESH TYPE, 3.2MM OD, SI SPONG CORE | | 348-1569-00 |
| -3 | 367-0022-00 | | | 2 | HANDLE,BOW:4.579 L,BRS CRPL | | 367-0022-00 |
| -4 | 212-0507-00 | | | 4 | SCREW,MACHINE:10-32 X 0.375,PNH,STL ZN-CM1,POZIDRIV | | 212-0507-00 |
| -5 | 390-A088-00 | | | 1 | CABINET ASSY:AL, AWG400 | | 390-A088-00 |
| -6 | 407-A651-01 | | | 2 | BRACKET: SUPPORT, SIDE, RACK MOUNT, AL | | 407-A651-00 |
| -7 | 211-0945-00 | | | 2 | SCREW, MACHINE:M4X8MM L,STL,ZN-C,CROSS REC | | 211-0945-00 |
| -8 | 348-1314-00 | | | 122 CM | GASKET,SHIELD:FINGER TYPE,BE-CU,609.6MM L,W/ADHESIVE | | 348-1314-00 |
| -9 | 212-0214-00 | | | 6 | SCREW,MACHINE:M5X12MM L,PNH,STL,ZN-C,CROSS REC,W/FLAT & LOCK WASHER | | 212-0214-00 |
| -10 | 351-0313-00 | | | 1 | GUIDE,RACKMOUNT:19.218 L,PAIR | | 351-0313-00 |
| -11 | 351-0623-00 | | | 1 | SLIDE,DWR,EXT:22.0 X 1.54,STEELSAFFTY CONTROLLED | | 351-0623-00 |
| -12 | 212-0507-00 | | | 4 | SCREW,MACHINE:10-32 X 0.375,PNH,STL ZN-CM1,POZIDRIV | | 212-0507-00 |
| -13 | 212-0215-00 | | | 4 | SCREW,MACHINE:M4X12MM L,PNH,STL,ZN-PL,CROSS REC,W/FLAT & LOCK WASHER | | 212-0215-00 |
| -14 | 407-4020-00 | | | 2 | BRACKET,SUPPORT:FRONT,ALUMINUM | | 407-4020-00 |

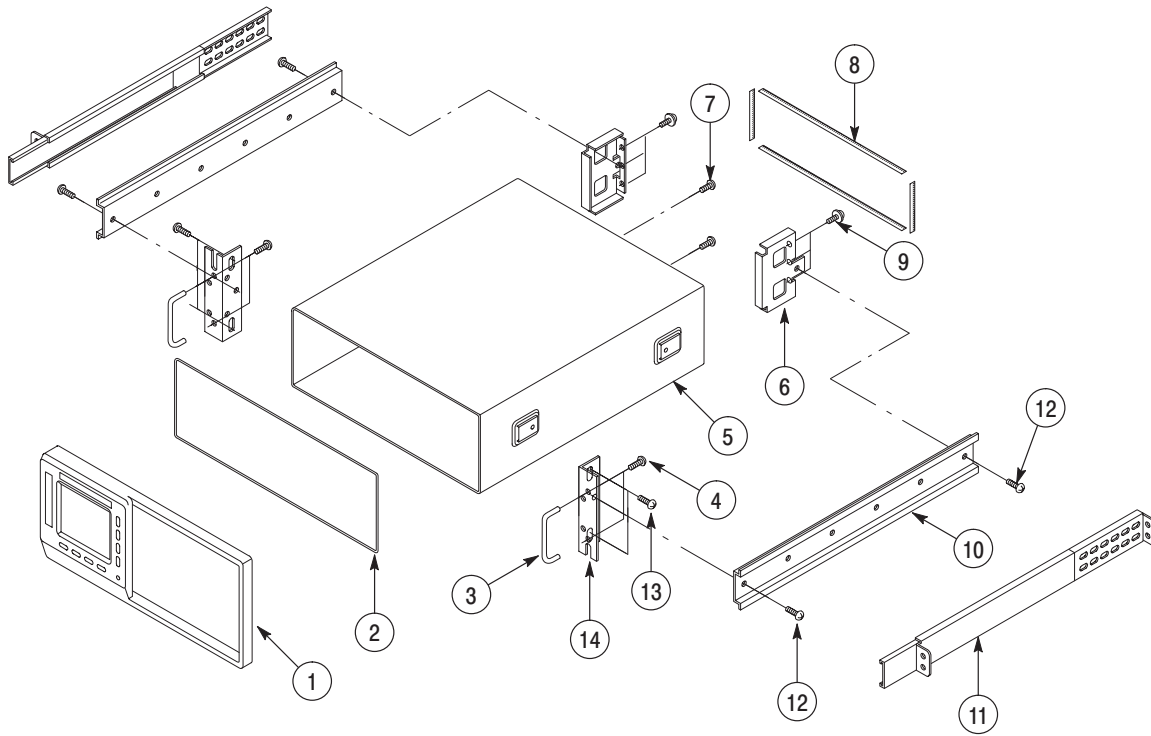

Figure 10-9: Rack mount

Replaceable Parts List

| Fig. & index number | Tektronix part number | Serial no. effective | Serial no. discont'd | Qty | Name & description | Mfr. code | Mfr. part number |
|---------------------|-----------------------|----------------------|----------------------|-----|--|-----------|------------------|
| 10-10 | 116-A015-01 | | | 1 | EXCHANGE MODULE:P4116 | | 116-A015-01 |
| -1 | 333-A426-00 | | | 1 | PANEL,FRONT:P4116,POLYCARBONATE | | 333-A426-00 |
| -2 | 441-A285-00 | | | 1 | CHASSIS,MAIN:P4116 | | 441-A285-00 |
| -3 | 211-A268-00 | | | 4 | SCREW,MACHINE:M3X6MML,FLH,STL,NI,CROSS REC | | 211-A268-00 |
| -4 | 390-A089-00 | | | 1 | CABINET:AL,P4116 | | 390-A089-00 |
| -5 | 333-A425-00 | | | 1 | PANEL,REAR:AL,P4116 | | 333-A425-00 |

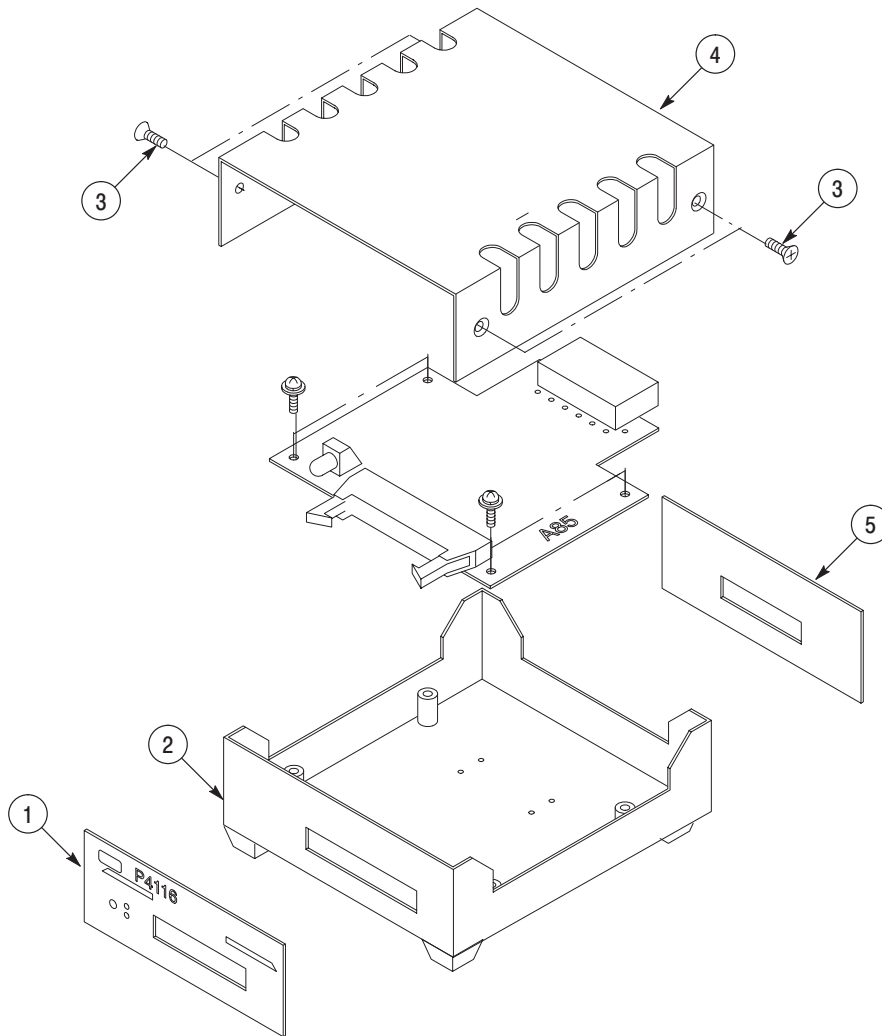

Figure 10-10: P4116